



PRODUCT CATALOG

**PLASMA
MIG/TIG
ACCESSORIES**

A PROGRESSIVE COMPANY FOR AN EVOLVING MARKET

Over a period of 25 years the Thermacut Group has undergone a multitude of changes. Thermacut (originally Tatra Imports Inc.) was incorporated in Claremont, New Hampshire in 1990 and sold under the brand ZAP Plasmatherm, a reseller of plasma consumables from local vendors directly to end-users. The company began operating with three employees, conducting business through telephone sales. In 1992, the company opened a small manufacturing facility and a sales office in the Czech Republic in 1996 to produce and sell plasma consumables and torches directly into the Eastern European market and through distributors in Western Europe under the brand name Thermacut utilizing both inside and outside sales representatives. And in 1993 the Thermacut brand was introduced into North America and sold through distributors.

In January of 1999 STK Gesellschaft für Schweißtechnik GmbH (a holding company 100% owned by the IBG Group of Cologne Germany) purchased 80% of the shares of Thermacut and in 2002 completed the acquisition to become the 100% shareholder of the Thermacut Group.

Since those early and humble beginnings, Thermacut has evolved into a major force in providing plasma torches and consumables through multiple sales channels supported by fourteen sales subsidiaries and with a close partnership with Abicor-Binzel (an IBG owned company) with locations in India, the Middle East, Turkey, Belarus, Denmark, Norway, Sweden, Finland, United Kingdom, Japan, South Korea, Vietnam and Australia. Based on customer demand Thermacut has also introduced TIG/WIG, MIG/MAG and Oxy-fuel products and produces those products at its modern ISO 9001 production facility located in Uherske Hradiste of the Czech Republic.

The Thermacut Group has focused its efforts in providing high quality direct replacement consumable and torch product lines that will meet or exceed the expectations of our valued customers, cutting and welding metals thermally throughout the world. But as our customer base expanded,

their expectations and demands also increased, where in 2005 Thermacut expanded its product portfolio with the addition of advanced consumables, which have included products such as the Silver Plus™, Silver Pro™ and SilverEX-® electrodes, plus the patented TungstenEX-™ nozzles. At that time to signify our advanced products offerings we also updated our corporate image, introducing a new logo, a new orange and black color scheme, and a new slogan: "Advanced Consumables" and a mission to be the Providers of Advanced Cutting and Welding Consumables Worldwide.

By 2013, the Thermacut Group continued to expand and evolve in the thermal cutting and welding marketplace. In December of 2012 the Thermacut Group concluded the purchase of the HOLMA® AG, a producer of premium quality laser consumables, which enhances our customer's ongoing requests for a high quality laser consumable brand and a further expansion of Thermacut's plasma cutting and oxy-fuel consumable product portfolio.

In September 2013 at the SCHWEISSEN & SCHNEIDEN Exposition, the Thermacut Group evolved once again with the introduction of a line of plasma cutting systems for both manual and mechanized plasma processes up to 65 mm thickness. The initial introduction will feature a 105 amp system. Thermacut also had the 65 and 85 amp systems on display.

During 2015 the line of plasma systems will be rolled out on a planned basis, which will range from 30 amps to 125 amps. This change will mark a major commitment to our valued customers throughout the world and thrust Thermacut into the ranks of a full line plasma OEM.

Recognizing this continuing evolution is important, so the Thermacut Group has updated its logo, change its' slogan to "The Cutting Company" and further its mission by becoming a "Global Provider of Thermal Cutting Technology".



CUSTOMER SERVICE DEPARTMENT:

TEL. (800) 932-8312 OR (603) 542-6715
FAX (800) 972-6255 OR (603) 542-2867
E-MAIL: SALES@THERMACUT.COM

SHIPPING:

SAME-DAY (ORDERS PLACED BY 3:00 PM E.S.T.)
MINIMUM ORDER: \$50.00

FREIGHT POLICY, CONTINENTAL USA:

ORDERS OVER \$500 SHIP FREE VIA UPS GROUND OR TRUCK SERVICE (OUR CHOICE).
BACK ORDERS WILL BE SHIPPED FREE VIA UPS GROUND OR AIR FOR TWO (2) DAY DELIVERY (OUR CHOICE).

FREIGHT POLICY, HAWAII, ALASKA, PUERTO RICO:

CUSTOMER PAYS ALL FREIGHT CHARGES.

FREIGHT POLICY, CANADA:

ORDERS OVER \$500 SHIP FREE VIA UPS CANADA STANDARD OR TRUCK SERVICE (OUR CHOICE). BACK ORDERS WILL BE SHIPPED VIA FREE UPS GROUND OR AIR FOR TWO (2) DAY DELIVERY (OUR CHOICE). ALL OTHER ORDERS OR SHIPPING METHODS THE CUSTOMER PAYS ALL FREIGHT CHARGES.

RETURNS:

RETURN GOODS AUTHORIZATION (RGA) REQUIRED. SPECIAL ORDER, OEM ITEMS, OR PURCHASES OVER 1-YEAR OLD ARE NON-RETURNABLE. RETURNS MUST BE IN ORIGINAL PACKAGING WITH LEGIBLE LOT NUMBERS; RETURNED TORCHES MUST HAVE USED CONSUMABLES "IN-PLACE" (SEE WARRANTY SECTION). CREDITS MUST BE USED WITHIN 90 DAYS OF ISSUANCE.

APPROVALS/PAYMENT METHODS:

FAST CREDIT APPROVAL NET-30 TERMS, C.O.D, VISA, MASTER CARD, AMERICAN EXPRESS, DISCOVER. OVERDUE ACCOUNTS ARE SUBJECT TO CREDIT HOLD.

TECHNICAL SUPPORT:

CONTACT CUSTOMER SERVICE DEPARTMENT

PRICING:

PRICES SUBJECT TO CHANGE WITHOUT NOTICE. QUOTES GOOD FOR 30 DAYS.

TERMS & CONDITIONS:

THERMACUT, INC. OFFERS TO SELL PRODUCTS TO YOU UNDER OUR STANDARD TERMS AND CONDITIONS. OUR STANDARD TERMS AND CONDITIONS CAN BE VIEWED ON OUR WEBSITE WWW.THERMACUT.COM, OR YOU CAN CALL (603) 542-6715 AND REQUEST THAT THEY BE MAILED TO YOU. WE OBJECT TO ANY DIFFERENT OR ADDITIONAL TERMS.

LIMITED WARRANTY

Statement of Limited Warranty: Subject to the terms and conditions below, Thermacut, Inc., Claremont, New Hampshire, (Seller) warrants to the original Buyer that its new Thermacut products sold after the effective date of this limited warranty, April 24, 2005 will be free of defects in materials and workmanship at the time it is shipped by Seller. For purposes of this warranty, a defective item is an item that is found by Seller to have been defective in materials or workmanship, if the defect materially impairs the value of the goods to Buyer. If Buyer shall have approved a sample or drawing of, or specifications for, the goods, then the goods shall not be defective to the extent they conform to the sample, drawings, or specifications

Limitation of Liability: Seller's liability under this warranty shall be limited at its sole option to repairing or replacing any defective goods at Seller's factory or issuing a credit to Buyer for the purchase price of the defective goods. In any case, Seller shall have no liability under this warranty except for goods returned to Seller's factory, freight prepaid, and with a valid Returned Goods Authorization number within the warranty period (see below) after delivery of the goods to Buyer. If Buyer does not return the defective goods to Seller within the warranty period after the delivery of the goods to the Buyer, any claim for breach of warranty shall be conclusively deemed to have been waived and Seller shall not be liable under this warranty. Seller's acceptance of any goods returned shall not be deemed an admission that the goods are defective, or in breach of any warranty, and if Seller determines that the goods are not defective based on Seller's accepted method of testing, the goods shall be reshipped to Buyer at Buyer's expense. All parts returned and retained by Seller shall become Seller's property. Seller will not accept or be liable for back charges for labor or repair costs incurred by Buyer without the prior written consent of Seller. This warranty shall not apply to any goods that have been altered or repaired, or that have been subject to misuse, negligence or accident, including, without limitation, use and operation of the goods while any parts are loose, broken or damaged or have been used with parts other than original Seller parts, which may affect performance or safety. Seller's liability for any defect in the goods shall not exceed the purchase price of the goods

THE WARRANTIES HEREIN ARE IN LIEU OF ALL WARRANTIES, EXPRESS, IMPLIED, STATUTORY OR OTHERWISE. IN PARTICULAR, SELLER MAKES NO WARRANTY OF MERCHANTABILITY OR FITNESS FOR A PARTICULAR PURPOSE. Seller shall not be liable for incidental or consequential damages arising from any product defect, delay, recall, non-delivery or other breach. Seller shall not be liable to Buyer in tort, including, but not limited to any claim for negligent manufacture of the goods or for the omission of any warning there-from.

No employee, representative, agent or distributor of Seller except the President of Seller has authority to modify, expand or extend this warranty, to waive any of the limitations or exclusions, or to make any different or additional warranties with respect to the goods. On any resale of the goods, Buyer shall contractually limit its customer's rights and remedies against both Buyer and Seller to the same extent as Buyer's rights and remedies are limited under this warranty. Notwithstanding any other provision in this agreement, Seller shall not be liable to a customer of Buyer for any modification, extension or expansion of this warranty by Buyer beyond the scope of this warranty or for any different or additional warranties made by Buyer with respect to the goods.

Plasma Torches with or without leads	1 Year
Plasma Torch Replacement Parts	90 Days
Plasma Consumable Components *	Defect only
Laser Replacement Parts	90 Days
Oxy-Fuel Replacement Parts.....	90 Days
TIG Torches with or without leads	90 Days
TIG Torch Replacement Parts	90 Days
TIG Consumable Components *	Defect only
MIG Torches and Leads	90 Days
MIG Torch Replacement Parts	90 Days
MIG Consumable Components *	Defect only
OEM Torches and leads	No Warranty Allowed
OEM consumable components	No Warranty Allowed

*Thermacut is not responsible for the replacement of any consumable components due to normal wear.

Obligations of the User: These products will perform in accordance to the manufacturers or OEM requirements when installed, operated, maintained and repaired as recommended. Parts that are broken, missing, worn, distorted or contaminated should be repaired immediately. Should such a repair or replacement become necessary Thermacut recommends that a request be made to an Authorized Distributor from whom the product was purchased. Torches returned to Thermacut for warranty due to the failure to conform must be accompanied by the torch parts used at the time of non-conformance. Failure to comply will void the warranty.

TABLE OF CONTENTS

PLASMA

THERMACUT® REPLACEMENT PARTS SUITABLE FOR AJAN®

TORCH	PAGE
HP260A™ mild steel	11
HP260A™ stainless steel	12-13
HP260A™ aluminium	14-15

THERMACUT® REPLACEMENT PARTS SUITABLE FOR ESAB®/L-TEC®

TORCH	PAGE
PT-15™/PT-15XL™	16-17
PT-15™/PT-15XL™ TORCH	18-19
PT-19XL™/PT-19XL™	20-21
PT-23™	22
PT-24™	23
PT-27™	24-25
PT-31™/PT-31XL™	26
PT-36™	28-29
PT-600™	30-31

THERMACUT® REPLACEMENT PARTS SUITABLE FOR Hypertherm®

TORCH	SYSTEM	PAGE
PAC®120/125T	MAX®40cs/MAX®42/MAX®43	32
PAC®140/M	MAX®40	33
PAC®140/M	HT®40	34
PAC®130/M	MAX®70/MAX®80/MAX®100	35
PAC®123T/M	POWERMAX® 600	36-37
PAC®121T/M / PAC®125T/M	POWERMAX® 800	38-39
PAC®125T/M	POWERMAX® 900	40-41
T60™/T60M™,T80™/T80M™, T100™/T100M™	POWERMAX® 1000 / POWERMAX® 1250 / POWERMAX® 1650	42-43
T60™/T60M™ torch, T80™/T80M™ torch, T100™/T100M™ torch	POWERMAX® 1000 / POWERMAX® 1250 / POWERMAX® 1650	44-45
T60M™/T80M™ machine torch, T60™/T80™ hand torch	POWERMAX® 1000, POWERMAX® 1250	46
T100™/T100M™ machine/hand	POWERMAX® 1650	47
DURAMAX® hand torch, DURAMAX® machine torch	POWERMAX® 1000 / POWERMAX® 1250 / POWERMAX® 1650	48-49
T30v™ hand torch	POWERMAX® 30 XP, AIR	50
T30v™/T45v™ hand torch, T45m™ machine torch	POWERMAX® 45	51

THERMACUT®, FHT-EX® AND EX-TRAFIRE® ARE REGISTERED TRADEMARKS OF THERMACUT, K. S. AND MAY BE REGISTERED IN CZECH REPUBLIC AND/OR OTHER COUNTRIES. ALL OTHER TRADEMARKS ARE PROPERTIES OF THEIR RESPECTIVE OWNERS. THERMACUT IS IN NO WAY AFFILIATED WITH AJAN®, ESAB®/L-TEC®, HYPERTHERM®.

TABLE OF CONTENTS

PLASMA

REPLACEMENT PARTS SUITABLE FOR HYPER THERM®

TORCH	SYSTEM	PAGE
DURAMAX® hand torch, DURAMAX® machine torch	POWERMAX® 45XP	52
DURAMAX® hand torch, DURAMAX® machine torch	POWERMAX® 65 / POWERMAX® 85 / POWERMAX® 105	54-57
DURAMAX® HYAMP™	POWERMAX® 125	58
DURAMAX® HYAMP™ TORCHES AND CABLE LEADS	POWERMAX® 125	59
PAC®200/T	HT®2000 HySpeed®	60-61
For HT®2000 ms, ss, al	HyPro™2000/MaxPro™200 upgrade torch	62-63
PAC®200T/E	MAX®200	64-65
For MAX®200 ms, ss, al	HyPro™2000/MaxPro™200 upgrade torch	66-67
HT®400, PAC®170/PAC®600, PAC®620 with slave, PAC®620 without slave	HT®400, HT®4000, HT®4001	68-69
MODEL 500®	PAC®500	70
PAC®182/186/190	HD®1070/HD®3070 HyDefinition®	71
HPR®130/HPR®260 ms	HPR®130/HPR®260	72-73
HPR®130/HPR®260 ss	HPR®130/HPR®260	74-75
HPR®130/HPR®260 al	HPR®130/HPR®260	76-77
Torches and Cable leads	HPR®130/HPR®260	78-79
HPR®130XD/HPR®260XD/HPR®400XD ms	HPR®130XD/HPR®260XD/HPR®400XD	80-81
HPR®130XD/HPR®260XD/HPR®400XD ss	HPR®130XD/HPR®260XD/HPR®400XD	82-83
HPR®130XD/HPR®260XD/HPR®400XD al	HPR®130XD/HPR®260XD/HPR®400XD	84-85
Torches and Cable leads	HPR®130XD/HPR®260XD/HPR®400XD	86-87
HSD®130 ms	HySpeed® Plasma	88
HSD®130 ss	HySpeed® Plasma	89
HSD®130 al	HySpeed® Plasma	90
XPR®170/300	HyPerformance® Plasma	91

REPLACEMENT PARTS SUITABLE FOR KALIBURN®

TORCH	SYSTEM	PAGE
SPIRIT® 150a, 200a, 275a, 400a, ProLine™ 2150, 2200, 2260 ms	SPIRIT®, ProLine™	92-93
SPIRIT® 150a, 200a, 275a, 400a, ProLine™ 2150, 2200, 2260 ss	SPIRIT®, ProLine™	94-95
SPIRIT® 150a, 200a, 275a, 400a, ProLine™ 2150, 2200, 2260 al	SPIRIT®, ProLine™	96-97
TORCHES	SPIRIT®, ProLine™	98

THERMACUT®, FHT-EX® AND EX-TRAFIRE® ARE REGISTERED TRADEMARKS OF THERMACUT, K. S. AND MAY BE REGISTERED IN CZECH REPUBLIC AND/OR OTHER COUNTRIES. ALL OTHER TRADEMARKS ARE PROPERTIES OF THEIR RESPECTIVE OWNERS. THERMACUT IS IN NO WAY AFFILIATED WITH HYPER THERM®, KALIBURN®.

TABLE OF CONTENTS

PLASMA

REPLACEMENT PARTS SUITABLE FOR KJELLBERG®

TORCH	SYSTEM	PAGE
PB-S45W™	PA-S20W™, PA-S25W™, PA-S40W™, PA-S45W™, PA-S70W™	100-101
PB-S47™	FineFocus® 450	102-103
PerCut® 100, PerCut® 101	HiFocus® 100	104-105
PerCut® 160 / PerCut® 170	HiFocus® 160i	106-107
PerCut® 160 / PerCut® 170 TORCHES AND CABLE LEADS	HiFocus® 160i	108-109
PerCut® 200 / 201 / 210 / 211 / 450M / 451M ms	HiFocus® 160i, HiFocus® 280i, HiFocus® 360i, HiFocus® 440i	110-111
PerCut® 200 / 201 / 210 / 211 / 450M / 451M ss	HiFocus® 160i, HiFocus® 280i, HiFocus® 360i, HiFocus® 440i	112-113
PerCut® 370.1, PerCut® 370.2	HiFocus® 280 / HiFocus® 360, HiFocus® 440	114-115
PA-S75™/PB-S75™/PB-S76™/PB-S77™	FineFocus® 800 / FineFocus® 900	116
PB-S80™	FineFocus® 800 / FineFocus® 900	117

REPLACEMENT PARTS SUITABLE FOR KOMATSU®

TORCH	SYSTEM	PAGE
RASOR® KCR-1251, 12714, 9714, 0951	G990™, G9120™ TORCH, 90A	118

REPLACEMENT PARTS SUITABLE FOR LINCOLN ELECTRIC®

LINCOLN ELECTRIC® TORCH	POWER SUPPLY	PAGE
APPLICATION OF DURAMAX® TORCH TO TOMAHAWK® 1538 CUTTING SYSTEM	LINCOLN ELECTRIC® TH1538	119
PCT-20/PCT-80	Pro-Cut® 25, Pro-Cut® 55, Pro-Cut® 80	120

REPLACEMENT PARTS SUITABLE FOR THERMAL DYNAMICS®

TORCH	POWER SUPPLY	PAGE
PCH/M 10/25/38	Drag-Gun®, PakMaster™25, EconoPak™25	121
PCH/M 28/PCH-26	PakMaster™50XL, PakMaster™50XL Plus, EconoPak™50	121
PCH/M 35/40	StakPak™35, PakMaster™50	121
PCH/M 75, 76	PakMaster™75/75XL PLUS, 100XL PLUS, EconoPak™100, Cutmaster™80XL™	122
PCH42/62/102/1Torch®	(various)	123
PCH/M 51	PAK® 3XR™, 5XR™, 5XT™, 6XR™, 625XR™, 750XR™, Dynapak 4Xi™, 6Xi™	124
PCH/M 52	PAK® 5XR™, 6XR™, 7XR™, 8XR™, 10XR™, 625XR™, 750XR™, 1000XR™, 1250XR™	124
PCH/M 150	MERLIN™15XC	124
PCH/M-6B	PAK® 44,45	125-126
MAXIMIZER™300/ MERLIN™6000/ MERLIN™6000GST	MERLIN™1000/3000/6000, PAK®15XC	127

THERMACUT®, FHT-EX® AND EX-TRAFIRE® ARE REGISTERED TRADEMARKS OF THERMACUT, K. S. AND MAY BE REGISTERED IN CZECH REPUBLIC AND/OR OTHER COUNTRIES. ALL OTHER TRADEMARKS ARE PROPERTIES OF THEIR RESPECTIVE OWNERS. THERMACUT IS IN NO WAY AFFILIATED WITH KJELLBERG®, KOMATSU®, LINCOLN ELECTRIC®, Thermal Dynamics®.

TABLE OF CONTENTS

PLASMA

REPLACEMENT PARTS SUITABLE FOR THERMAL DYNAMICS®

TORCH	SYSTEM	PAGE
PCH/M 120	PakMaster™150XL	127
PWH/M 2A / PWH/M 3A / PWH/M 4A	ULTIMA™150	128-131
PWM 300	ULTIMA™150	132

ACCESSORIES

MANUFACTURER - THERMACUT®	PAGE
Coolant Liquid	134
Anti-Spatter Spray	134
Plasma Table Fluid	134
Electrical Conductivity Meter	135
Electrode Pit-Depth Gauge	135
Filter-EX	136
Heat Shield Grease	136
Silicone Lubricant	137
Safety Glass Shield	137
THERMACUT® consumable case suitable for Hypertherm® HPR®130/HPR®260	138
THERMACUT® consumable case suitable for Hypertherm® HPR®130XD/HPR®260XD	139
THERMACUT® consumable case suitable for ESAB® PT-36™	140
THERMACUT® consumable case suitable for Hypertherm® POWERMAX® 65 / POWERMAX® 85 / POWERMAX® 105	141
Definitions of Suffixes, Symbols & Abbreviations	142

TABLE OF CONTENTS

MIG-TIG WELDING

REPLACEMENT PARTS SUITABLE FOR:

MIG SYSTEM	PAGE
BERNARD®	144-147
MILLER®	148-151
TREGASKISS®	152-155
TWECO®	156-161
Back-end Plugs and Connectors	162-163

TIG SYSTEM	PAGE
TUNGSTENS	164
TORCHES 9, 20, 24, 25	165-166
TORCHES 17, 18, 26	167-168
BACK CAPS, INSULATORS, COLLETS, COLLET BODIES, GAS LENSES, POWER CABLE ADAPTERS, ALUMINA CUPS	169-171

A grayscale photograph of a worker in a factory setting. The worker is wearing safety glasses and large earplugs, looking towards the camera. In the foreground, a plasma cutting torch is positioned vertically, cutting through a metal plate. A bright, intense light is visible at the point of contact between the torch and the metal, with a spray of sparks radiating outwards. The background shows industrial machinery and a clean, well-lit environment.

PLASMA CUTTING

**THERMACUT® REPLACEMENT PARTS SUITABLE FOR
AJAN®
HP260A™ MILD STEEL**

PRODUCT BROCHURE WITH DETAILS AT
WWW.THERMACUT.COM

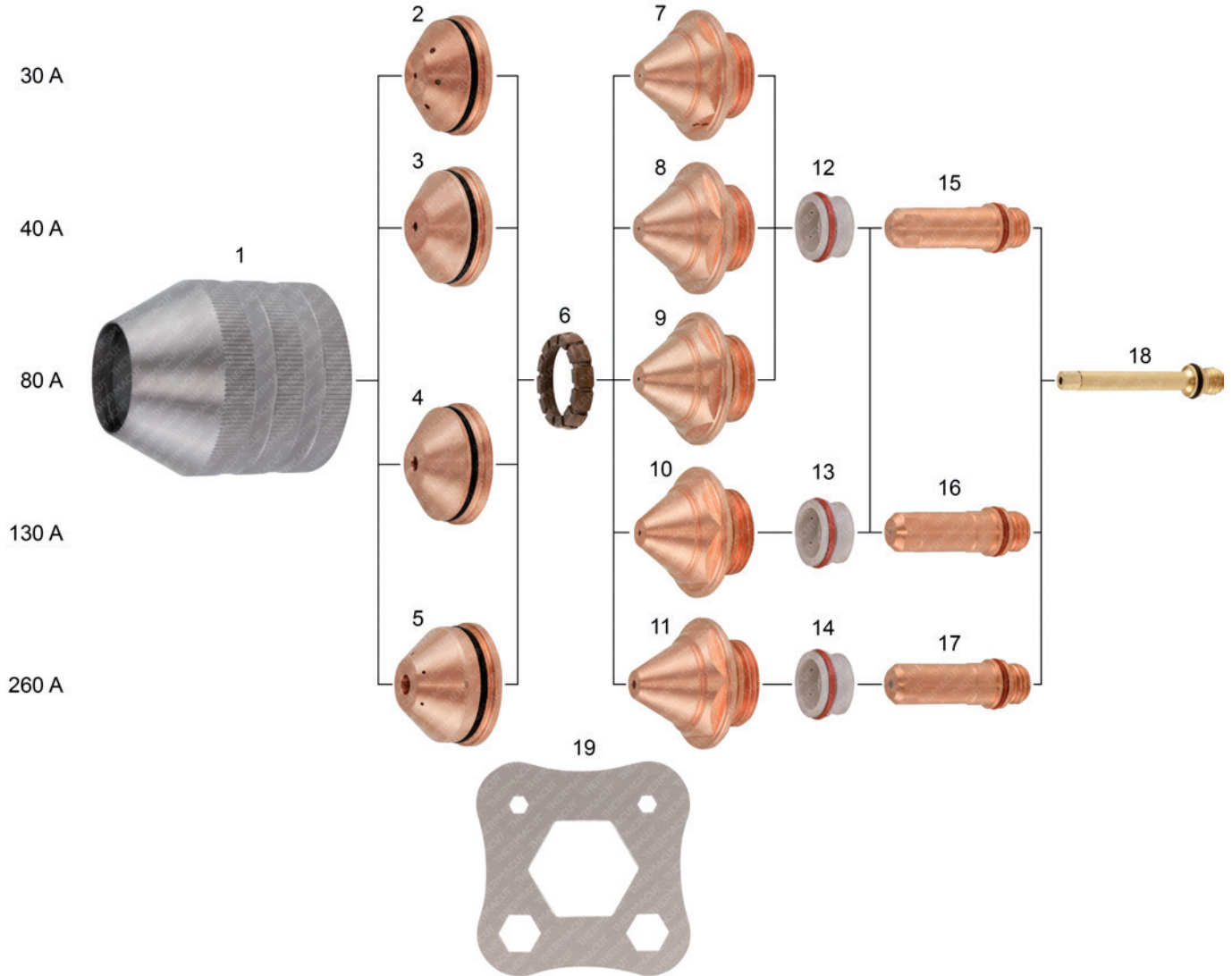

Item	Part No.	Ref. No.	Description	Std. Pkg.	Item	Part No.	Ref. No.	Description	Std. Pkg.
1.	T-11408	SC2-UR	Shield Cap 30-260A	1	11.	T-11333	N7	Nozzle 260A	1
2.	T-11334	S1	Shield 30A	10		T-12264	N8	Nozzle 260A SS, AL, Air	1
3.	T-11335	S2	Shield 40A	10		T-12265	N9	Nozzle 260A SS, AL, H35/N ₂	1
4.	T-11336	S3	Shield 80/130A	10	*12.	T-11338*	SW1-UR	Swirl Ring 30-80A	1
5.	T-11337	S4	Shield 260A	5	*13.	T-11339*	SW2-UR	Swirl Ring 130A	1
6.	T-11328	G1	Gas Ring 30-260A	2	*14.	T-11340*	SW3-UR	Swirl Ring 260A	1
7.	T-11329	N1	Nozzle 30A	1	15.	T-11341	E0	Electrode 30-80A	5
8.	T-11330	N2	Nozzle 40A	1	16.	T-11342	E1	Electrode 130A	5
9.	T-11331	N3	Nozzle 80A	1	17.	T-11343	E3	Electrode 260A	5
					18.	T-11327	B1	Cooling Tube	1
10.	T-11332	N5	Nozzle 130A	1	*19.	T-11351*	100-07-106535-UR	Consumable Removal Tool	1
	T-12262	N4	Nozzle 80A SS	1					
	T-12263	N6	Nozzle 130A SS	1					

* FULLY INTERCHANGEABLE AND COMPATIBLE WITH ORIGINAL PARTS, BUT DIFFERS FROM ORIGINAL DESIGN

THERMACUT®, FHT-EX® AND EX-TRAFIRE® ARE REGISTERED TRADEMARKS OF THERMACUT, K. S. AND MAY BE REGISTERED IN CZECH REPUBLIC AND/OR OTHER COUNTRIES. ALL OTHER TRADEMARKS ARE PROPERTIES OF THEIR RESPECTIVE OWNERS. THERMACUT IS NO WAY AFFILIATED WITH AJAN®. MOST THERMACUT PARTS ARE MADE FOR OR BY AN IBG COMPANY. PARTS INDICATED WITH A OEM ARE ORIGINAL PARTS MANUFACTURED BY THE ABOVE NAMED MANUFACTURER AND ARE BEING RESOLD BY THERMACUT. THERMACUT RESERVES THE RIGHT TO SUBSTITUTE OEM PARTS IN PLACE OF THERMACUT PARTS. VALID FROM SEPTEMBER 2024 • PREVIOUS VERSION IS NO LONGER VALID. • © COPYRIGHT 2024 BY THERMACUT® CZECH REPUBLIC. ALL RIGHTS RESERVED.

**THERMACUT® REPLACEMENT PARTS SUITABLE FOR
AJAN®
HP260A™ STAINLESS STEEL**

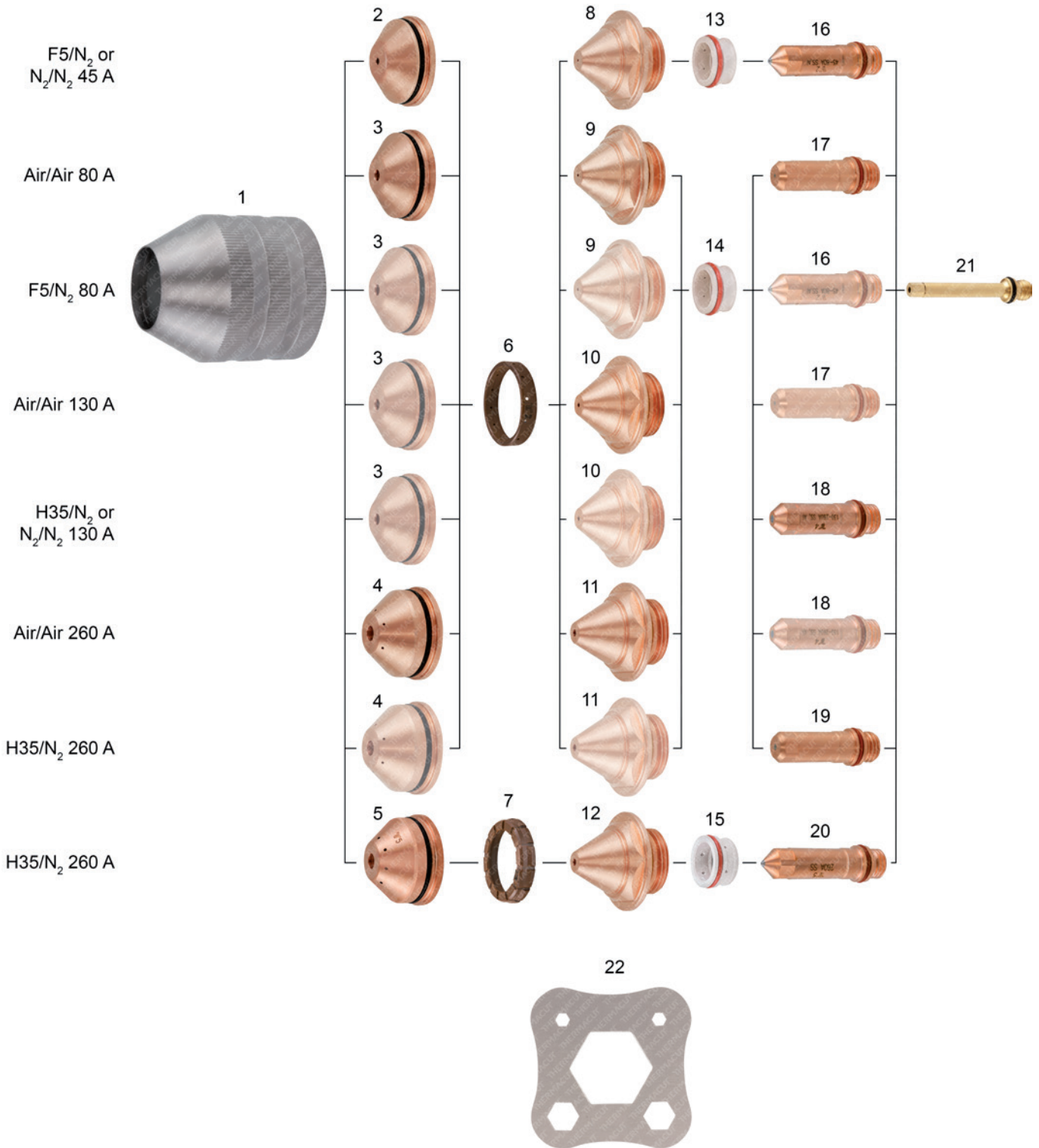

THERMACUT®, FHT-EX® AND EX-TRAFIRE® ARE REGISTERED TRADEMARKS OF THERMACUT, K. S. AND MAY BE REGISTERED IN CZECH REPUBLIC AND/OR OTHER COUNTRIES. ALL OTHER TRADEMARKS ARE PROPERTIES OF THEIR RESPECTIVE OWNERS. THERMACUT IS NO WAY AFFILIATED WITH AJAN®. MOST THERMACUT PARTS ARE MADE FOR OR BY AN IBG COMPANY. PARTS INDICATED WITH A OEM ARE ORIGINAL PARTS MANUFACTURED BY THE ABOVE NAMED MANUFACTURER AND ARE BEING RESOLD BY THERMACUT. THERMACUT RESERVES THE RIGHT TO SUBSTITUTE OEM PARTS IN PLACE OF THERMACUT PARTS. VALID FROM SEPTEMBER 2024 • PREVIOUS VERSION IS NO LONGER VALID. • © COPYRIGHT 2024 BY THERMACUT® CZECH REPUBLIC. ALL RIGHTS RESERVED.

**THERMACUT® REPLACEMENT PARTS SUITABLE FOR
AJAN®
HP260A™ STAINLESS STEEL**

Item	Part No.	Ref. No.	Description	Std. Pkg.	Item	Part No.	Ref. No.	Description	Std. Pkg.
1.	T-11408	SC2-UR	Shield Cap 30-260A	1	*13.	T-11338*	SW1-UR	Swirl Ring 30-80A	1
2.	T-11335	S2	Shield 40A	10	*14.	T-11339*	SW2-UR	Swirl Ring 130A	1
3.	T-11336	S3	Shield 80/130A	10	*15.	T-13144*	SW4-UR	Swirl Ring 260A SS 50mm+	1
4.	T-11337	S4	Shield 260A	10	16.	T-13138	E2	Electrode 45-80A, F5-N ₂	5
5.	T-13143	S5	Shield 260A SS, AL	10	17.	T-11342	E1	Electrode 130A	5
6.	T-13141	G2	Gas Ring 45-80A 130-260A SS, AL	1	18.	T-13139	E4	Electrode 130A-260A, H35-N ₂	5
7.	T-13142	G3	Gas Ring 260A SS	1	19.	T-11343	E3	Electrode 260A	5
8.	T-11330	N2	Nozzle 40A	1	20.	T-13140	E5	Electrode 260A SS 50mm+	5
9.	T-12262	N4	Nozzle 80A SS	1	21.	T-11327	B1	Cooling Tube	1
10.	T-12263	N6	Nozzle 130A SS	1	*22.	T-11351*	100-07-106535-UR	Consumable Removal Tool	1
11.	T-12264	N8	Nozzle 260A SS, AL, Air	1					
12.	T-12265	N9	Nozzle 260A SS, AL, H35/N ₂	1					

* FULLY INTERCHANGEABLE AND COMPATIBLE WITH ORIGINAL PARTS, BUT DIFFERS FROM ORIGINAL DESIGN

THERMACUT®, FHT-EX® AND EX-TRAFIRE® ARE REGISTERED TRADEMARKS OF THERMACUT, K. S. AND MAY BE REGISTERED IN CZECH REPUBLIC AND/OR OTHER COUNTRIES. ALL OTHER TRADEMARKS ARE PROPERTIES OF THEIR RESPECTIVE OWNERS. THERMACUT IS NO WAY AFFILIATED WITH AJAN®. MOST THERMACUT PARTS ARE MADE FOR OR BY AN IBG COMPANY. PARTS INDICATED WITH A OEM ARE ORIGINAL PARTS MANUFACTURED BY THE ABOVE NAMED MANUFACTURER AND ARE BEING RESOLD BY THERMACUT. THERMACUT RESERVES THE RIGHT TO SUBSTITUTE OEM PARTS IN PLACE OF THERMACUT PARTS. VALID FROM SEPTEMBER 2024 • PREVIOUS VERSION IS NO LONGER VALID. • © COPYRIGHT 2024 BY THERMACUT® CZECH REPUBLIC. ALL RIGHTS RESERVED.

**THERMACUT® REPLACEMENT PARTS SUITABLE FOR
AJAN®
HP260A™ ALUMINIUM**

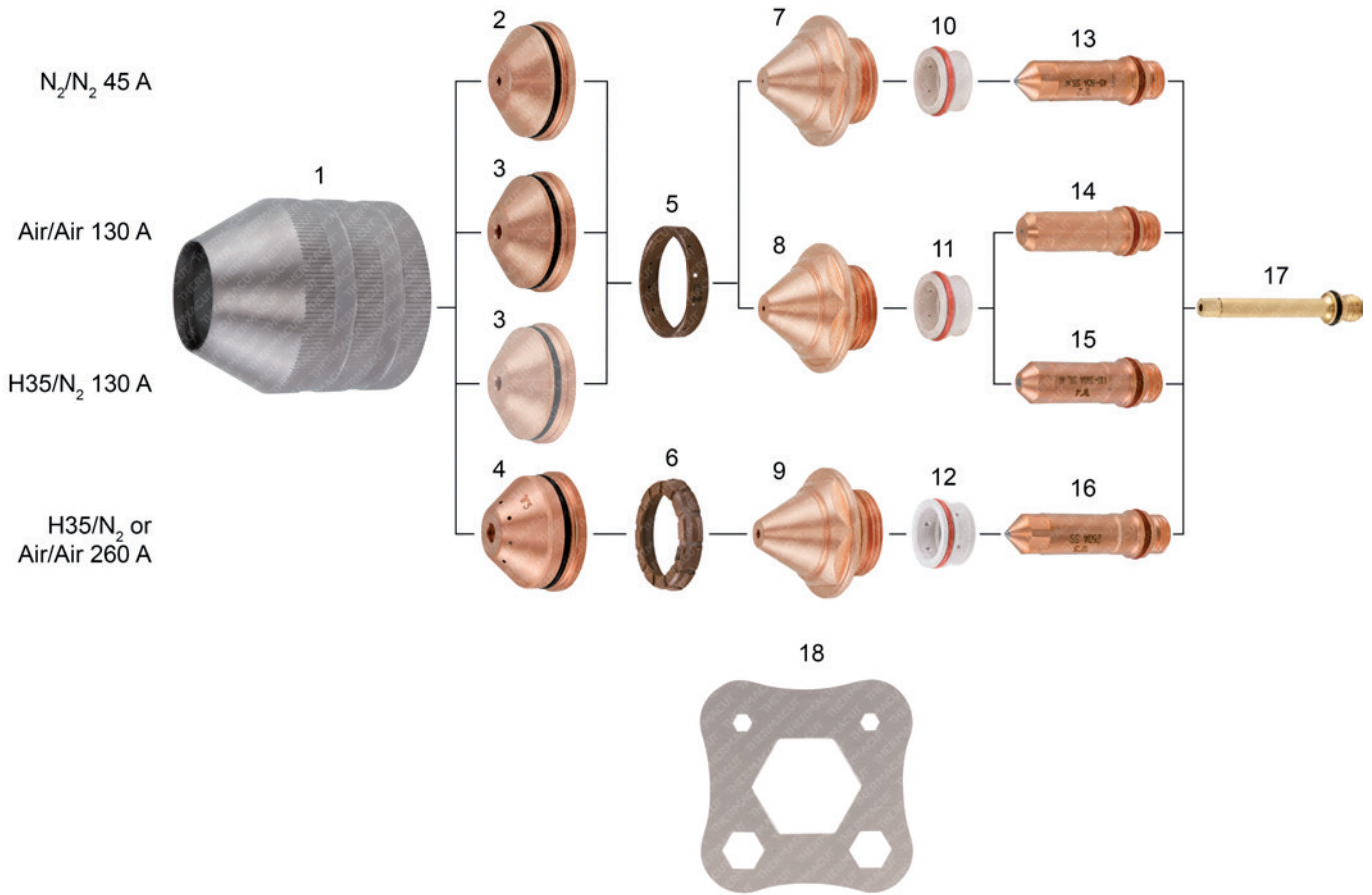

THERMACUT®, FHT-EX® AND EX-TRAFIRE® ARE REGISTERED TRADEMARKS OF THERMACUT, K. S. AND MAY BE REGISTERED IN CZECH REPUBLIC AND/OR OTHER COUNTRIES. ALL OTHER TRADEMARKS ARE PROPERTIES OF THEIR RESPECTIVE OWNERS. THERMACUT IS NO WAY AFFILIATED WITH AJAN®. MOST THERMACUT PARTS ARE MADE FOR OR BY AN IBG COMPANY. PARTS INDICATED WITH A OEM ARE ORIGINAL PARTS MANUFACTURED BY THE ABOVE NAMED MANUFACTURER AND ARE BEING RESOLD BY THERMACUT. THERMACUT RESERVES THE RIGHT TO SUBSTITUTE OEM PARTS IN PLACE OF THERMACUT PARTS. VALID FROM SEPTEMBER 2024 • PREVIOUS VERSION IS NO LONGER VALID. • © COPYRIGHT 2024 BY THERMACUT® CZECH REPUBLIC. ALL RIGHTS RESERVED.

**THERMACUT® REPLACEMENT PARTS SUITABLE FOR
AJAN®
HP260A™ ALUMINIUM**

Item	Part No.	Ref. No.	Description	Std. Pkg.	Item	Part No.	Ref. No.	Description	Std. Pkg.
1.	T-11408	SC2-UR	Shield Cap 30-260A	1	*11.	T-11339*	SW2-UR	Swirl Ring 130A	1
2.	T-11335	S2	Shield 40A	10	*12.	T-13144*	SW4-UR	Swirl Ring 260A SS 50mm+	1
3.	T-11336	S3	Shield 80/130A	10	13.	T-13138	E2	Electrode 45-80A, F5-N ₂	5
4.	T-13143	S5	Shield 260A SS, AL	10	14.	T-11342	E1	Electrode 130A	5
5.	T-13141	G2	Gas Ring 45-80A 130-260A SS, AL	1	15.	T-13139	E4	Electrode 130A-260A, H35-N ₂	5
6.	T-13142	G3	Gas Ring 260A SS	1	16.	T-13140	E5	Electrode 260A SS 50mm+	5
7.	T-11330	N2	Nozzle 40A	1	17.	T-11327	B1	Cooling Tube	1
8.	T-12263	N6	Nozzle 130A SS	1	*18.	T-11351*	100-07-106535-UR	Consumable Removal Tool	1
9.	T-12265	N9	Nozzle 260A SS, AL, H35/N ₂	1					
10.	T-11338	SW1-UR	Swirl Ring 30-80A	1					

* FULLY INTERCHANGEABLE AND COMPATIBLE WITH ORIGINAL PARTS, BUT DIFFERS FROM ORIGINAL DESIGN

THERMACUT®, FHT-EX® AND EX-TRAFIRE® ARE REGISTERED TRADEMARKS OF THERMACUT, K. S. AND MAY BE REGISTERED IN CZECH REPUBLIC AND/OR OTHER COUNTRIES. ALL OTHER TRADEMARKS ARE PROPERTIES OF THEIR RESPECTIVE OWNERS. THERMACUT IS NO WAY AFFILIATED WITH AJAN®. MOST THERMACUT PARTS ARE MADE FOR OR BY AN IBG COMPANY. PARTS INDICATED WITH A OEM ARE ORIGINAL PARTS MANUFACTURED BY THE ABOVE NAMED MANUFACTURER AND ARE BEING RESOLD BY THERMACUT. THERMACUT RESERVES THE RIGHT TO SUBSTITUTE OEM PARTS IN PLACE OF THERMACUT PARTS. VALID FROM SEPTEMBER 2024 • PREVIOUS VERSION IS NO LONGER VALID. • © COPYRIGHT 2024 BY THERMACUT® CZECH REPUBLIC. ALL RIGHTS RESERVED.

**THERMACUT® REPLACEMENT PARTS SUITABLE FOR
ESAB®/L-TEC®
PT-15™, PT-15XL™**

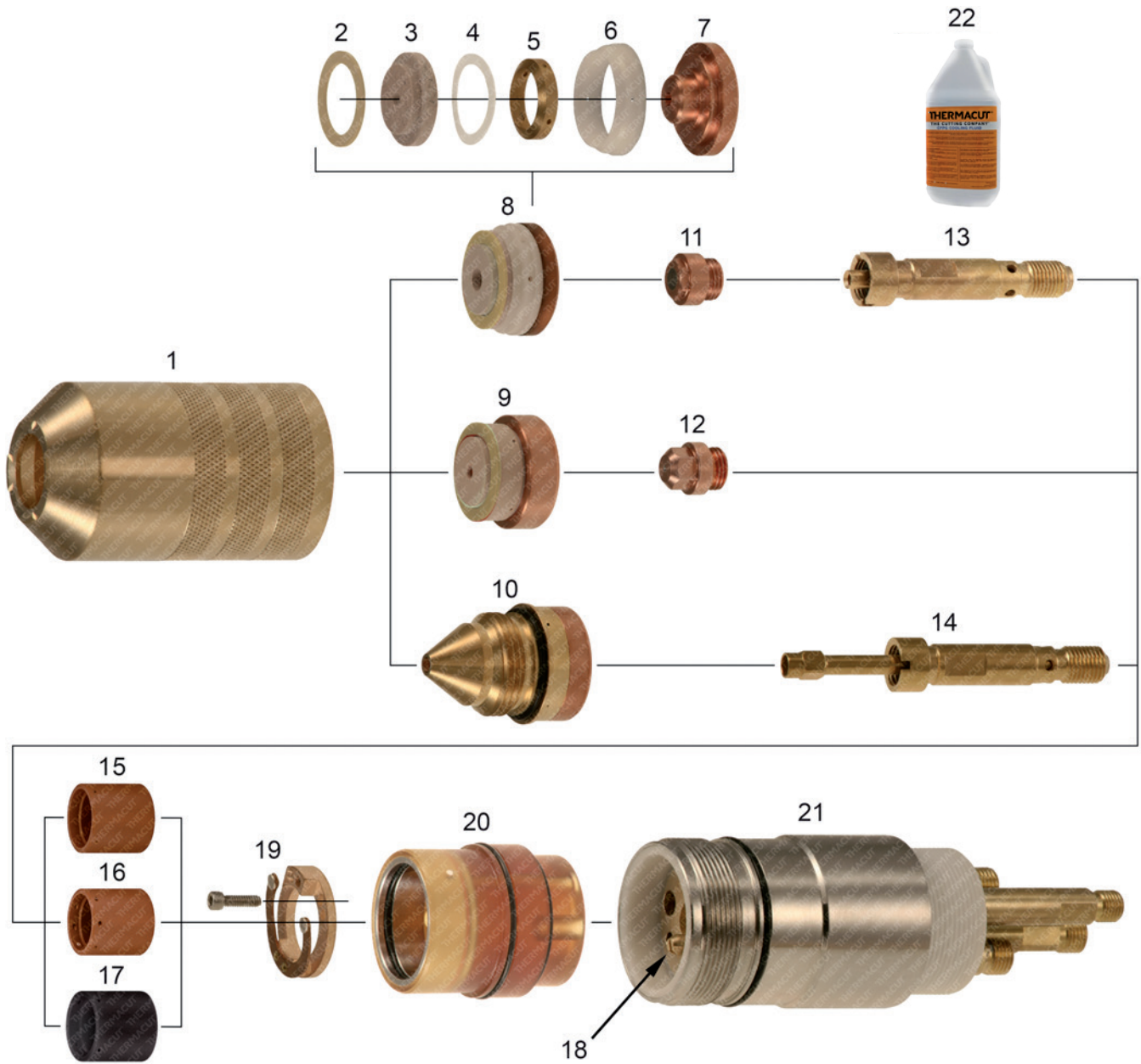

THERMACUT®, FHT-EX® AND EX-TRAFIRE® ARE REGISTERED TRADEMARKS OF THERMACUT, K. S. AND MAY BE REGISTERED IN CZECH REPUBLIC AND/OR OTHER COUNTRIES. ALL OTHER TRADEMARKS ARE PROPERTIES OF THEIR RESPECTIVE OWNERS. THERMACUT IS NO WAY AFFILIATED WITH ESAB®/L-TEC®. MOST THERMACUT PARTS ARE MADE FOR OR BY AN IBG COMPANY. PARTS INDICATED WITH A OEM ARE ORIGINAL PARTS MANUFACTURED BY THE ABOVE NAMED MANUFACTURER AND ARE BEING RESOLD BY THERMACUT. THERMACUT RESERVES THE RIGHT TO SUBSTITUTE OEM PARTS IN PLACE OF THERMACUT PARTS. VALID FROM SEPTEMBER 2024 • PREVIOUS VERSION IS NO LONGER VALID. • © COPYRIGHT 2024 BY THERMACUT® CZECH REPUBLIC. ALL RIGHTS RESERVED.

**THERMACUT® REPLACEMENT PARTS SUITABLE FOR
ESAB®/L-TEC®
PT-15™, PT-15XL™**

Item	Part No.	Ref. No.	Description	Std. Pkg.	Item	Part No.	Ref. No.	Description	Std. Pkg.
1.	T-0355	20758	Nozzle Retaining Cup, O ₂	1	OD NS	T-11325	0558005866	Nozzle 400A, Bevel, O ₂	1
2.	T-0354	996628	Gasket	5	11.	T-0328	600236	Electrode 250-1000A, N ₂	5
3.	T-0350	2075693	Insulator 0.140"	5	12.	T-0329	20763	Electrode 260A, O ₂	5
	T-0351	2075617	Insulator 0.180"	5	13.	T-0326	2075343	Electrode Holder	1
	T-0352	2075606	Insulator 0.225"	5	14.	T-1253	34084	Electrode Holder	1
	T-1604	2075588	Insulator 0.500"	5	15.	T-0322	948142	Gas Swirl Baffle, 4 Hole, CW	1
NS	T-10683	20409-UR	Insulator	5	16.	T-2019	35660	Gas Swirl Baffle, 8 Hole, CW	1
4.	T-0349	996619	Spacer	1	OD 17.	T-1869	1361201	Gas Swirl Baffle, 8 Hole, CW	1
5.	T-0346	2075584	Swirl Ring, 4 Hole, CW	1	18.	T-1247	996242	Locating Pin	5
	PT-10567	2075616	Swirl Ring, 4 Hole, CCW	1	OD 19.	T-1248	21940 OEM	Contact Ring	1
6.	T-0348	996618	Centering Sleeve	1	20.	T-0319	20755	Insulator	1
7.	T-0345	19810	Nozzle Base 875-1000A	1	21.	T-0318	20754	Torch Body, Machine	1
	T-0342	2075608	Nozzle Base 400A	1	NS	KT-1447	20762	PT-15XL™ Torch with Leads 1.8m (6')	1
	T-0343	2075609	Nozzle Base 600A	1	NS	T-13231	K.PT-15XL.3M	PT-15XL™ Torch with Leads 3m (10')	1
8.	T-0332	2075611	Nozzle 400A, N ₂	1	NS	KT-1159	000128	PT-15XL™ Cable Leads 1.8m (6')	1
	T-1966	2075612	Nozzle 600A, N ₂	1	NS	KT-1118	K.PT-15XL.3M.K	PT-15XL™ Cable Leads 3m (10')	1
OD	T-0338	2075587	Nozzle 875-1000A, H35	1	NS	KT-1160	000124	PT-15XL™ Cable Leads 5.1m (17')	1
	T-1976	2075691	Nozzle 250A, N ₂	1	NS	KT-1158	000129	PT-15XL™ Cable Leads 6.1m (20')	1
OD 9.	T-1716	35664	Nozzle 340A, O ₂	1	NS	KT-1105	000328	PT-15XL™ Cable Leads 7.6m (25')	1
	T-0339	20751	Nozzle 260A, O ₂	1	22.	Coolant Liquid. Details on the Accessories page.			
OD	T-1715	35662	Nozzle 300A, O ₂	1					
OD 10.	T-10209	21962	Nozzle 300A, Bevel, O ₂	1					

OD ON DEMAND – WE DO NOT KEEP THESE PARTS IN STOCK, COST IS SET ACCORDING TO THE ORDERED QUANTITY, DELIVERY TIME MAY DIFFER FROM STANDARD PRODUCTS.

CCW COUNTER CLOCK WISE GAS SWIRLING, USE OF CCW PARTS WILL MAKE CUT ANGLE ON THE OPPOSITE SIDE, THAN WITH STANDARD CLOCK WISE (CW) SWIRLING PARTS.

NS NOT SHOWN IN THE PICTURE

THERMACUT®, FHT-EX® AND EX-TRAFIRE® ARE REGISTERED TRADEMARKS OF THERMACUT, K. S. AND MAY BE REGISTERED IN CZECH REPUBLIC AND/OR OTHER COUNTRIES. ALL OTHER TRADEMARKS ARE PROPERTIES OF THEIR RESPECTIVE OWNERS. THERMACUT IS NO WAY AFFILIATED WITH ESAB®/L-TEC®. MOST THERMACUT PARTS ARE MADE FOR OR BY AN IBG COMPANY. PARTS INDICATED WITH A OEM ARE ORIGINAL PARTS MANUFACTURED BY THE ABOVE NAMED MANUFACTURER AND ARE BEING RESOLD BY THERMACUT. THERMACUT RESERVES THE RIGHT TO SUBSTITUTE OEM PARTS IN PLACE OF THERMACUT PARTS. VALID FROM SEPTEMBER 2024 • PREVIOUS VERSION IS NO LONGER VALID. • © COPYRIGHT 2024 BY THERMACUT® CZECH REPUBLIC. ALL RIGHTS RESERVED.

**THERMACUT® REPLACEMENT PARTS SUITABLE FOR
ESAB®/L-TEC®
PT-15™, PT-15XL™ TORCH**

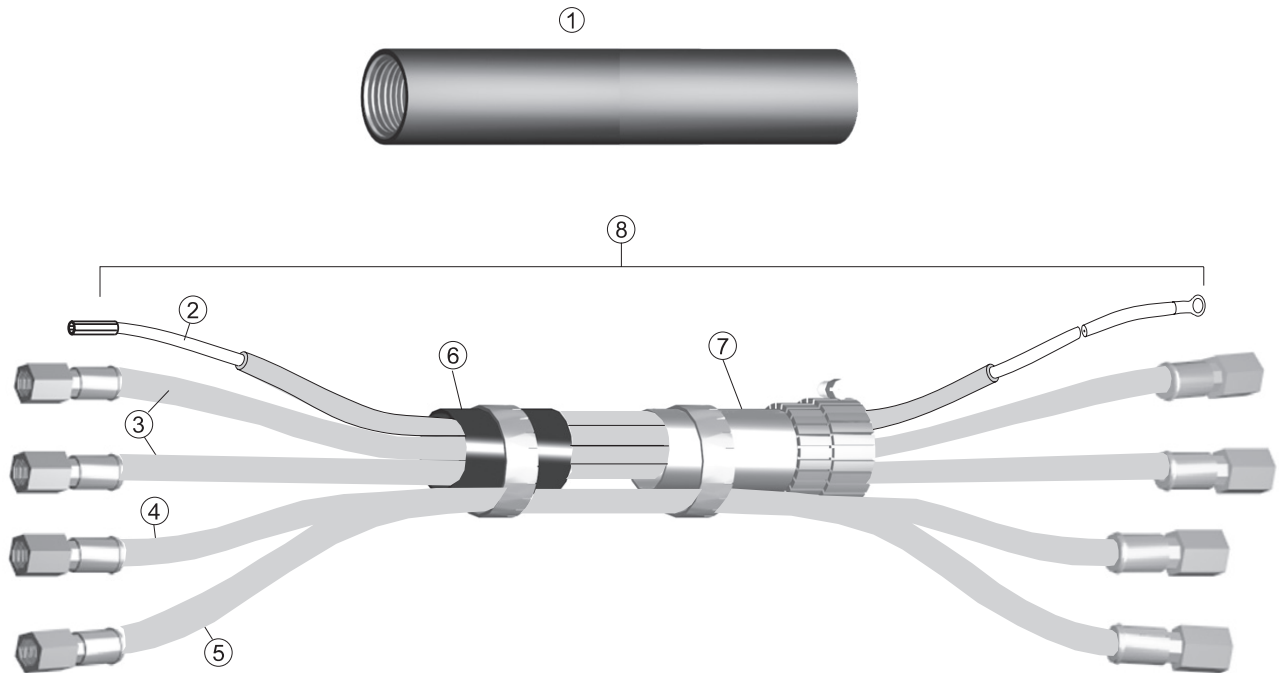

THERMACUT®, FHT-EX® AND EX-TRAFIRE® ARE REGISTERED TRADEMARKS OF THERMACUT, K. S. AND MAY BE REGISTERED IN CZECH REPUBLIC AND/OR OTHER COUNTRIES. ALL OTHER TRADEMARKS ARE PROPERTIES OF THEIR RESPECTIVE OWNERS. THERMACUT IS NO WAY AFFILIATED WITH ESAB®/L-TEC®. MOST THERMACUT PARTS ARE MADE FOR OR BY AN IBG COMPANY. PARTS INDICATED WITH A OEM ARE ORIGINAL PARTS MANUFACTURED BY THE ABOVE NAMED MANUFACTURER AND ARE BEING RESOLD BY THERMACUT. THERMACUT RESERVES THE RIGHT TO SUBSTITUTE OEM PARTS IN PLACE OF THERMACUT PARTS. VALID FROM SEPTEMBER 2024 • PREVIOUS VERSION IS NO LONGER VALID. • © COPYRIGHT 2024 BY THERMACUT® CZECH REPUBLIC. ALL RIGHTS RESERVED.

**THERMACUT® REPLACEMENT PARTS SUITABLE FOR
ESAB®/L-TEC®
PT-15™, PT-15XL™ TORCH**

Item	Part No.	Ref. No.	Description	Std. Pkg.	Item	Part No.	Ref. No.	Description	Std. Pkg.
1.	T-1337	19483	Insulating Sleeve	1		T-2314	602713	Gas Hose, 8', PCM-8	1
2.	T-2309	34357	Pilot Arc Cable, 6', ESP	1	5.	T-2311	34354	Injection Hose, 6', ESP	1
	T-1339	34358	Pilot Arc Cable, 12', ESP	1		T-1354	34355	Injection Hose, 12', ESP	1
	T-1340	21263	Pilot Arc Cable, 15', ESP	1		T-1355	21257	Injection Hose, 15', ESP	1
	T-1341	21264	Pilot Arc Cable, 20', ESP	1		T-1356	21258	Injection Hose, 20', ESP	1
	T-1342	21265	Pilot Arc Cable, 25', ESP	1		T-1357	21259	Injection Hose, 25', ESP	1
	T-1961	20760	Pilot Arc Cable, 6', PCM-8	1		T-1353	996250	Injection Hose, 6', PCM-8	1
	T-2312	602715	Pilot Arc Cable, 8', PCM-8	1		T-2315	602714	Injection Hose, 8', PCM-8	1
	T-4020	996251	Pilot Arc Cable	1	6.	T-1358	T-1358	Tubing	1
3.	T-1343	996248	Power Cable, 6', ESP	1	7.	T-1359	T-1359	Shielding Braid	1
	T-1344	34363	Power Cable, 12', ESP	1	8.	T-1360	T-1360	Lead Package, 6', ESP	1
	T-1345	21266	Power Cable, 15', ESP	1		T-1361	T-1361	Lead Package, 12', ESP	1
	T-1346	21267	Power Cable, 20', ESP	1		T-1362	T-1362	Lead Package, 15', ESP	1
	T-1347	21268	Power Cable, 25', ESP	1		T-1363	T-1363	Lead Package, 20', ESP	1
	T-1343	996248	Power Cable, 6', PCM-8	1		T-1364	T-1364	Lead Package, 25', ESP	1
	T-2313	602712	Power Cable, 8', PCM-8	1		T-0999	T-0999	Lead Package, 6', PCM-8	1
4.	T-2310	34360	Gas Hose, 6', ESP	1		T-1365	T-1365	Lead Package, 8', PCM-8	1
	T-1349	34361	Gas Hose, 12', ESP	1	NS	T-1370	20408 OEM	Connector, H.F.	1
	T-1350	21260	Gas Hose, 15', ESP	1	NS	T-1371	20409 OEM	Insulator, H.F.	1
	T-1351	21261	Gas Hose, 20', ESP	1	NS	T-1372	21082 OEM	H.F. Wire	1
	T-1352	21262	Gas Hose, 25', ESP	1	NS	T-1373	20403 OEM	Wire Insulator	1
	T-1348	996249	Gas Hose, 6', PCM-8	1					

NS NOT SHOWN IN THE PICTURE

THERMACUT®, FHT-EX® AND EX-TRAFIRE® ARE REGISTERED TRADEMARKS OF THERMACUT, K. S. AND MAY BE REGISTERED IN CZECH REPUBLIC AND/OR OTHER COUNTRIES. ALL OTHER TRADEMARKS ARE PROPERTIES OF THEIR RESPECTIVE OWNERS. THERMACUT IS NO WAY AFFILIATED WITH ESAB®/L-TEC®. MOST THERMACUT PARTS ARE MADE FOR OR BY AN IBG COMPANY. PARTS INDICATED WITH A OEM ARE ORIGINAL PARTS MANUFACTURED BY THE ABOVE NAMED MANUFACTURER AND ARE BEING RESOLD BY THERMACUT. THERMACUT RESERVES THE RIGHT TO SUBSTITUTE OEM PARTS IN PLACE OF THERMACUT PARTS. VALID FROM SEPTEMBER 2024 • PREVIOUS VERSION IS NO LONGER VALID. • © COPYRIGHT 2024 BY THERMACUT® CZECH REPUBLIC. ALL RIGHTS RESERVED.

**THERMACUT® REPLACEMENT PARTS SUITABLE FOR
ESAB®/L-TEC®
PT-19XLS™**

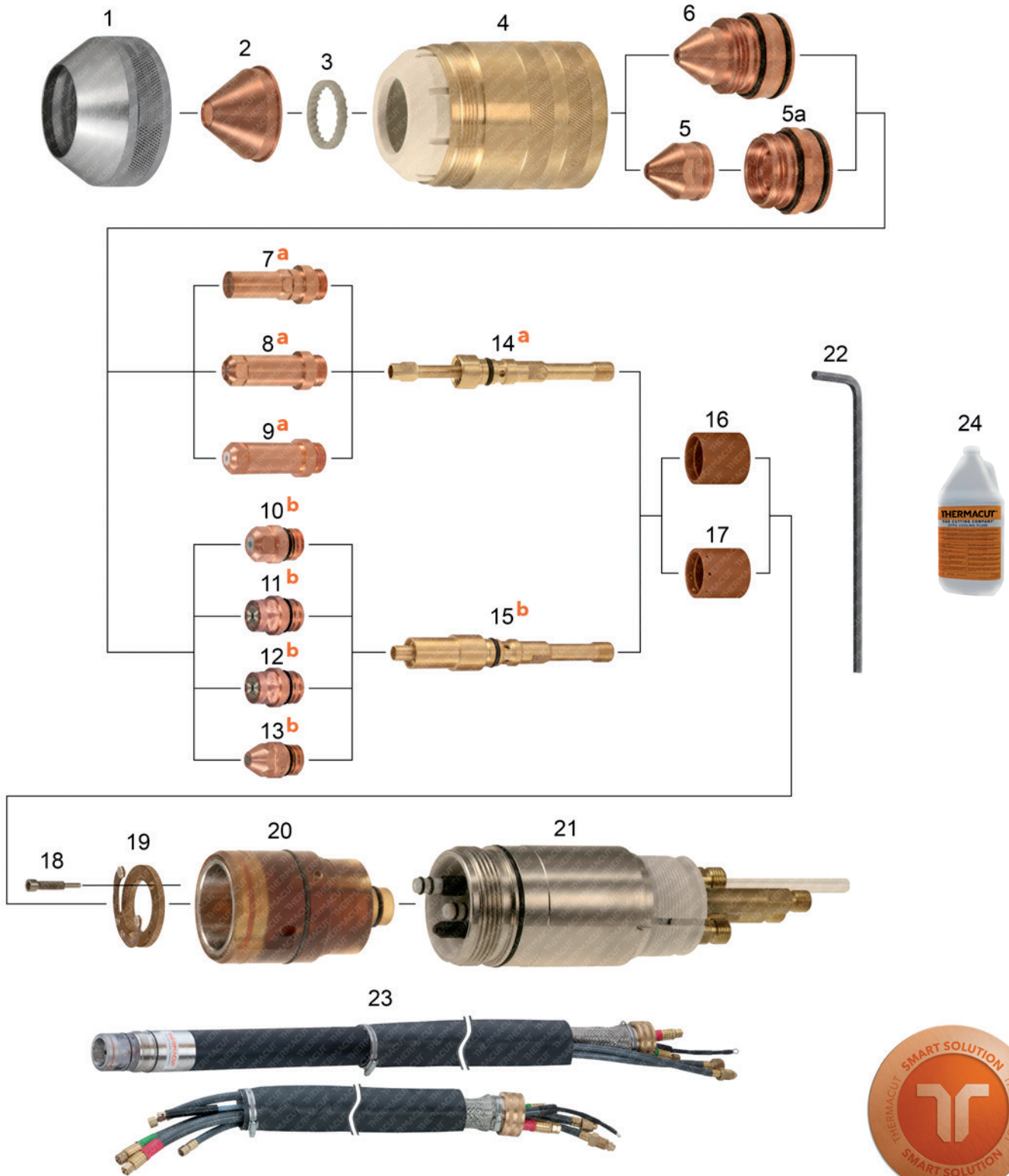

THERMACUT®, FHT-EX® AND EX-TRAFIRE® ARE REGISTERED TRADEMARKS OF THERMACUT, K. S. AND MAY BE REGISTERED IN CZECH REPUBLIC AND/OR OTHER COUNTRIES. ALL OTHER TRADEMARKS ARE PROPERTIES OF THEIR RESPECTIVE OWNERS. THERMACUT IS NO WAY AFFILIATED WITH ESAB®/L-TEC®. MOST THERMACUT PARTS ARE MADE FOR OR BY AN IBG COMPANY. PARTS INDICATED WITH A OEM ARE ORIGINAL PARTS MANUFACTURED BY THE ABOVE NAMED MANUFACTURER AND ARE BEING RESOLD BY THERMACUT. THERMACUT RESERVES THE RIGHT TO SUBSTITUTE OEM PARTS IN PLACE OF THERMACUT PARTS. VALID FROM SEPTEMBER 2024 • PREVIOUS VERSION IS NO LONGER VALID. • © COPYRIGHT 2024 BY THERMACUT® CZECH REPUBLIC. ALL RIGHTS RESERVED.

THERMACUT® REPLACEMENT PARTS SUITABLE FOR ESAB®/L-TEC® PT-19XLS™



Item	Part No.	Ref. No.	Description	Std. Pkg.	Item	Part No.	Ref. No.	Description	Std. Pkg.
1.	T-10128	37081	Shield Retainer	1	b 12.	T-11994	0558012000-PRO	Electrode 100-450A, O ₂ , Silver PRO	5
2.		21795 OEM	Shield 50A	1	b 13.	T-11910	0558003928-UR	Electrode, N ₂ /H35	5
	T-2266	21802	Shield 100-250A	1	a 14.	T-2349	37068	Electrode Holder	1
	T-2267	21945	Shield 325-600A	1	b 15.	T-11210	T-11210	Electrode Holder	1
3.	T-2269	21944	Diffuser 100-600A	1	16.	T-0322	948142	Gas Swirl Baffle, 4 Hole, CW	1
4.	T-10129	37082	Nozzle Retaining Cap	1		T-0323	948143	Gas Swirl Baffle, 4 Hole CCW	1
5.	T-1720	22026	Nozzle Tip 50A	5	17.	T-2019	35660	Gas Swirl Baffle, 8 Hole, CW	1
	T-1717	22029	Nozzle Tip 100A	5		T-11659	35661	Gas Swirl Baffle, 8 Hole CCW	1
	T-1718	22030	Nozzle Tip 150A	5	18.	T-11942	37073	Screw	1
5a.	T-1721	22027	Nozzle Base 50A	1	19.	T-11863	0558003858	Cont. Ring with 2pcs. Screws 37073 (=37071)	1
	T-1722	22028	Nozzle Base 100-250A	1	20.	T-2351	37083 OEM	Insulator	10
6.	T-2271	21822	Nozzle 250A	1	OD 21.	T-3422	37066	Torch Body PT-19XLS™, Machine	1
a 7.	T-10266*	35886-UR	Electrode 360A	5	OD NS	T-11202	T-11202	Electrode Holder Wrench	1
a 8.	T-10262	34086-UR	Electrode 50-250A	5	22.	N-20426	93750010	Hex Key Wrench for Contact Ring	1
a 9.	T-1252	34086	Electrode 50-250A	5	23.	Cable Leads are available on request, because of more possible types of fittings.			
a 9.	T-11857	34086-PRO	Electrode 50-250A, Silver PRO	5	24.	Coolant Liquid. Details on the Accessories page.			
b 10.	T-11303	T-11303-PRO	Electrode 50-250A, Silver PRO	5					
b 11.	T-11290*	0558003914-PRO	Electrode 100-450A, O ₂ , Silver PRO	5					

ACCESSORIES

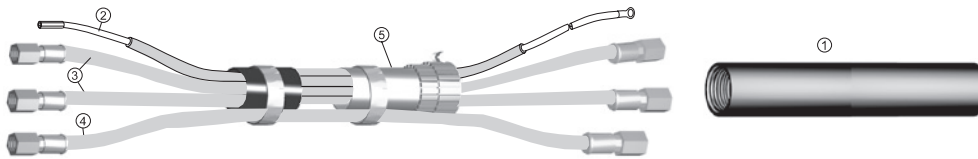

Item	Part No.	Ref. No.	Description	Std. Pkg.	Item	Part No.	Ref. No.	Description	Std. Pkg.
1.	T-1337	19483	Insulating Sleeve	1		T-1347	21268	Power Cable, 25'	1
2.	T-2309	34357	Pilot Arc Cable, 6'	1	4.	T-2310	34360	Gas Hose, 6'	1
	T-1339	34358	Pilot Arc Cable, 12'	1		T-1349	34361	Gas Hose, 12'	1
	T-1340	21263	Pilot Arc Cable, 15'	1		T-1350	21260	Gas Hose, 15'	1
	T-1341	21264	Pilot Arc Cable, 20'	1		T-1351	21261	Gas Hose, 20'	1
	T-1342	21265	Pilot Arc Cable, 25'	1		T-1352	21262	Gas Hose, 25'	1
3.	T-1343	996248	Power Cable, 6'	1	5.	T-1359	T-1359	Shielding Braid	1
	T-1344	34363	Power Cable, 12'	1					
	T-1345	21266	Power Cable, 15'	1					
	T-1346	21267	Power Cable, 20'	1					

- a** MUST BE USED ONLY AS A SET OF ELECTRODE HOLDER 37068 AND 35886-UR, 34086XL-AG, 34086-UR, 34086, 34086-PRO ELECTRODES.
- b** MUST BE USED ONLY AS A SET OF ELECTRODE HOLDER T-11210 AND T-11303-PRO, 0558003914-PRO, 0558012000-PRO, 0558003928-UR ELECTRODES.
- OD** ON DEMAND – WE DO NOT KEEP THESE PARTS IN STOCK, COST IS SET ACCORDING TO THE ORDERED QUANTITY, DELIVERY TIME MAY DIFFER FROM STANDARD PRODUCTS.
- *** A UNIQUE DESIGN WHICH ENHANCES PERFORMANCE AND DIFFERS FROM OEM DESIGNS.
- CCW** COUNTER CLOCK WISE GAS SWIRLING, USE OF CCW PARTS WILL MAKE CUT ANGLE ON THE OPPOSITE SIDE, THAN WITH STANDARD CLOCK WISE (CW) SWIRLING PARTS.
- PRO** SILVER PRO TECHNOLOGY INCREASES ELECTRODE LIFETIME SIGNIFICANTLY COMPARED TO STANDARD COPPER ELECTRODES.
- NS** NOT SHOWN IN THE PICTURE

SMART SOLUTION - DESIGN IMPROVEMENTS THAT BRINGS ADDED VALUE SUCH AS IMPROVED LIFETIME OF CONSUMABLES, EXCELLENT CUT QUALITY, SPEED OR BETTER COST EFFECTIVENESS OF YOUR SYSTEM.

THERMACUT®, FHT-EX® AND EX-TRAFIRE® ARE REGISTERED TRADEMARKS OF THERMACUT, K. S. AND MAY BE REGISTERED IN CZECH REPUBLIC AND/OR OTHER COUNTRIES. ALL OTHER TRADEMARKS ARE PROPERTIES OF THEIR RESPECTIVE OWNERS. THERMACUT IS NO WAY AFFILIATED WITH ESAB®/L-TEC®. MOST THERMACUT PARTS ARE MADE FOR OR BY AN IBG COMPANY. PARTS INDICATED WITH A OEM ARE ORIGINAL PARTS MANUFACTURED BY THE ABOVE NAMED MANUFACTURER AND ARE BEING RESOLD BY THERMACUT. THERMACUT RESERVES THE RIGHT TO SUBSTITUTE OEM PARTS IN PLACE OF THERMACUT PARTS. VALID FROM SEPTEMBER 2024 • PREVIOUS VERSION IS NO LONGER VALID. • © COPYRIGHT 2024 BY THERMACUT® CZECH REPUBLIC. ALL RIGHTS RESERVED.

**THERMACUT® REPLACEMENT PARTS SUITABLE FOR
ESAB®/L-TEC®
PT-23™**

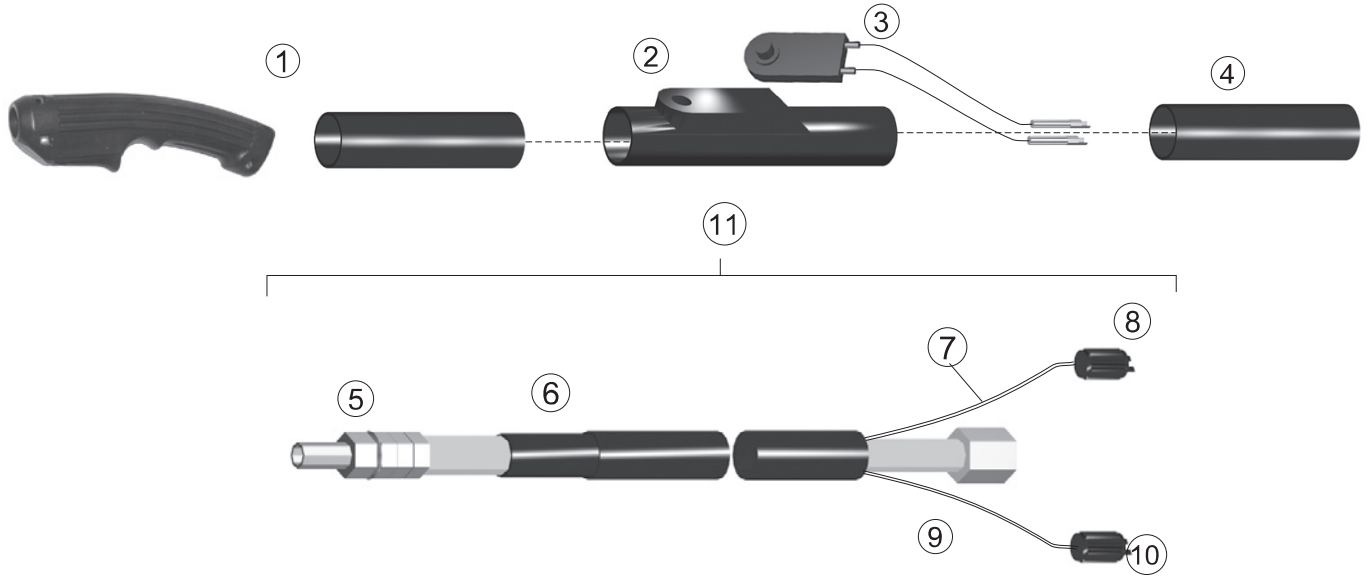

Item	Part No.	Ref. No.	Description	Std. Pkg.	Item	Part No.	Ref. No.	Description	Std. Pkg.
1.	T-1258	33419	Shield	1	5.	T-1264	33366	Electrode	10
OD 2.	T-1259	33371	Retaining Nut	1	6.	T-1265	21421	Torch Head	1
3.	T-1260	33368	Nozzle 30A	10	7.	T-1986	21420	Stand-off Guide	1
	T-1261	33369	Nozzle 50A	10	8., 9.	Not available any more – OEM only.			
	T-1262	33418	Nozzle 80A	10					
4.	T-1263	33367	Swirl Baffle	5					

ACCESSORIES

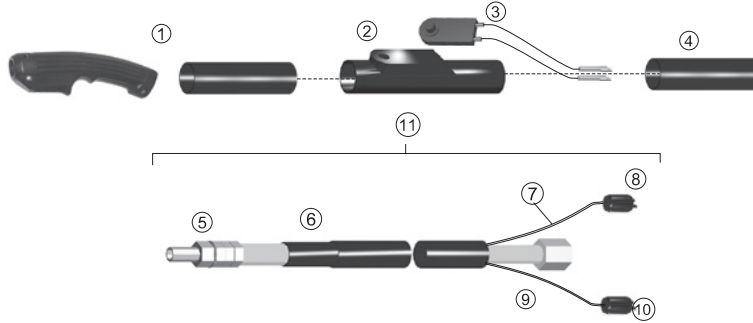

Item	Part No.	Ref. No.	Description	Std. Pkg.	Item	Part No.	Ref. No.	Description	Std. Pkg.
1.	T-1266	33399 OEM	Handle	1	8.	T-1187	2062336 OEM	Plug	1
2.	T-1267	33400 OEM	Switch Band	1	9.	T-1275	T-1275	Pilot Arc Lead, 25',w/plug	1
3.	T-1179	18224	Switch	1		T-1276	T-1276	Pilot Arc Lead, 50',w/plug	1
4.	T-1268	21218 OEM	Flex Support	1	10.	T-1277	21427 OEM	Plug	1
5.	T-1269	19995	Power Cable, 25'	1	11.	T-1278	T-1278	Leads Ass'y, 25',w/plug	1
	T-1270	19996	Power Cable, 50'	1		T-1279	T-1279	Leads Ass'y, 50',w/plug	1
6.	T-1271	18320	Sheath, 25'	1	NS	T-2331	21402	Complete Ass'y, 25',w/plug	1
	T-1272	19026	Sheath, 50'	1	NS	T-2332	21403	Complete Ass'y, 50',w/plug	1
7.	T-1273	T-1273	Control Cable, 25'	1	NS	T-1326	49N83	Boot	1
	T-1274	T-1274	Control Cable, 50'	1					

OD ON DEMAND – WE DO NOT KEEP THESE PARTS IN STOCK, COST IS SET ACCORDING TO THE ORDERED QUANTITY, DELIVERY TIME MAY DIFFER FROM STANDARD PRODUCTS.

THERMACUT®, FHT-EX® AND EX-TRAFIRE® ARE REGISTERED TRADEMARKS OF THERMACUT, K. S. AND MAY BE REGISTERED IN CZECH REPUBLIC AND/OR OTHER COUNTRIES. ALL OTHER TRADEMARKS ARE PROPERTIES OF THEIR RESPECTIVE OWNERS. THERMACUT IS NO WAY AFFILIATED WITH ESAB®/L-TEC®. MOST THERMACUT PARTS ARE MADE FOR OR BY AN IBG COMPANY. PARTS INDICATED WITH A OEM ARE ORIGINAL PARTS MANUFACTURED BY THE ABOVE NAMED MANUFACTURER AND ARE BEING RESOLD BY THERMACUT. THERMACUT RESERVES THE RIGHT TO SUBSTITUTE OEM PARTS IN PLACE OF THERMACUT PARTS. VALID FROM SEPTEMBER 2024 • PREVIOUS VERSION IS NO LONGER VALID. • © COPYRIGHT 2024 BY THERMACUT® CZECH REPUBLIC. ALL RIGHTS RESERVED.

**THERMACUT® REPLACEMENT PARTS SUITABLE FOR
ESAB®/L-TEC®
PT-24™**

PRODUCT BROCHURE WITH DETAILS AT
WWW.THERMACUT.COM

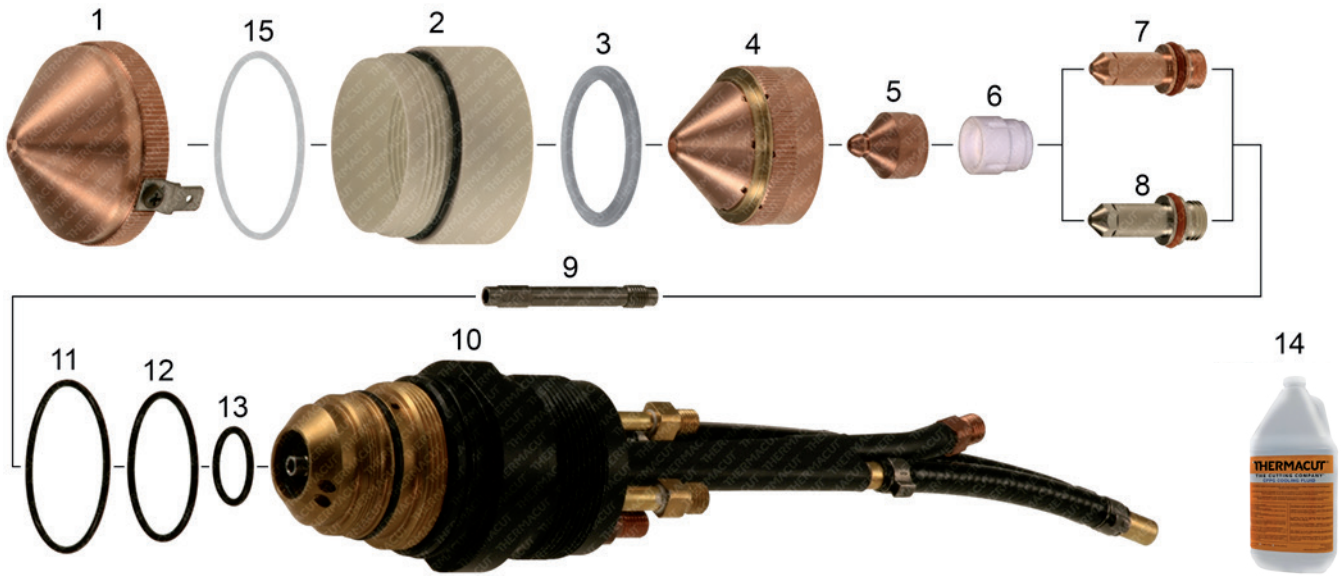

Item	Part No.	Ref. No.	Description	Std. Pkg.	Item	Part No.	Ref. No.	Description	Std. Pkg.
1.	T-10130	22531	Cup Shield with Retainer	1	9.	PT-10625	21725	Water Baffle	1
2.	T-9333	21712	Insulator Shield Retainer	1	10.	T-3379	21758	PT-24™ Torch Body, Machine	1
3.	T-3350	22010	Shield Cap Insulator	1	11.	T-2824	950714	O-Ring	1
4.	T-3353	22007	Nozzle Retainer/Diffuser	1	OD 12.	T-4019	86W62	O-Ring	10
5.	T-3372	21542	Nozzle "C" 50A	5	13.	T-4018	638797	O-Ring	10
	T-3354	21923	Nozzle "E" 100A	5	14.	Coolant Liquid. Details on the Accessories page.			
OD 6.	T-3376	21692 OEM	Swirl Baffle 50-100A	10	15.	Not available any more – OEM only.			
7.	T-3377	21539	Electrode	5					
	T-8987	21539-PRO	Electrode, Silver PRO	5					
8.	T-4916	21539-AG	Electrode, SilverEX-®	5					

OD ON DEMAND – WE DO NOT KEEP THESE PARTS IN STOCK, COST IS SET ACCORDING TO THE ORDERED QUANTITY, DELIVERY TIME MAY DIFFER FROM STANDARD PRODUCTS.

-PRO SILVER PRO TECHNOLOGY INCREASES ELECTRODE LIFETIME SIGNIFICANTLY COMPARED TO STANDARD COPPER ELECTRODES.

THERMACUT®, FHT-EX® AND EX-TRAFIRE® ARE REGISTERED TRADEMARKS OF THERMACUT, K. S. AND MAY BE REGISTERED IN CZECH REPUBLIC AND/OR OTHER COUNTRIES. ALL OTHER TRADEMARKS ARE PROPERTIES OF THEIR RESPECTIVE OWNERS. THERMACUT IS NO WAY AFFILIATED WITH ESAB®/L-TEC®. MOST THERMACUT PARTS ARE MADE FOR OR BY AN IBG COMPANY. PARTS INDICATED WITH A OEM ARE ORIGINAL PARTS MANUFACTURED BY THE ABOVE NAMED MANUFACTURER AND ARE BEING RESOLD BY THERMACUT. THERMACUT RESERVES THE RIGHT TO SUBSTITUTE OEM PARTS IN PLACE OF THERMACUT PARTS. VALID FROM SEPTEMBER 2024 • PREVIOUS VERSION IS NO LONGER VALID. • © COPYRIGHT 2024 BY THERMACUT® CZECH REPUBLIC. ALL RIGHTS RESERVED.

**THERMACUT® REPLACEMENT PARTS SUITABLE FOR
ESAB®/L-TEC®
PT-27™**

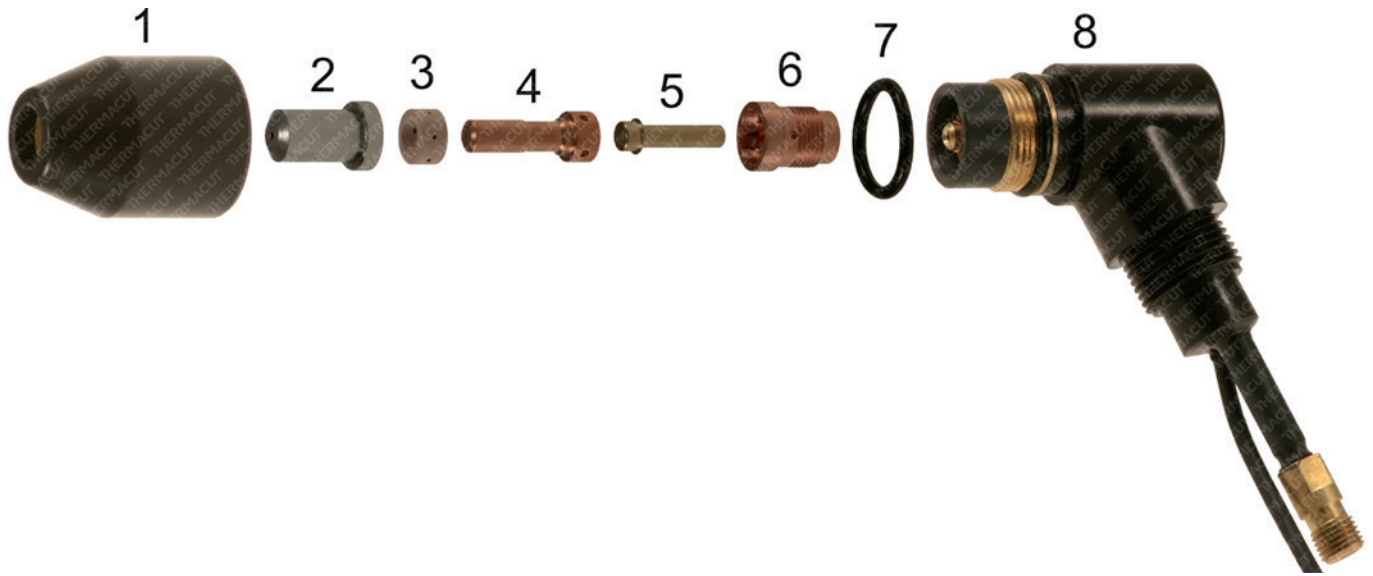

Item	Part No.	Ref. No.	Description	Std. Pkg.	Item	Part No.	Ref. No.	Description	Std. Pkg.
1.	T-1307	21616	Heat Shield	1	6.	T-1310	21615	Replaceable Seat	5
2.	T-1260	33368	Nozzle 0.9mm 30A	10	7.	T-1309	21610	Torch Body 70°	1
	T-1261	33369	Nozzle 1.2mm 50-70A	10	8.	T-1986	21420	Stand-off Guide	1
	T-1262	33418	Nozzle 1.3mm 80A	10	OD 9.	PT-10220	0558003032	Seat Assembly	1
	T-0057	35442	Gouging Nozzle 2.4mm	10	OD NS	T-3953	0558003027	Seat Installation Tool	1
3.	T-1263	33367	Swirl Baffle	5	NS	KT-1301	21620	PT-27™ Cable Leads 7.6m (25')	1
4.	T-1264	33366	Electrode	10	10.	Not available any more – OEM only.			
5.	T-1308	21619	Valve Pin	5	NS	T-2018	35443 OEM	Gouging Shield	1

OD ON DEMAND – WE DO NOT KEEP THESE PARTS IN STOCK, COST IS SET ACCORDING TO THE ORDERED QUANTITY, DELIVERY TIME MAY DIFFER FROM STANDARD PRODUCTS.

NS NOT SHOWN IN THE PICTURE

THERMACUT®, FHT-EX® AND EX-TRAFIRE® ARE REGISTERED TRADEMARKS OF THERMACUT, K. S. AND MAY BE REGISTERED IN CZECH REPUBLIC AND/OR OTHER COUNTRIES. ALL OTHER TRADEMARKS ARE PROPERTIES OF THEIR RESPECTIVE OWNERS. THERMACUT IS NO WAY AFFILIATED WITH ESAB®/L-TEC®. MOST THERMACUT PARTS ARE MADE FOR OR BY AN IBG COMPANY. PARTS INDICATED WITH A OEM ARE ORIGINAL PARTS MANUFACTURED BY THE ABOVE NAMED MANUFACTURER AND ARE BEING RESOLD BY THERMACUT. THERMACUT RESERVES THE RIGHT TO SUBSTITUTE OEM PARTS IN PLACE OF THERMACUT PARTS. VALID FROM SEPTEMBER 2024 • PREVIOUS VERSION IS NO LONGER VALID. • © COPYRIGHT 2024 BY THERMACUT® CZECH REPUBLIC. ALL RIGHTS RESERVED.

**THERMACUT® REPLACEMENT PARTS SUITABLE FOR
ESAB®/L-TEC®
PT-27™**

ACCESSORIES

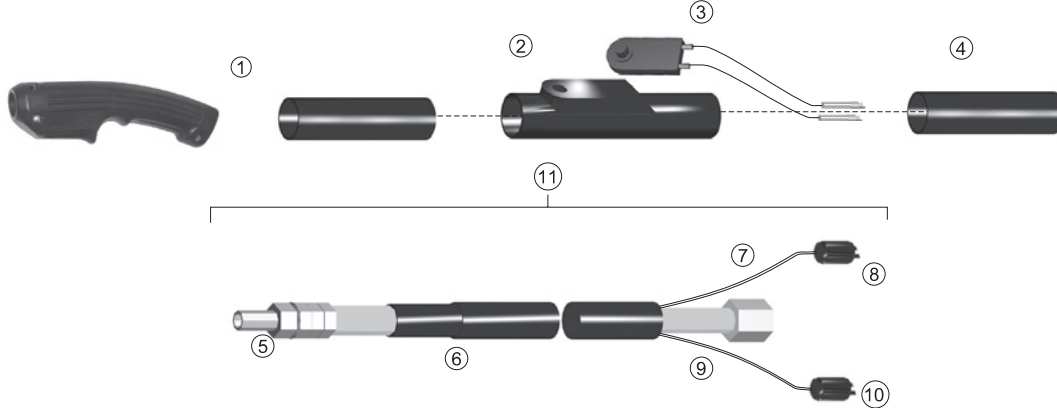

Item	Part No.	Ref. No.	Description	Std. Pkg.	Item	Part No.	Ref. No.	Description	Std. Pkg.
1.	T-1266	33399 OEM	Handle	1		T-2910	T-2910	Pilot Arc Lead, 25',w/plug	1
	T-1040	9-5636-1	Handle w/Switch	1		T-2911	T-2911	Pilot Arc Lead, 50',w/plug	1
2.	T-1267	33400 OEM	Switch Band	1	10.	T-1277	21427 OEM	Plug	1
3.	T-1179	18224	Switch	1	11.	T-2340	T-2340	Leads Ass'y, 25',w/ring	1
4.	T-1268	21218 OEM	Flex Support	1		T-2341	T-2341	Leads Ass'y, 50',w/ring	1
5.	T-1269	19995	Power Cable, 25'	1		T-2908	T-2908	Leads Ass'y, 25',w/plug	1
	T-1270	19996	Power Cable, 50'	1		T-2909	T-2909	Leads Ass'y, 50',w/plug	1
6.	T-1271	18320	Sheath, 25'	1	NS	T-1987	21661	Complete Ass'y, 25',w/ring	1
	T-1272	19026	Sheath, 50'	1	NS	T-2333	21662	Complete Ass'y, 50',w/ring	1
7.	T-1273	T-1273	Control Cable, 25'	1	NS	T-2334	21620	Complete Ass'y, 25',w/plug	1
	T-1274	T-1274	Control Cable, 50'	1	NS	T-2335	21621	Complete Ass'y, 50',w/plug	1
8.	T-1187	2062336 OEM	Plug	1	NS	T-1326	49N83	Boot	1
9.	T-2336	T-2336	Pilot Arc Lead, 25', w/ring	1					
	T-2337	T-2337	Pilot Arc Lead, 50', w/ring	1					

NS NOT SHOWN IN THE PICTURE

THERMACUT®, FHT-EX® AND EX-TRAFIRE® ARE REGISTERED TRADEMARKS OF THERMACUT, K. S. AND MAY BE REGISTERED IN CZECH REPUBLIC AND/OR OTHER COUNTRIES. ALL OTHER TRADEMARKS ARE PROPERTIES OF THEIR RESPECTIVE OWNERS. THERMACUT IS NO WAY AFFILIATED WITH ESAB®/L-TEC®. MOST THERMACUT PARTS ARE MADE FOR OR BY AN IBG COMPANY. PARTS INDICATED WITH A OEM ARE ORIGINAL PARTS MANUFACTURED BY THE ABOVE NAMED MANUFACTURER AND ARE BEING RESOLD BY THERMACUT. THERMACUT RESERVES THE RIGHT TO SUBSTITUTE OEM PARTS IN PLACE OF THERMACUT PARTS. VALID FROM SEPTEMBER 2024 • PREVIOUS VERSION IS NO LONGER VALID. • © COPYRIGHT 2024 BY THERMACUT® CZECH REPUBLIC. ALL RIGHTS RESERVED.

THERMACUT® REPLACEMENT PARTS SUITABLE FOR ESAB®/L-TEC® PT-31XL™



Item	Part No.	Ref. No.	Description	Std. Pkg.	Item	Part No.	Ref. No.	Description	Std. Pkg.
1.	T-1174	20860	Nozzle XT 30-40A	10		T-1175	21008	Nozzle 35-40A	10
	T-1176	20861	Nozzle XT 50A	10	2.	T-1173	20862	Electrode XT	10

ACCESSORIES

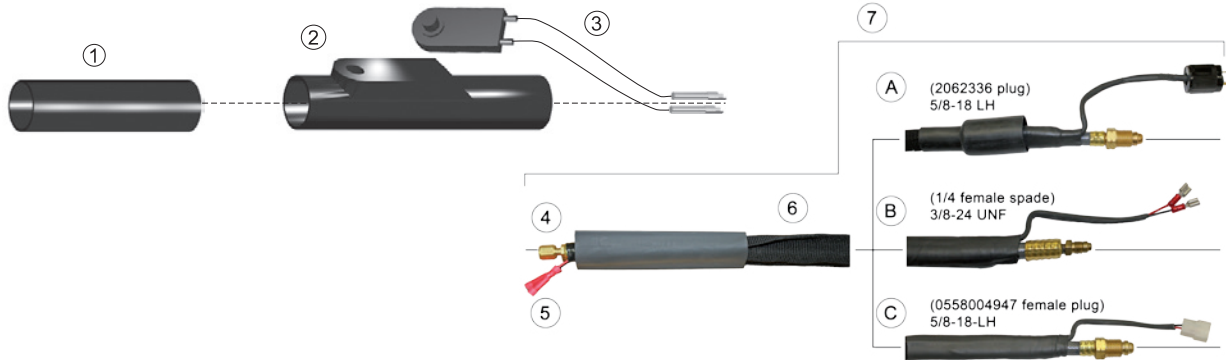

Item	Part No.	Ref. No.	Alt. Ref. No.	Description	Std. Pkg.	Item	Part No.	Ref. No.	Alt. Ref. No.	Description	Std. Pkg.
1.	T-1177	18208 OEM	0558000796	Handle	1	3.	T-1179	18224	0558000818	Switch	1
2.	T-1178	18207 OEM	0558000699	Switch Band	1	NS	T-1326	49N83	0558000793	Boot, Lead	1

Note: Must specify Power Supply when ordering leads to ensure correct connection fittings.

Item	Part No.	Ref. No.	Alt. Ref. No.	Description	Std. Pkg.	Item	Part No.	Ref. No.	Alt. Ref. No.	Description	Std. Pkg.
4.	T-1181	19672	0558005148	Power Cable, 15'	1		T-1272	19026	0558000792	Sheath, 50'	1
	T-1182	18221	0558000795	Power Cable, 25'	1	7.	T-1191	T-1191		Leads Assy, 15'	1
	T-1183	19028	0558005146	Power Cable, 50'	1		T-1192	T-1192		Leads Assy, 25'	1
5.	T-1188	T-1188		Control Cable, 15'	1		T-1193	19027		Leads Assy, 50'	1
	T-1189	T-1189		Control Cable, 25'	1			20085		Machine Torch w/ 12.5' Leads, 31	1
	T-1190	T-1190		Control Cable, 50'	1			20081		Machine Torch w/ 25' Leads, 31	1
6.	T-1184	19675	0558000583	Sheath, 15'	1			20083		Machine Torch w/ 50' Leads, 31	1
	T-1185	18320	0558000791	Sheath, 25'	1						

Part No.	Description	End Type	Power Supply	Part No.	Description	End Type	Power Supply
20084	Hand Torch w/ 12.5' Leads		CaddyCut® / HandyPlasma® 380	0558004482	Torch Assy w/ 15' Leads	C	HandyPlasma® 380
20080	Hand Torch w/ 25' Leads	A	HandyPlasma® 50 / PCM500i	0558004498	Torch Assy w/25' Leads	C	HandyPlasma® 550
20082	Hand Torch w/ 50' Leads			0558003183	Torch Assy w. 25' Leads	B	PowerCut® 650
0558005300	Torch Assy w/ 12.5' Leads	C	HandyPlasma® 250				

THERMACUT®, FHT-EX® AND EX-TRAFIRE® ARE REGISTERED TRADEMARKS OF THERMACUT, K. S. AND MAY BE REGISTERED IN CZECH REPUBLIC AND/OR OTHER COUNTRIES. ALL OTHER TRADEMARKS ARE PROPERTIES OF THEIR RESPECTIVE OWNERS. THERMACUT IS NO WAY AFFILIATED WITH ESAB®/L-TEC®. MOST THERMACUT PARTS ARE MADE FOR OR BY AN IBG COMPANY. PARTS INDICATED WITH A OEM ARE ORIGINAL PARTS MANUFACTURED BY THE ABOVE NAMED MANUFACTURER AND ARE BEING RESOLD BY THERMACUT. THERMACUT RESERVES THE RIGHT TO SUBSTITUTE OEM PARTS IN PLACE OF THERMACUT PARTS. VALID FROM SEPTEMBER 2024 • PREVIOUS VERSION IS NO LONGER VALID. • © COPYRIGHT 2024 BY THERMACUT® CZECH REPUBLIC. ALL RIGHTS RESERVED.

- This page intentionally left blank -

**THERMACUT® REPLACEMENT PARTS SUITABLE FOR
ESAB®/L-TEC®
PT-36™**

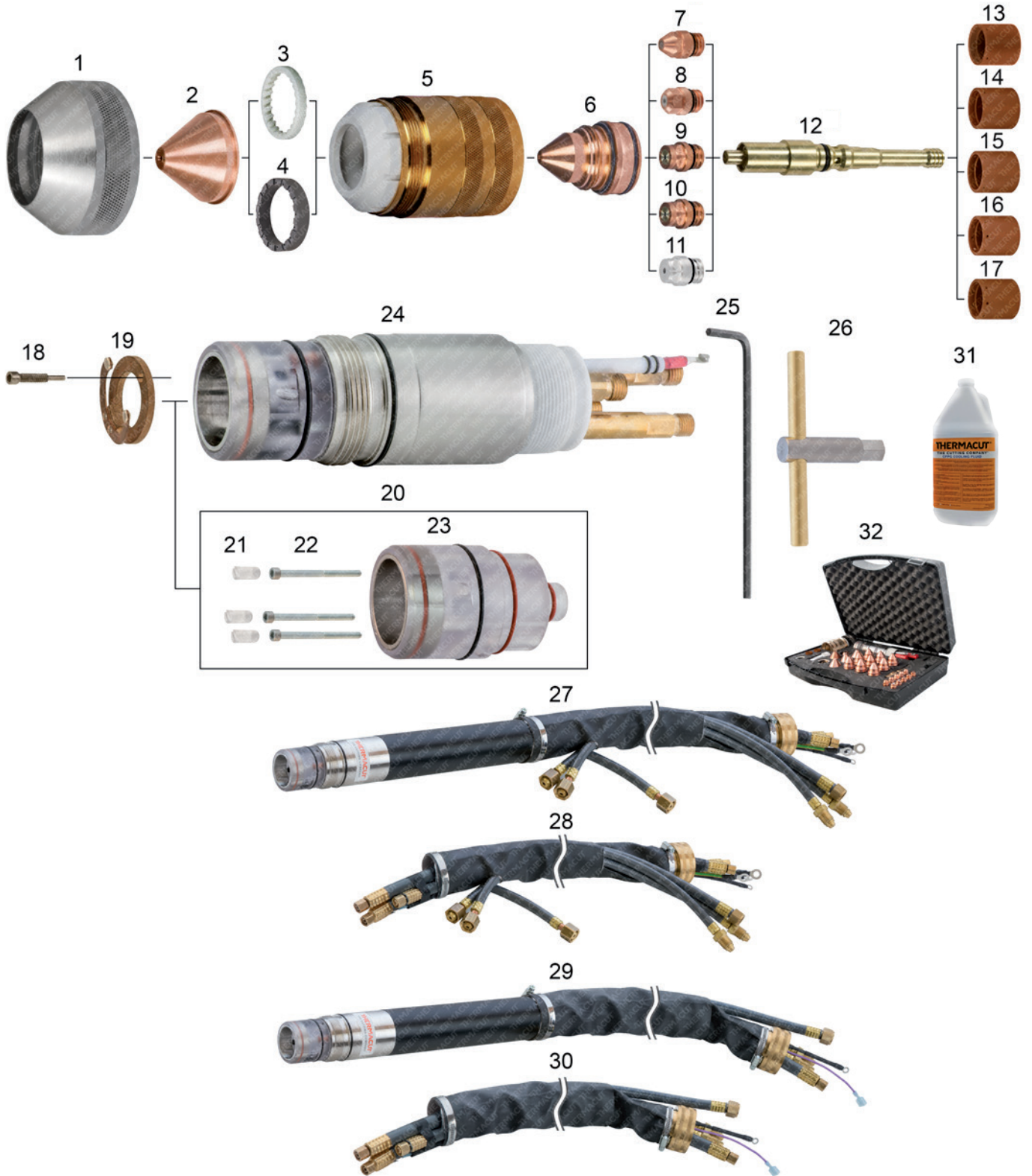

THERMACUT®, FHT-EX® AND EX-TRAFIRE® ARE REGISTERED TRADEMARKS OF THERMACUT, K. S. AND MAY BE REGISTERED IN CZECH REPUBLIC AND/OR OTHER COUNTRIES. ALL OTHER TRADEMARKS ARE PROPERTIES OF THEIR RESPECTIVE OWNERS. THERMACUT IS NO WAY AFFILIATED WITH ESAB®/L-TEC®. MOST THERMACUT PARTS ARE MADE FOR OR BY AN IBG COMPANY. PARTS INDICATED WITH A OEM ARE ORIGINAL PARTS MANUFACTURED BY THE ABOVE NAMED MANUFACTURER AND ARE BEING RESOLD BY THERMACUT. THERMACUT RESERVES THE RIGHT TO SUBSTITUTE OEM PARTS IN PLACE OF THERMACUT PARTS. VALID FROM SEPTEMBER 2024 • PREVIOUS VERSION IS NO LONGER VALID. • © COPYRIGHT 2024 BY THERMACUT® CZECH REPUBLIC. ALL RIGHTS RESERVED.

**THERMACUT® REPLACEMENT PARTS SUITABLE FOR
ESAB®/L-TEC®
PT-36™**



PRODUCT BROCHURE WITH DETAILS AT
WWW.THERMACUT.COM

Item	Part No.	Ref. No.	Description	Std. Pkg.	Item	Part No.	Ref. No.	Description	Std. Pkg.
1.	T-10128	37081	Shield Retainer	1	17.	T-11119	0558002530	Gas Swirl Baffle, 8 × 0.047, 360-450A, CCW	1
2.	T-12231	0558009425	Micro Shield 2.5mm 30-60A MS	10	18.	T-11942	37073	Screw, Contact Ring	1
	T-10463	0558007624	Shield Cup 2.4mm 45-55A	1	19.	T-11863	0558003858	Cont. Ring with 2pcs. Screws 37073 (=37071)	1
	T-10333	0558006130	Shield Cup 3.0mm 35-50A	1	20.	T-12040	T-12040	Exchangeable Insulator Kit	1
	T-10332	0558006141	Shield Cup 4.1mm 70-280A	1	21.	PT-13160	0558001825-11	Plastic Screw	1
	T-10334	0558006166	Shield Cup 6.6mm 290-450A	1	22.	PT-13159	0558001825-10	Screw	1
	T-10335	0558006199	Shield Cup 9.9mm 300-600A	1	23.	PT-12123	0558001825-8	Insulator Body	1
3.	T-2269	21944	Diffuser 100-600A	1	24.	T-11208	0558003804	Torch Body PT-36™	1
	T-10331	22496	Diffuser 100-600A, CCW	1	25.	N-20426	93750010	Hex Key Wrench for Contact Ring	1
4.	T-2268	21796	Gas Diffuser 50A	1	OD 26.	T-11665	0558003918 OEM	Electrode Holder Wrench	1
5.	T-10129	37082	Nozzle Retaining Cap, Standard	1	27.	KT-1452	0558006745	PT-36™ Mach. Torch with Leads 1.3m	1
6.	T-12229	0558009406	Micro Nozzle 0.6mm 30A MS/SS/AL	10		KT-1453	0558006746	PT-36™ Mach. Torch with Leads 1.8m	1
	T-12230	0558009410	Micro Nozzle 1.0mm 60A MS/SS/AL	10		KT-1454	0558006747	PT-36™ Mach. Torch with Leads 3.7m	1
	T-10875	0558008010	Nozzle 1.0mm	1		KT-1455	0558006749	PT-36™ Mach. Torch with Leads 4.6m	1
	T-10336	0558006010	Nozzle 1.0mm 45/50A MS/SS/AL	1		KT-1456	0558006750	PT-36™ Mach. Torch with Leads 5.2m	1
	T-10337	0558006014	Nozzle 1.4mm 100A MS/AL (70/130A SS)	1		KT-1457	0558006779	PT-36™ Mach. Torch with Leads 6.1m	1
	T-10970	0558006018	Nozzle 1.8mm 100/130A MS (100A SS/AL)	1		KT-1458	0558006751	PT-36™ Mach. Torch with Leads 7.6m	1
	T-10338	0558006020	Nozzle 2.0mm 150/200A MS/AL (130/150A SS)	1	28.	KT-1460	0558007031	PT-36™ Cable Leads 1.3m	1
	T-10339	0558006023	Nozzle 2.3mm 200/280A MS (200A SS), (200/260A AL)	1		KT-1461	0558007032	PT-36™ Cable Leads 1.8m	1
	T-10340	0558006025	Nozzle 2.5mm 280/290A MS (260A SS)	1		KT-1462	0558007034	PT-36™ Cable Leads 3.7m	1
	T-10443	0558006030	Nozzle 3.0mm 325/360A MS (360A SS/AL)	1		KT-1463	0558007036	PT-36™ Cable Leads 4.6m	1
	T-10341	0558006036	Nozzle 3.6mm 400A MS (450A SS)	1		KT-1464	0558007037	PT-36™ Cable Leads 5.2m	1
OD	T-10292	0558006041	Nozzle 4.1mm 600A SS/AL	1		KT-1465	0558007038	PT-36™ Cable Leads 6.1m	1
7.	T-12228	0558009400-PRO	Micro Electrode 30-60A MS/SS/AL	5		KT-1466	0558007039	PT-36™ Cable Leads 7.6m	1
	T-11910	0558003928-UR	Electrode, N ₂ /H35	5		KT-1522	0558007035	PT-36™ Cable Leads 4.3m, Bevel	1
8.	T-11303	T-11303-PRO	Electrode 50-250A, Silver PRO	5	29.	KT-1478	0558003849	PT-36™ Mach. Torch with Leads 1.4m	1
9.	T-11290*	0558003914-PRO	Electrode 100-450A, O ₂ , Silver PRO	5		KT-1479	0558003850	PT-36™ Mach. Torch with Leads 1.8m	1
10.	T-11994	0558012000-PRO	Electrode 100-450A, O ₂ , Silver PRO	5		KT-1480	0558003852	PT-36™ Mach. Torch with Leads 3.7m	1
11.	T-11209**	0558003914-AG	Electrode, Standard, O ₂	5		KT-1481	0558003853	PT-36™ Mach. Torch with Leads 4.6m	1
12.	T-11319	0558003924-UR	Electrode Holder	1		KT-1482	0558003854	PT-36™ Mach. Torch with Leads 5.2m	1
13.	T-10693	0558005457 OEM	Gas Swirl Baffle, 4 × 0.022, 35-70A	5		KT-1483	0558003856	PT-36™ Mach. Torch with Leads 7.6m	1
14.	T-4607	0558002534	Gas Swirl Baffle, 4 × 0.032, 100-280A, CCW	1	30.	Cable Leads are available on request, because of more possible types of fittings.			
15.	T-4606	0558002533	Gas Swirl Baffle, 4 × 0.032, 100-280A	1	31.	Coolant Liquid. Details on the Accessories page.			
16.	T-4636	0558001625	Gas Swirl Baffle, 8 × 0.047, 300-600A	1	32.	Consumable Case. Details on the Accessories page.			

* A UNIQUE DESIGN WHICH ENHANCES PERFORMANCE AND DIFFERS FROM OEM DESIGNS

** AVAILABILITY ON REQUEST

OD ON DEMAND – WE DO NOT KEEP THESE PARTS IN STOCK, COST IS SET ACCORDING TO THE ORDERED QUANTITY, DELIVERY TIME MAY DIFFER FROM STANDARD PRODUCTS.

CCW COUNTER CLOCK WISE GAS SWIRLING, USE OF CCW PARTS WILL MAKE CUT ANGLE ON THE OPPOSITE SIDE, THAN WITH STANDARD CLOCK WISE (CW) SWIRLING PARTS.

-PRO SILVER PRO TECHNOLOGY INCREASES ELECTRODE LIFETIME SIGNIFICANTLY COMPARED TO STANDARD COPPER ELECTRODES

THERMACUT®, FHT-EX® AND EX-TRAFIRE® ARE REGISTERED TRADEMARKS OF THERMACUT, K. S. AND MAY BE REGISTERED IN CZECH REPUBLIC AND/OR OTHER COUNTRIES. ALL OTHER TRADEMARKS ARE PROPERTIES OF THEIR RESPECTIVE OWNERS. THERMACUT IS NO WAY AFFILIATED WITH ESAB®/L-TEC®. MOST THERMACUT PARTS ARE MADE FOR OR BY AN IBG COMPANY. PARTS INDICATED WITH A OEM ARE ORIGINAL PARTS MANUFACTURED BY THE ABOVE NAMED MANUFACTURER AND ARE BEING RESOLD BY THERMACUT. THERMACUT RESERVES THE RIGHT TO SUBSTITUTE OEM PARTS IN PLACE OF THERMACUT PARTS. VALID FROM SEPTEMBER 2024 • PREVIOUS VERSION IS NO LONGER VALID. • © COPYRIGHT 2024 BY THERMACUT® CZECH REPUBLIC. ALL RIGHTS RESERVED.

**THERMACUT® REPLACEMENT PARTS SUITABLE FOR
ESAB®/L-TEC®
PT-600™**

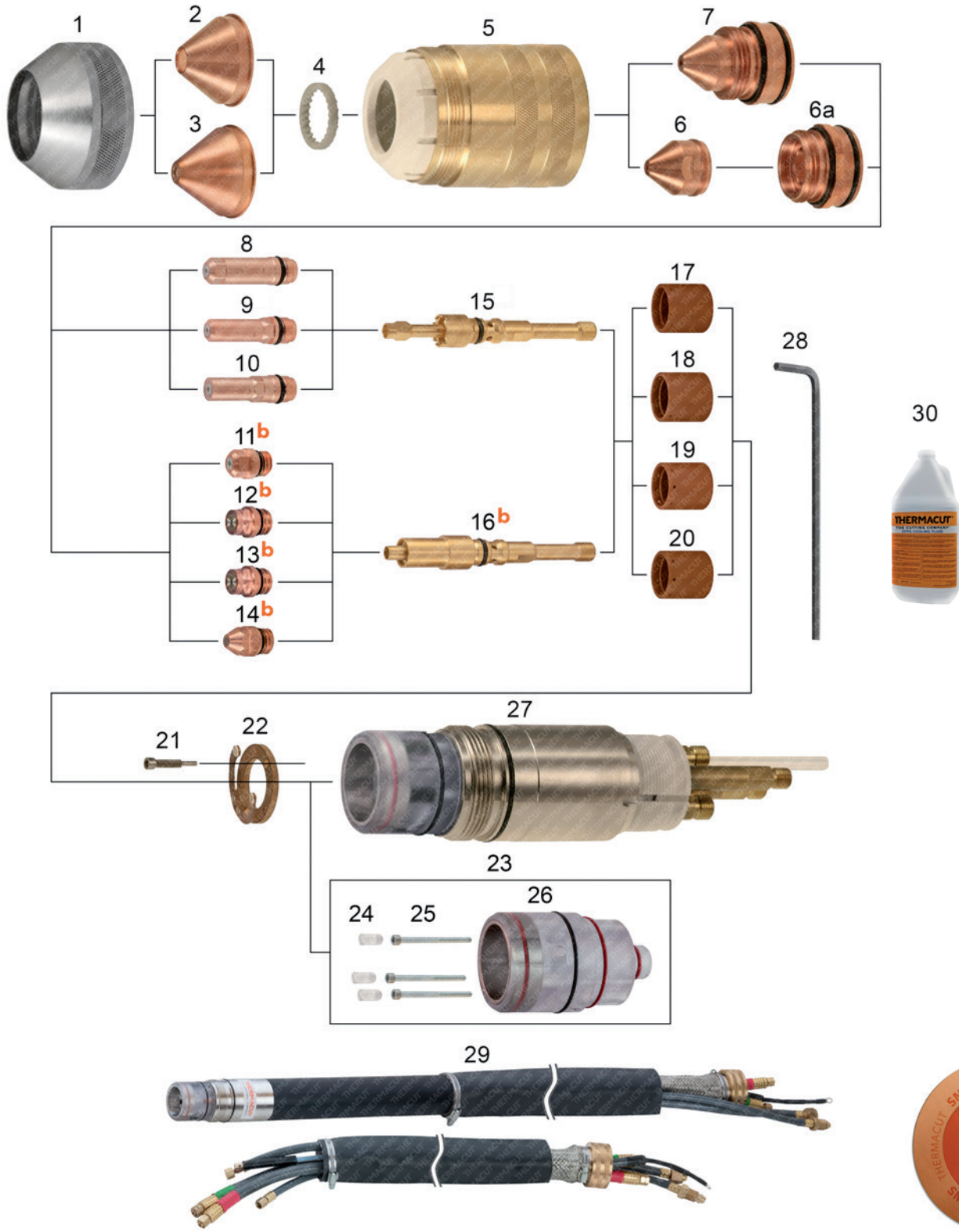

THERMACUT®, FHT-EX® AND EX-TRAFIRE® ARE REGISTERED TRADEMARKS OF THERMACUT, K. S. AND MAY BE REGISTERED IN CZECH REPUBLIC AND/OR OTHER COUNTRIES. ALL OTHER TRADEMARKS ARE PROPERTIES OF THEIR RESPECTIVE OWNERS. THERMACUT IS NO WAY AFFILIATED WITH ESAB®/L-TEC®. MOST THERMACUT PARTS ARE MADE FOR OR BY AN IBG COMPANY. PARTS INDICATED WITH A OEM ARE ORIGINAL PARTS MANUFACTURED BY THE ABOVE NAMED MANUFACTURER AND ARE BEING RESOLD BY THERMACUT. THERMACUT RESERVES THE RIGHT TO SUBSTITUTE OEM PARTS IN PLACE OF THERMACUT PARTS. VALID FROM SEPTEMBER 2024 • PREVIOUS VERSION IS NO LONGER VALID. • © COPYRIGHT 2024 BY THERMACUT® CZECH REPUBLIC. ALL RIGHTS RESERVED.

**THERMACUT® REPLACEMENT PARTS SUITABLE FOR
ESAB®/L-TEC®
PT-600™**



PRODUCT BROCHURE WITH DETAILS AT
WWW.THERMACUT.COM

Item	Part No.	Ref. No.	Description	Std. Pkg.	Item	Part No.	Ref. No.	Description	Std. Pkg.
1.	T-10128	37081	Shield Retainer	1	b 13.	T-11994	0558012000-PRO	Electrode 100-450A, O ₂ , Silver PRO	5
2.	T-2266	21802	Shield 100-250A	1	b 14.	T-11910	0558003928-UR	Electrode, N ₂ /H35	5
	T-2267	21945	Shield 360A	1	15.	T-11201	0558001621	Electrode Holder	1
3.	T-10124	0558004678	Precision Shield 110-200A		b 16.	T-11210	T-11210	Electrode Holder	1
4.	T-2269	21944	Diffuser 100-600A	1	17.	T-4606	0558002533	Gas Swirl Baffle, 4 hole × 0.032, CW	1
	T-10331	22496	Diffuser 100-600A, CCW	1	18.	T-4607	0558002534	Gas Swirl Baffle, 4 hole × 0.032, CCW	1
NS	T-2268	21796	Gas Diffuser 50A	1	19.	T-4636	0558001625	Gas Swirl Baffle, 8 hole × 0.047, CW	1
5.	T-10129	37082	Nozzle Retaining Cap	1	20.	T-11119	0558002530	Gas Swirl Baffle, 8 Hole × 0.047, CCW	1
6.	T-1720	22026	Nozzle Tip 50A	5	21.	T-11942	37073	Screw	1
	T-1717	22029	Nozzle Tip 100A	5	22.	T-11863	0558003858	Cont. Ring with 2pcs. Screws 37073 (=37071)	1
	T-1718	22030	Nozzle Tip 150A	5	23.	T-12040	T-12040	Exchangeable Insulator Kit	1
	T-1719	22031	Nozzle Tip 200A	5	24.	PT-13160	0558001825-11	Plastic Screw	1
6a.	T-1721	22027	Nozzle Base 50A	1	25.	PT-13159	0558001825-10	Screw	1
	T-1722	22028	Nozzle Base 100-250A	1	26.	PT-12123	0558001825-8	Insulator Body	1
7.	T-5332	0558001882	Nozzle 100A	1	27.	T-10283	0558001825	Torch Body	1
	T-5333	0558001883	Nozzle 150A	1	OD NS	T-11202	T-11202	Electrode Holder Wrench	1
	T-5334	0558001884	Nozzle 200A	1	NS	KT-1178	996248	PT-600™ Hose, power, 1.8m	1
	T-5330	0558001623	Nozzle 250A	1	NS	KT-1176	34360	PT-600™ Hose, plas., 1.8m	1
	T-5335	0558001885	Nozzle 360A	1	NS	KT-1189	33209	PT-600™ Hose, power, 4.6m	1
	T-5336	0558001886	Nozzle 400A	1	NS	KT-1330	33211	PT-600™ Hose, power, 7.6m	1
OD	T-5337	0558001887	Nozzle 600A	1	NS	KT-1177	37357	PT-600™ Cable, pilot, 2m	1
8.	T-11239	0558001624-PRO	Electrode 250A, Silver PRO	5	28.	N-20426	93750010	Hex Key Wrench for Contact Ring	1
OD 9.	T-11240	T-11240-PRO	Electrode 260/400A, Silver PRO	5	29.	Cable Leads are available on request, because of more possible types of fittings.			
10.	T-11238	0558002516-PRO	Electrode 360/400A, Silver PRO	5	30.	Coolant Liquid. Details on the Accessories page.			
b 11.	T-11303	T-11303-PRO	Electrode 50-250A, Silver PRO	5					
b 12.	T-11290*	0558003914-PRO	Electrode 100-450A, O ₂ , Silver PRO	5					

b MUST BE USED ONLY AS A SET OF ELECTRODE HOLDER T-11210 AND T-11303-PRO, 0558003914-PRO, 0558012000-PRO, 0558003928-UR ELECTRODES.

OD ON DEMAND – WE DO NOT KEEP THESE PARTS IN STOCK, COST IS SET ACCORDING TO THE ORDERED QUANTITY, DELIVERY TIME MAY DIFFER FROM STANDARD PRODUCTS.

***** A UNIQUE DESIGN WHICH ENHANCES PERFORMANCE AND DIFFERS FROM OEM DESIGNS

CCW COUNTER CLOCK WISE GAS SWIRLING, USE OF CCW PARTS WILL MAKE CUT ANGLE ON THE OPPOSITE SIDE, THAN WITH STANDARD CLOCK WISE (CW) SWIRLING PARTS.

NS NOT SHOWN IN THE PICTURE

-PRO TECHNOLOGY OF SILVER INSERTED COPPER ELECTRODE BODY, WHICH SIGNIFICANTLY DECREASES ELECTRODE COSTS WITH SIMILAR WORK PERFORMANCE COMPARED TO FULL SILVER ELECTRODES.

SMART SOLUTION - DESIGN IMPROVEMENTS THAT BRINGS ADDED VALUE SUCH AS IMPROVED LIFETIME OF CONSUMABLES, EXCELLENT CUT QUALITY, SPEED OR BETTER COST EFFECTIVENESS OF YOUR SYSTEM.

THERMACUT®, FHT-EX® AND EX-TRAFIRE® ARE REGISTERED TRADEMARKS OF THERMACUT, K. S. AND MAY BE REGISTERED IN CZECH REPUBLIC AND/OR OTHER COUNTRIES. ALL OTHER TRADEMARKS ARE PROPERTIES OF THEIR RESPECTIVE OWNERS. THERMACUT IS NO WAY AFFILIATED WITH ESAB®/L-TEC®. MOST THERMACUT PARTS ARE MADE FOR OR BY AN IBG COMPANY. PARTS INDICATED WITH A OEM ARE ORIGINAL PARTS MANUFACTURED BY THE ABOVE NAMED MANUFACTURER AND ARE BEING RESOLD BY THERMACUT. THERMACUT RESERVES THE RIGHT TO SUBSTITUTE OEM PARTS IN PLACE OF THERMACUT PARTS. VALID FROM SEPTEMBER 2024 • PREVIOUS VERSION IS NO LONGER VALID. • © COPYRIGHT 2024 BY THERMACUT® CZECH REPUBLIC. ALL RIGHTS RESERVED.

**THERMACUT® REPLACEMENT PARTS SUITABLE FOR
Hypertherm®
MAX®40cs/MAX®42/MAX®43 | PAC®120/PAC®125T**

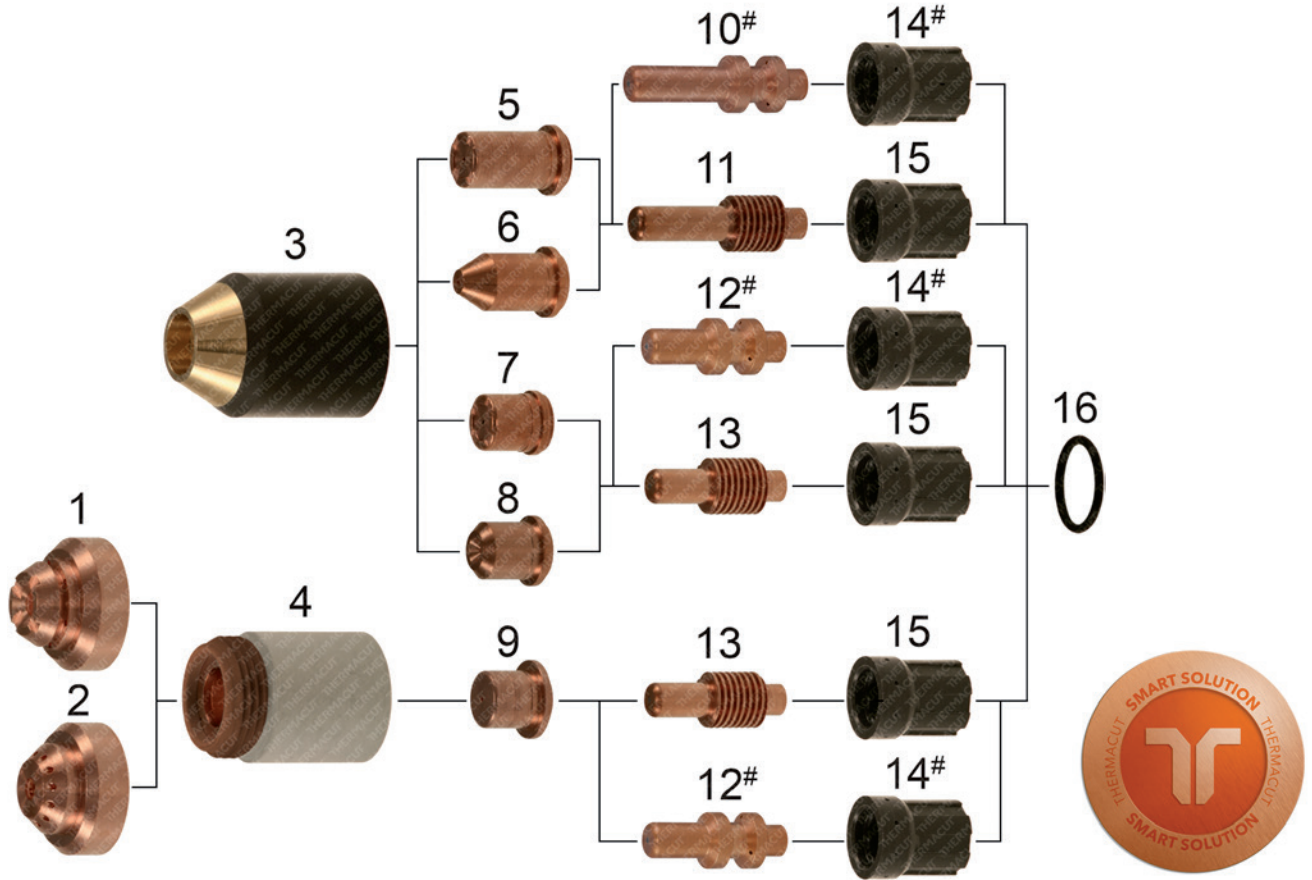

Item	Part No.	Ref. No.	Description	Std. Pkg.	Item	Part No.	Ref. No.	Description	Std. Pkg.
1.	T-9824	120601-UR	Shield, Hand	1	a 10.	T-4451	120574-UR	Electrode, Extended, Long Life	5
2.	T-9825	120602-UR	Shield, Machine	1	11.	T-2298	120574	Electrode, Extended	5
3.	T-9580	020930	Retaining Cap	1	a 12.	T-4450	120573-UR	Electrode, Long Life	5
4.	T-12045	120600	Retaining Cap	1	13.	T-3419	120573	Electrode	5
5.	T-0089	020546	Nozzle, Extended	10	aOD 14.	T-4452	020361-UR	Swirl Ring	2
6.	T-0093	120023	Nozzle, Pipe Saddle	5	15.	T-0029	020361	Swirl Ring	2
7.	T-0027	020350	Nozzle, 40A	10	OD 16.	T-0038	044016	O-Ring	10
	T-0028	020395	Nozzle	10	NS	KT-1405	128925	RT60M™ Cable Leads 15.2m (50') with CC	1
OD 8.	T-0094	020539	Nozzle, Gouging	10	NS	KT-1406	083218-UR	RT60M™ Machine Torch with Leads 15.2m (50') with CC	1
9.	T-3420	120438	Nozzle	10					

* FULLY INTERCHANGEABLE AND COMPATIBLE WITH ORIGINAL PARTS, BUT DIFFERS FROM ORIGINAL DESIGN

a MUST BE USED ONLY AS THE SET OF ELECTRODE & SWIRL RING LIKE SHOWN IN THE PICTURE (-UR DESIGN VERSION OR OEM VERSION), SET OFFERS LIFETIME LONGER UP TO 50%.

OD ON DEMAND – WE DO NOT KEEP THESE PARTS IN STOCK, COST IS SET ACCORDING TO THE ORDERED QUANTITY, DELIVERY TIME MAY DIFFER FROM STANDARD PRODUCTS.

NS NOT SHOWN IN THE PICTURE

SMART SOLUTION – DESIGN IMPROVEMENTS THAT BRINGS ADDED VALUE SUCH AS IMPROVED LIFETIME OF CONSUMABLES, EXCELLENT CUT QUALITY, SPEED OR BETTER COST EFFECTIVENESS OF YOUR SYSTEM

THERMACUT®, FHT-EX® AND EX-TRAFIRE® ARE REGISTERED TRADEMARKS OF THERMACUT, K. S. AND MAY BE REGISTERED IN CZECH REPUBLIC AND/OR OTHER COUNTRIES. ALL OTHER TRADEMARKS ARE PROPERTIES OF THEIR RESPECTIVE OWNERS. THERMACUT IS NO WAY AFFILIATED WITH HYPERTHERM®. MOST THERMACUT PARTS ARE MADE FOR OR BY AN IBG COMPANY. PARTS INDICATED WITH A OEM ARE ORIGINAL PARTS MANUFACTURED BY THE ABOVE NAMED MANUFACTURER AND ARE BEING RESOLD BY THERMACUT. THERMACUT RESERVES THE RIGHT TO SUBSTITUTE OEM PARTS IN PLACE OF THERMACUT PARTS. VALID FROM SEPTEMBER 2024 • PREVIOUS VERSION IS NO LONGER VALID. • © COPYRIGHT 2024 BY THERMACUT® CZECH REPUBLIC. ALL RIGHTS RESERVED.

THERMACUT® REPLACEMENT PARTS SUITABLE FOR
Hypertherm®
MAX®40 | PAC®140/M

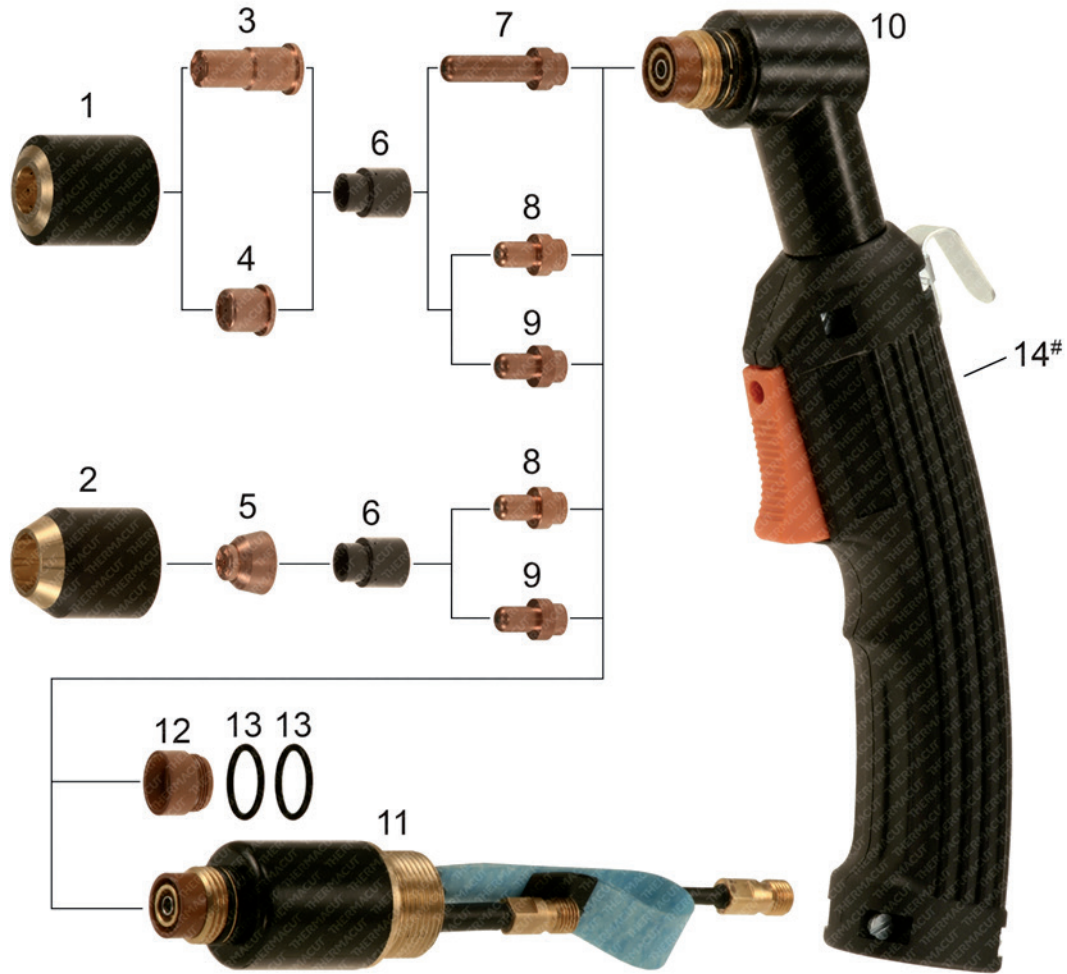

Item	Part No.	Ref. No.	Description	Std. Pkg.	Item	Part No.	Ref. No.	Description	Std. Pkg.
1.	T-0043	020104	Retaining Cap, Standard	1	9,11.	T-0055	020122	PAC®140 Hand Torch + Handle	1
2.	T-0044	020200	Retaining Cap, Tapered	1	10.	T-0056	020114	PAC®140/M Machine Torch	1
3.	T-0050	020466	Nozzle, Extended	10	#11.	T-1040#	9-5636-1	Handle	1
4.	T-0045	020115	Nozzle 40A	10	NS	KT-1229	K.PAC140H.5M	PAC®140/H Hand Torch with Lead 5m (16')	1
	T-0046	020102	Nozzle 40A (HT®40)	10	NS	KT-1210	057112	PAC®140/H Hand Torch with Lead 7.6m (25')	1
5.	T-0048	020197	Nozzle 40A, Tapered	10	NS	KT-1261	057113	PAC®140/H Hand Torch with Lead 15.2m (50')	1
NS	T-0047	020131	Nozzle, Pipe Saddle (HT®40)	10	NS	KT-1084	028290	PAC®140/M Cable Leads, Mach. 15.2m (50')	1
6.	T-0051	020101	Swirl Ring	2				Different types of cable leads available on request	
7.	T-0054	020467	Electrode, Extended	5	12.			Not available any more – OEM only.	
8.	T-0052	020103	Electrode, Air	10					

ONLY FOR THERMACUT® TORCH DESIGN

NS NOT SHOWN IN THE PICTURE

MAX®40 AND HT®40 PARTS ARE FULLY INTERCHANGEABLE IN CASE OF NEED.

THERMACUT®, FHT-EX® AND EX-TRAFIRE® ARE REGISTERED TRADEMARKS OF THERMACUT, K. S. AND MAY BE REGISTERED IN CZECH REPUBLIC AND/OR OTHER COUNTRIES. ALL OTHER TRADEMARKS ARE PROPERTIES OF THEIR RESPECTIVE OWNERS. THERMACUT IS NO WAY AFFILIATED WITH HYPERTHERM®. MOST THERMACUT PARTS ARE MADE FOR OR BY AN IBG COMPANY. PARTS INDICATED WITH A OEM ARE ORIGINAL PARTS MANUFACTURED BY THE ABOVE NAMED MANUFACTURER AND ARE BEING RESOLD BY THERMACUT. THERMACUT RESERVES THE RIGHT TO SUBSTITUTE OEM PARTS IN PLACE OF THERMACUT PARTS. VALID FROM SEPTEMBER 2024 • PREVIOUS VERSION IS NO LONGER VALID. • © COPYRIGHT 2024 BY THERMACUT® CZECH REPUBLIC. ALL RIGHTS RESERVED.

THERMACUT® REPLACEMENT PARTS SUITABLE FOR
Hypertherm®
HT®40 | PAC®140/M

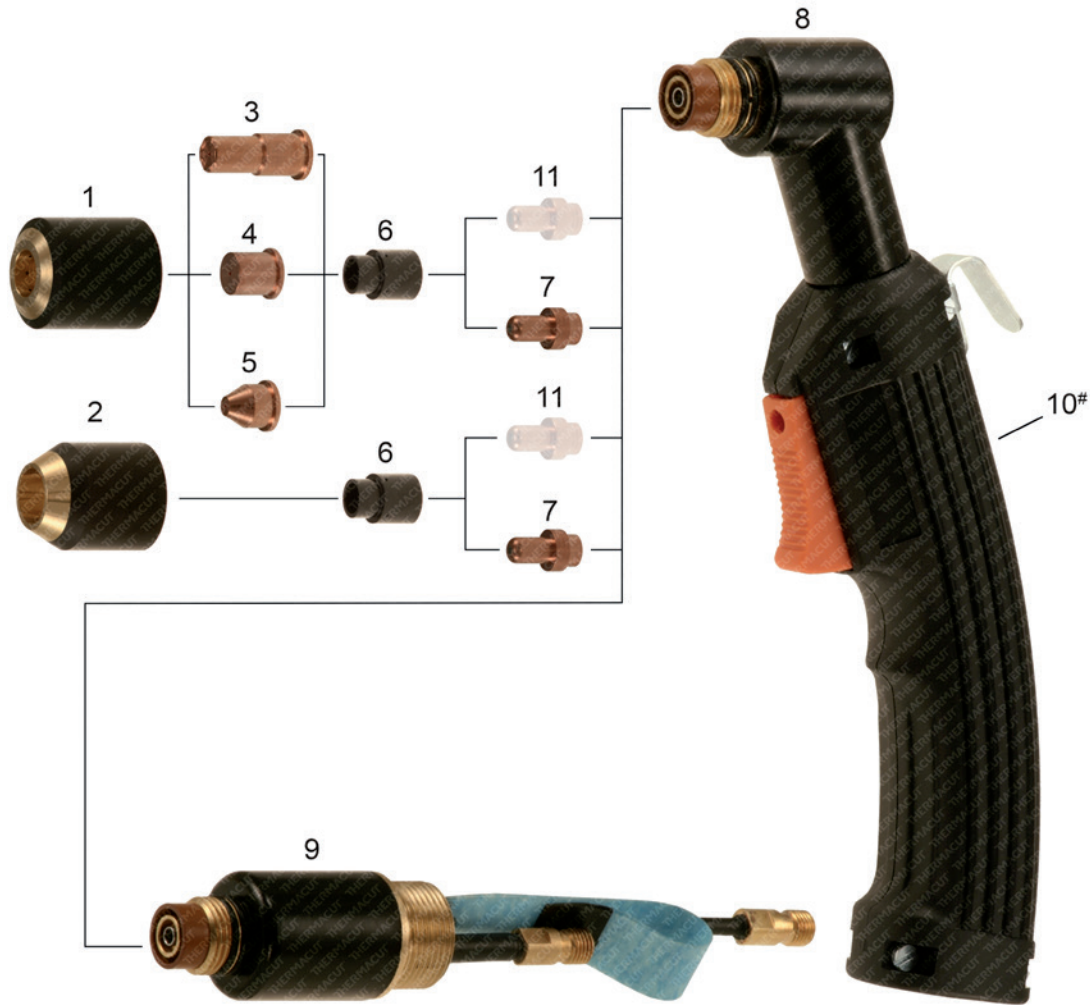

Item	Part No.	Ref. No.	Description	Std. Pkg.	Item	Part No.	Ref. No.	Description	Std. Pkg.
1.	T-0043	020104	Retaining Cap, Standard	1	9.	T-0056	020114	PAC®140/M Machine Torch	1
2.	T-0044	020200	Retaining Cap, Tapered	1	#10.	T-1040#	9-5636-1	Handle	1
3.	T-0050	020466	Nozzle, Extended	10	NS	KT-1229	K.PAC140H.5M	PAC®140/H Hand Torch with Lead 5m (16')	1
4.	T-0046	020102	Nozzle 40A	10	NS	KT-1210	057112	PAC®140/H Hand Torch with Lead 7.6m (25')	1
5.	T-0047	020131	Nozzle, Pipe Saddle	10	NS	KT-1261	057113	PAC®140/H Hand Torch with Lead 15.2m (50')	1
6.	T-0051	020101	Swirl Ring	2	NS	KT-1084	028290	PAC®140/M Cable Leads, Mach. 15.2m (50')	1
7.	T-0052	020103	Electrode, Air	10	11.	Not available any more – OEM only.			
8.,10.	T-0055	020122	PAC®140 Hand Torch + Handle	1	Different types of cable leads available on request				

ONLY FOR THERMACUT® TORCH DESIGN

NS NOT SHOWN IN THE PICTURE

MAX®40 AND HT®40 PARTS ARE FULLY INTERCHANGEABLE IN CASE OF NEED.

THERMACUT®, FHT-EX® AND EX-TRAFIRE® ARE REGISTERED TRADEMARKS OF THERMACUT, K. S. AND MAY BE REGISTERED IN CZECH REPUBLIC AND/OR OTHER COUNTRIES. ALL OTHER TRADEMARKS ARE PROPERTIES OF THEIR RESPECTIVE OWNERS. THERMACUT IS NO WAY AFFILIATED WITH HYPERTHERM®. MOST THERMACUT PARTS ARE MADE FOR OR BY AN IBG COMPANY. PARTS INDICATED WITH A OEM ARE ORIGINAL PARTS MANUFACTURED BY THE ABOVE NAMED MANUFACTURER AND ARE BEING RESOLD BY THERMACUT. THERMACUT RESERVES THE RIGHT TO SUBSTITUTE OEM PARTS IN PLACE OF THERMACUT PARTS. VALID FROM SEPTEMBER 2024 • PREVIOUS VERSION IS NO LONGER VALID. • © COPYRIGHT 2024 BY THERMACUT® CZECH REPUBLIC. ALL RIGHTS RESERVED.

THERMACUT® REPLACEMENT PARTS SUITABLE FOR
Hypertherm®
MAX®70/MAX®80/MAX®100 | PAC®130/M

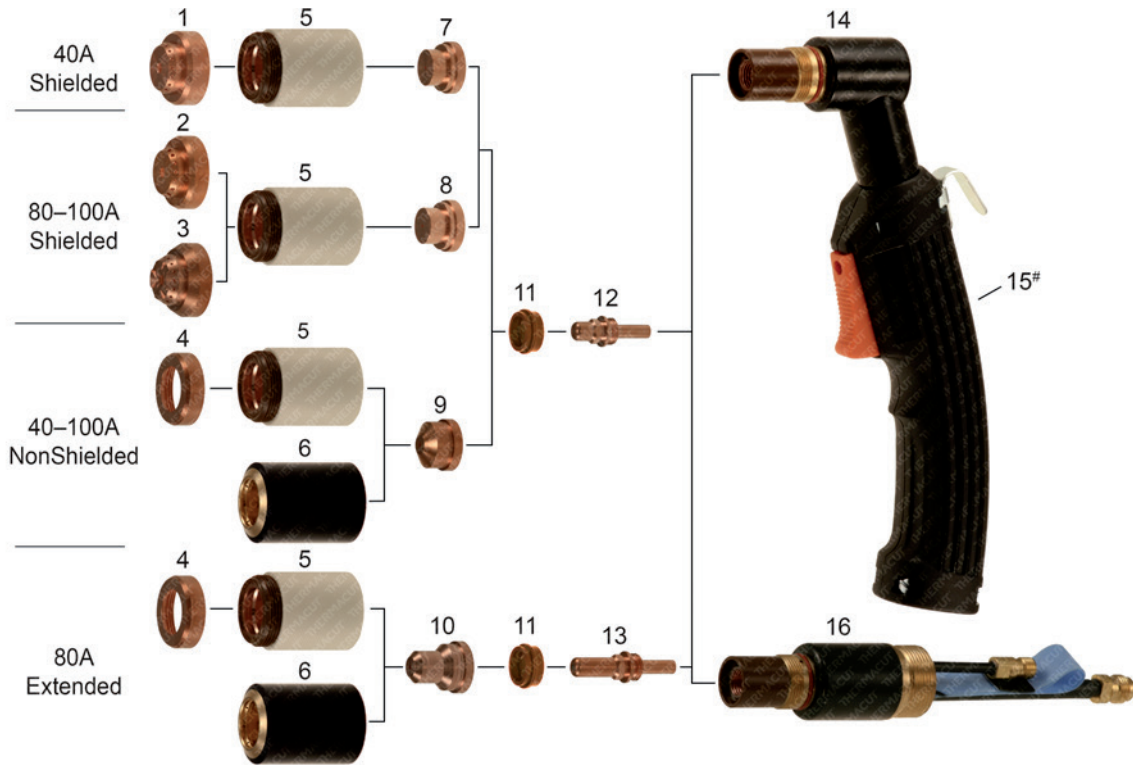

Item	Part No.	Ref. No.	Description	Std. Pkg.	Item	Part No.	Ref. No.	Description	Std. Pkg.
1.	T-1041	020492	Shield Mach. 40A - MAX®100, 60A - MAX®100D	1	10.	T-0100	020563	Nozzle 80A, Extended	5
2.	T-0071	020334	Shield 100A, Machine	1	OD NS	T-0064	020339	Nozzle 100A, Gouging	5
3.	T-0072	020335	Shield 100A, Hand	1	11.	T-0065	020194	Swirl Ring	2
4.	T-0070	020333	Deflector	1	12.	T-8128	120433	Electrode 80A, 100A	5
5.	T-4609	020336	Retaining Cap	1		T-0066	020191	Electrode 80A, 100A	5
6.	T-0058	020184	Retaining Cap	1		T-0067	020193	Electrode 40A, 80A, 100A	5
7.	T-0099	020396	Nozzle 40A, Shielded	5	13.	T-0098	020564	Electrode, Extended	5
8.	T-0062	020397	Nozzle 80A, Shielded	5	14.,15.	T-0068	020189	PAC®130, Hand Torch + Handle	1
	T-0063	020337	Nozzle 100A, Shielded	5	#15.	T-1040#	9-5636-1	Handle	1
9.	T-0059	020203	Nozzle 40A, NonShielded	5	16.	T-0069	020201	PAC®130/M, Machine Torch Main Body	1
	T-0060	020345	Nozzle 80A, NonShielded	5	Different types of cable leads available on request				
	T-0061	020195	Nozzle 100A, NonShielded	5					

OD ON DEMAND – WE DO NOT KEEP THESE PARTS IN STOCK, COST IS SET ACCORDING TO THE ORDERED QUANTITY, DELIVERY TIME MAY DIFFER FROM STANDARD PRODUCTS.

ONLY FOR THERMACUT® TORCH DESIGN

NS NOT SHOWN IN THE PICTURE

CC CENTRAL CONNECTOR

W/ WITH

THERMACUT®, FHT-EX® AND EX-TRAFIRE® ARE REGISTERED TRADEMARKS OF THERMACUT, K. S. AND MAY BE REGISTERED IN CZECH REPUBLIC AND/OR OTHER COUNTRIES. ALL OTHER TRADEMARKS ARE PROPERTIES OF THEIR RESPECTIVE OWNERS. THERMACUT IS NO WAY AFFILIATED WITH HYPERTHERM®. MOST THERMACUT PARTS ARE MADE FOR OR BY AN IBG COMPANY. PARTS INDICATED WITH A OEM ARE ORIGINAL PARTS MANUFACTURED BY THE ABOVE NAMED MANUFACTURER AND ARE BEING RESOLD BY THERMACUT. THERMACUT RESERVES THE RIGHT TO SUBSTITUTE OEM PARTS IN PLACE OF THERMACUT PARTS. VALID FROM SEPTEMBER 2024 • PREVIOUS VERSION IS NO LONGER VALID. • © COPYRIGHT 2024 BY THERMACUT® CZECH REPUBLIC. ALL RIGHTS RESERVED.

THERMACUT® REPLACEMENT PARTS SUITABLE FOR
Hypertherm®
POWERMAX® 600 | PAC® 123T/M

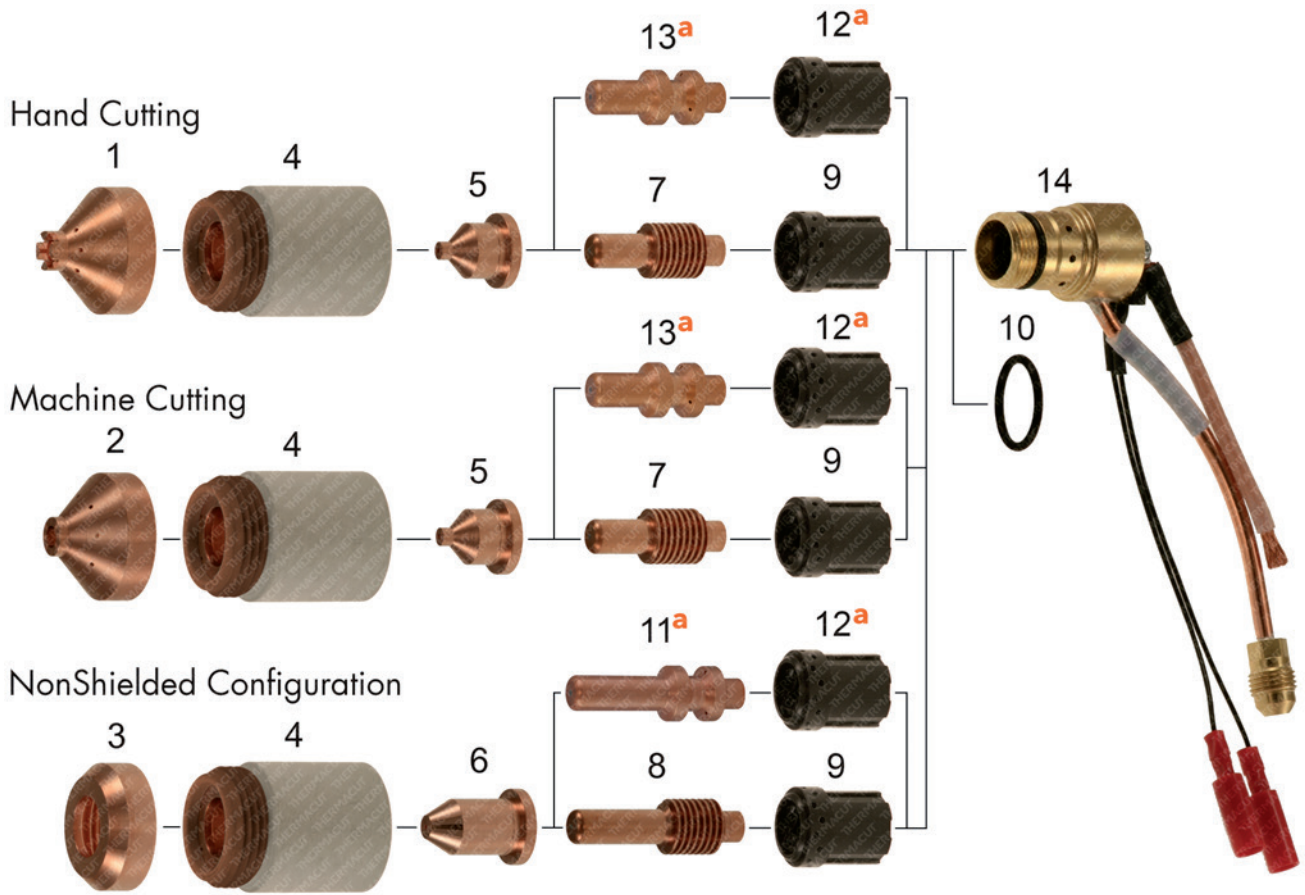

THERMACUT®, FHT-EX® AND EX-TRAFIRE® ARE REGISTERED TRADEMARKS OF THERMACUT, K. S. AND MAY BE REGISTERED IN CZECH REPUBLIC AND/OR OTHER COUNTRIES. ALL OTHER TRADEMARKS ARE PROPERTIES OF THEIR RESPECTIVE OWNERS. THERMACUT IS NO WAY AFFILIATED WITH HYPERTHERM®. MOST THERMACUT PARTS ARE MADE FOR OR BY AN IBG COMPANY. PARTS INDICATED WITH A OEM ARE ORIGINAL PARTS MANUFACTURED BY THE ABOVE NAMED MANUFACTURER AND ARE BEING RESOLD BY THERMACUT. THERMACUT RESERVES THE RIGHT TO SUBSTITUTE OEM PARTS IN PLACE OF THERMACUT PARTS. VALID FROM SEPTEMBER 2024 • PREVIOUS VERSION IS NO LONGER VALID. • © COPYRIGHT 2024 BY THERMACUT® CZECH REPUBLIC. ALL RIGHTS RESERVED.

THERMACUT® REPLACEMENT PARTS SUITABLE FOR
Hypertherm®
POWERMAX® 600 | PAC® 123T/M

Item	Part No.	Ref. No.	Description	Std. Pkg.	Item	Part No.	Ref. No.	Description	Std. Pkg.
1.	T-9827	120828-UR	Shield 40A, Hand	1	a 13.	T-4450	120573-UR	Electrode, Long Life	5
2.	T-10727	120827-UR	Shield 40A, Machine	1	14.	T-10269	120570	Torch Main Body with Safety Switch	1
3.	T-1564	120303	Deflector	1	OD NS	KT-1334	129476	PAC®123T Cable Leads, Hand 7.6m (25')	1
4.	T-12045	120600	Retaining Cap	1		T-4559	129600	Torch Leads, 25'	1
5.	T-2847	120826	Nozzle 40A	5			129601	Torch Leads, 50'	1
6.	T-3418	120606	Nozzle 35A, Extended	10			086023	Torch Assy, Hand 25'	1
7.	T-3419	120573	Electrode	5		T-4590	086024	Torch Assy, Hand 25'	1
8.	T-2298	120574	Electrode, Extended	5		T-10609	086025	Torch Assy, Hand 50'	1
9.	T-2230	120576	Swirl Ring	2	Different types of cable leads available on request				
OD 10.	T-0038	044016	O-Ring	10					
a 11.	T-4451	120574-UR	Electrode, Extended, Long Life	5					
a 12.	T-4453	120576-UR	Swirl Ring, Long Life	2					

* FULLY INTERCHANGEABLE AND COMPATIBLE WITH ORIGINAL PARTS, BUT DIFFERS FROM ORIGINAL DESIGN

a MUST BE USED ONLY AS THE SET OF ELECTRODE & SWIRL RING LIKE SHOWN IN THE PICTURE (-UR DESIGN VERSION OR OEM VERSION), SET OFFERS LIFETIME LONGER UP TO 50%

OD ON DEMAND – WE DO NOT KEEP THESE PARTS IN STOCK, COST IS SET ACCORDING TO THE ORDERED QUANTITY, DELIVERY TIME MAY DIFFER FROM STANDARD PRODUCTS.

NS NOT SHOWN IN THE PICTURE

SMART SOLUTION – DESIGN IMPROVEMENTS THAT BRINGS ADDED VALUE SUCH AS IMPROVED LIFETIME OF CONSUMABLES, EXCELLENT CUT QUALITY, SPEED OR BETTER COST EFFECTIVENESS OF YOUR SYSTEM.

THERMACUT®, FHT-EX® AND EX-TRAFIRE® ARE REGISTERED TRADEMARKS OF THERMACUT, K. S. AND MAY BE REGISTERED IN CZECH REPUBLIC AND/OR OTHER COUNTRIES. ALL OTHER TRADEMARKS ARE PROPERTIES OF THEIR RESPECTIVE OWNERS. THERMACUT IS NO WAY AFFILIATED WITH HYPERTHERM®. MOST THERMACUT PARTS ARE MADE FOR OR BY AN IBG COMPANY. PARTS INDICATED WITH A OEM ARE ORIGINAL PARTS MANUFACTURED BY THE ABOVE NAMED MANUFACTURER AND ARE BEING RESOLD BY THERMACUT. THERMACUT RESERVES THE RIGHT TO SUBSTITUTE OEM PARTS IN PLACE OF THERMACUT PARTS. VALID FROM SEPTEMBER 2024 • PREVIOUS VERSION IS NO LONGER VALID. • © COPYRIGHT 2024 BY THERMACUT® CZECH REPUBLIC. ALL RIGHTS RESERVED.

THERMACUT® REPLACEMENT PARTS SUITABLE FOR
Hypertherm®
POWERMAX® 800 | PAC® 121T/M/125T/M

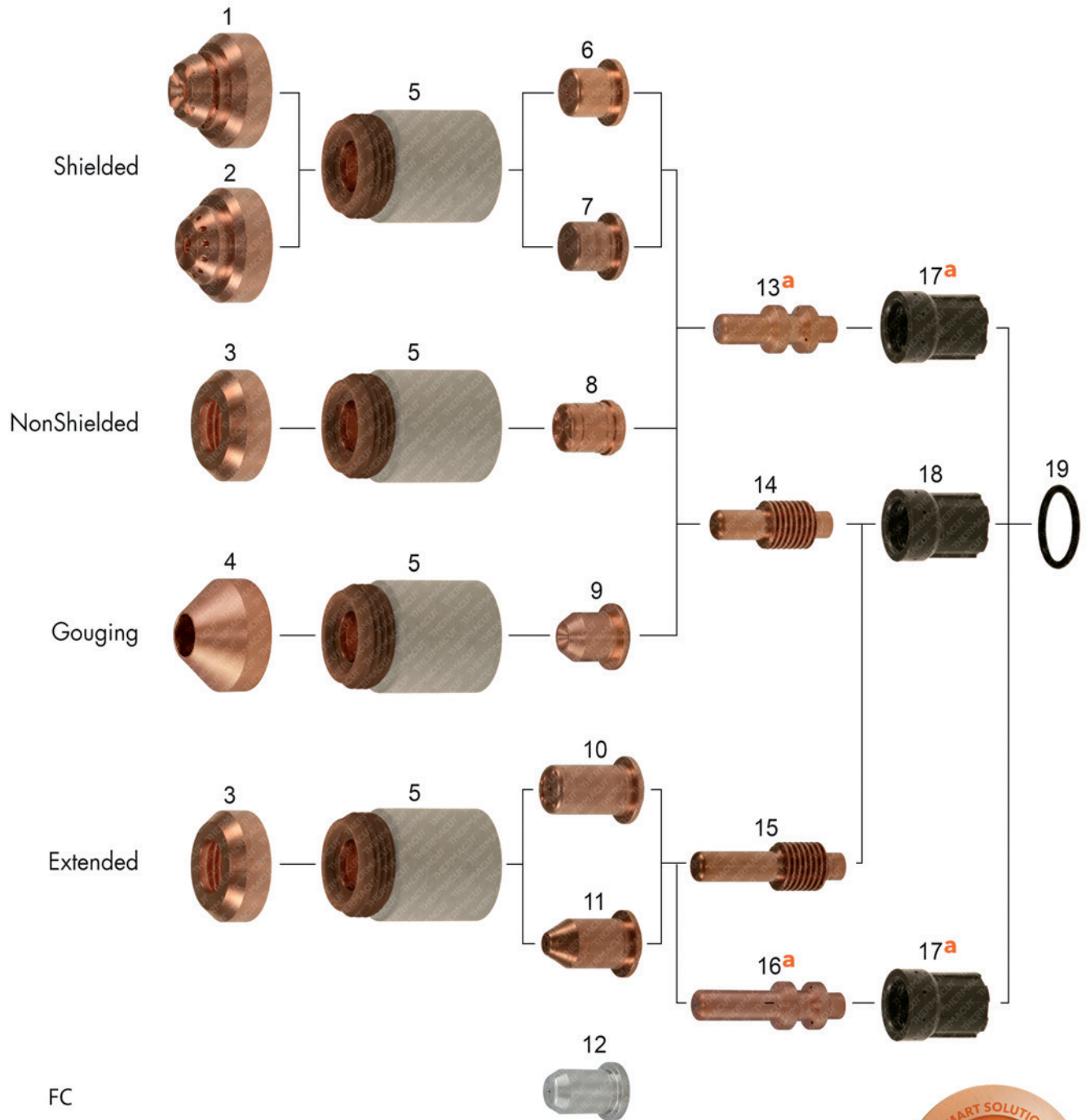

THERMACUT®, FHT-EX® AND EX-TRAFIRE® ARE REGISTERED TRADEMARKS OF THERMACUT, K. S. AND MAY BE REGISTERED IN CZECH REPUBLIC AND/OR OTHER COUNTRIES. ALL OTHER TRADEMARKS ARE PROPERTIES OF THEIR RESPECTIVE OWNERS. THERMACUT IS NO WAY AFFILIATED WITH HYPERTHERM®. MOST THERMACUT PARTS ARE MADE FOR OR BY AN IBG COMPANY. PARTS INDICATED WITH A OEM ARE ORIGINAL PARTS MANUFACTURED BY THE ABOVE NAMED MANUFACTURER AND ARE BEING RESOLD BY THERMACUT. THERMACUT RESERVES THE RIGHT TO SUBSTITUTE OEM PARTS IN PLACE OF THERMACUT PARTS. VALID FROM SEPTEMBER 2024 • PREVIOUS VERSION IS NO LONGER VALID. • © COPYRIGHT 2024 BY THERMACUT® CZECH REPUBLIC. ALL RIGHTS RESERVED.

THERMACUT® REPLACEMENT PARTS SUITABLE FOR
Hypertherm®
POWERMAX® 800 | PAC® 121T/M/125T/M

Item	Part No.	Ref. No.	Description	Std. Pkg.	Item	Part No.	Ref. No.	Description	Std. Pkg.
1.	T-9824	120601-UR	Shield, Hand	1	a 13.	T-4450	120573-UR	Electrode, Long Life	5
2.	T-9825	120602-UR	Shield, Machine	1	14.	T-3419	120573	Electrode	5
3.	T-1564	120303	Deflector	1	15.	T-2298	120574	Electrode, Extended	5
4.	T-3412	120608	Shield, Gouging	1	a 16.	T-4451	120574-UR	Electrode, Extended, Long Life	5
5.	T-12045	120600	Retaining Cap	1	aOD 17.	T-4452	020361-UR	Swirl Ring, Long Life	2
6.	T-1567	120282	Nozzle 50A, Shielded	5	18.	T-0029	020361	Swirl Ring	2
7.	T-3420	120438	Nozzle 40A, Shielded	10	OD 19.	T-0038	044016	O-Ring	10
8.	T-0028	020395	Nozzle, NonShielded	10	NS	T-2852	129001	Torch Lead, 25'	1
9.	T-1568	120281	Nozzle, Gouging	1	NS	T-4500	129002	Torch Lead, 50'	1
10.	T-1569	120304	Nozzle, Extended	5	Different types of cable leads available on request				
11.	T-1570	120305	Nozzle, Pipe Saddle, Extended	5					
12.	T-9999	220330	Nozzle (PAC®123, FC)	5					

***** FULLY INTERCHANGEABLE AND COMPATIBLE WITH ORIGINAL PARTS, BUT DIFFERS FROM ORIGINAL DESIGN

a MUST BE USED ONLY AS THE SET OF ELECTRODE & SWIRL RING, LIKE SHOWN IN THE PICTURE (UR DESIGN VERSION OR OEM DESIGN VERSION) SET OFFERS LIFETIME LONGER UP TO 50%.

OD ON DEMAND – WE DO NOT KEEP THESE PARTS IN STOCK, COST IS SET ACCORDING TO THE ORDERED QUANTITY, DELIVERY TIME MAY DIFFER FROM STANDARD PRODUCTS.

NS NOT SHOWN IN THE PICTURE

SMART SOLUTION – DESIGN IMPROVEMENTS THAT BRINGS ADDED VALUE SUCH AS IMPROVED LIFETIME OF CONSUMABLES, EXCELLENT CUT QUALITY, SPEED OR BETTER COST EFFECTIVENESS OF YOUR SYSTEM.

THERMACUT®, FHT-EX® AND EX-TRAFIRE® ARE REGISTERED TRADEMARKS OF THERMACUT, K. S. AND MAY BE REGISTERED IN CZECH REPUBLIC AND/OR OTHER COUNTRIES. ALL OTHER TRADEMARKS ARE PROPERTIES OF THEIR RESPECTIVE OWNERS. THERMACUT IS NO WAY AFFILIATED WITH HYPERTHERM®. MOST THERMACUT PARTS ARE MADE FOR OR BY AN IBG COMPANY. PARTS INDICATED WITH A OEM ARE ORIGINAL PARTS MANUFACTURED BY THE ABOVE NAMED MANUFACTURER AND ARE BEING RESOLD BY THERMACUT. THERMACUT RESERVES THE RIGHT TO SUBSTITUTE OEM PARTS IN PLACE OF THERMACUT PARTS. VALID FROM SEPTEMBER 2024 • PREVIOUS VERSION IS NO LONGER VALID. • © COPYRIGHT 2024 BY THERMACUT® CZECH REPUBLIC. ALL RIGHTS RESERVED.

THERMACUT® REPLACEMENT PARTS SUITABLE FOR
Hypertherm®
POWERMAX® 900 | PAC® 125T/M

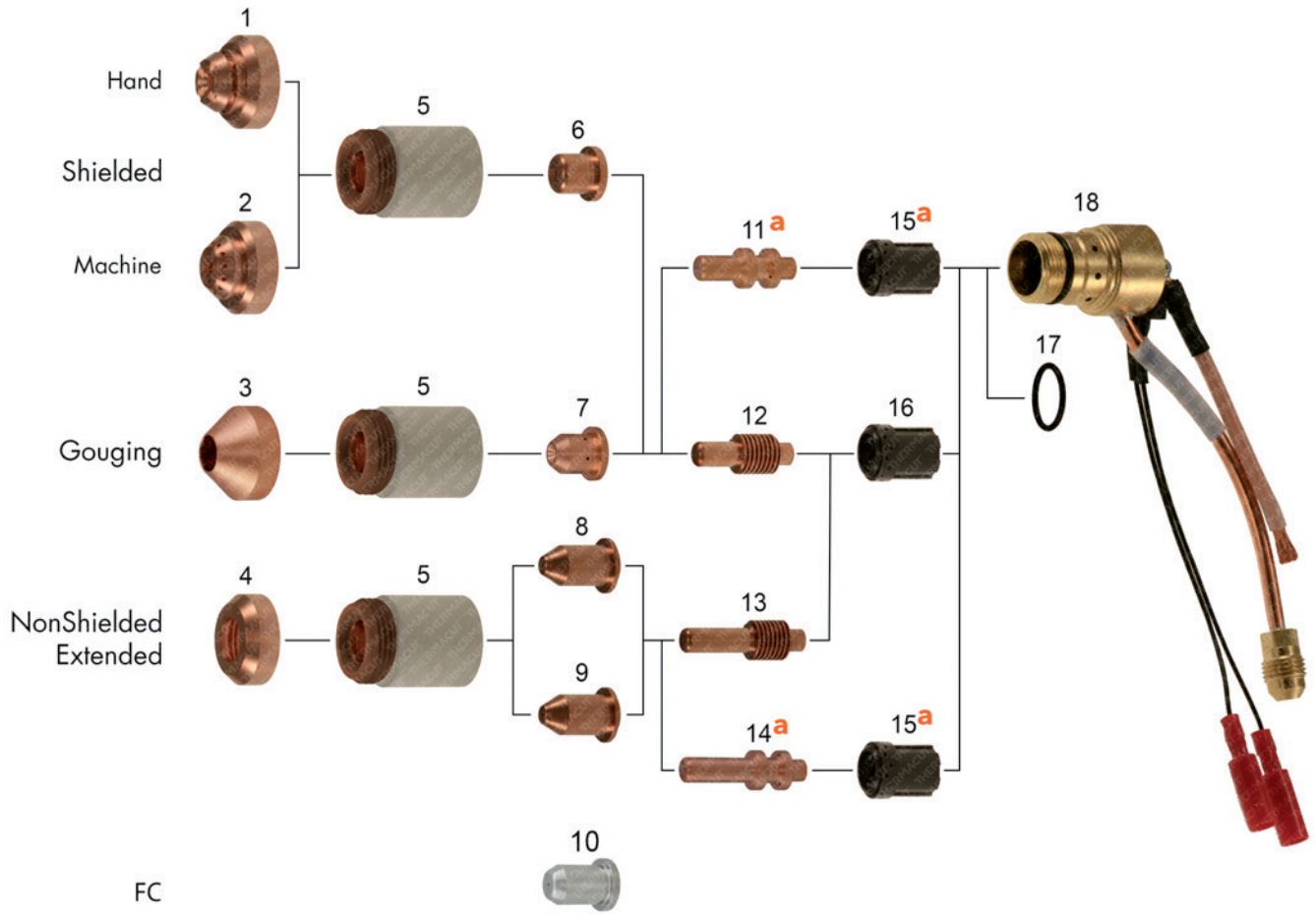

THERMACUT®, FHT-EX® AND EX-TRAFIRE® ARE REGISTERED TRADEMARKS OF THERMACUT, K. S. AND MAY BE REGISTERED IN CZECH REPUBLIC AND/OR OTHER COUNTRIES. ALL OTHER TRADEMARKS ARE PROPERTIES OF THEIR RESPECTIVE OWNERS. THERMACUT IS NO WAY AFFILIATED WITH HYPERTHERM®. MOST THERMACUT PARTS ARE MADE FOR OR BY AN IBG COMPANY. PARTS INDICATED WITH A OEM ARE ORIGINAL PARTS MANUFACTURED BY THE ABOVE NAMED MANUFACTURER AND ARE BEING RESOLD BY THERMACUT. THERMACUT RESERVES THE RIGHT TO SUBSTITUTE OEM PARTS IN PLACE OF THERMACUT PARTS. VALID FROM SEPTEMBER 2024 • PREVIOUS VERSION IS NO LONGER VALID. • © COPYRIGHT 2024 BY THERMACUT® CZECH REPUBLIC. ALL RIGHTS RESERVED.

THERMACUT® REPLACEMENT PARTS SUITABLE FOR
Hypertherm®
POWERMAX® 900 | PAC® 125T/M

Item	Part No.	Ref. No.	Description	Std. Pkg.	Item	Part No.	Ref. No.	Description	Std. Pkg.
1.	T-9824	120601-UR	Shield, Hand	1	13.	T-2298	120574	Electrode, Extended	5
2.	T-9825	120602-UR	Shield, Machine	1	a 14.	T-4451	120574-UR	Electrode, Extended, Long Life	5
3.	T-3412	120608	Shield, Gouging	1	a 15.	T-4453	120576-UR	Swirl Ring, Long Life	2
4.	T-1564	120303	Deflector	1	16.	T-2230	120576	Swirl Ring	2
5.	T-12045	120600	Retaining Cap	1	OD 17.	T-0038	044016	O-Ring	10
6.	T-3414	120577	Nozzle 55A, Shielded	5	18.	T-10269	120570	Torch Main Body with Safety Switch	1
7.	T-3415	120607	Nozzle, Gouging	10	RT NS	T-4185	129352	Torch leads, 25'	1
8.	T-3417	120578	Nozzle 55A, Extended	10	RT NS	T-4186	129353	Torch leads, 50'	1
9.	T-3418	120606	Nozzle 35A, Extended	10	Different types of cable leads available on request.				
10.	T-9999	220330	Nozzle (PAC®123, FC)	5					
a 11.	T-4450	120573-UR	Electrode, Long Life	5					
12.	T-3419	120573	Electrode	5					

***** FULLY INTERCHANGEABLE WITH ORIGINAL PARTS, BUT DIFFERS FROM ORIGINAL DESIGN

a MUST BE USED ONLY AS THE SET OF ELECTRODE & SWIRL RING, LIKE SHOWN IN THE PICTURE (UR DESIGN VERSION OR OEM DESIGN VERSION), SET OFFERS LIFETIME LONGER UP TO 50%.

OD ON DEMAND – WE DO NOT KEEP THESE PARTS IN STOCK, COST IS SET ACCORDING TO THE ORDERED QUANTITY, DELIVERY TIME MAY DIFFER FROM STANDARD PRODUCTS.

NS NOT SHOWN IN THE PICTURE

RT RT60™ AND RT60M™ ARE RETROFIT KITS, WHICH USES CONSUMABLES FOR PRODUCT LINE POWERMAX® 65/85/105 OR 1000/1250/1650, CONSUMABLES SHOWN ABOVE OF THIS PAGE DOESN'T FIT TO THIS TORCHES.

THERMACUT®, FHT-EX® AND EX-TRAFIRE® ARE REGISTERED TRADEMARKS OF THERMACUT, K. S. AND MAY BE REGISTERED IN CZECH REPUBLIC AND/OR OTHER COUNTRIES. ALL OTHER TRADEMARKS ARE PROPERTIES OF THEIR RESPECTIVE OWNERS. THERMACUT IS NO WAY AFFILIATED WITH HYPERTHERM®. MOST THERMACUT PARTS ARE MADE FOR OR BY AN IBG COMPANY. PARTS INDICATED WITH A OEM ARE ORIGINAL PARTS MANUFACTURED BY THE ABOVE NAMED MANUFACTURER AND ARE BEING RESOLD BY THERMACUT. THERMACUT RESERVES THE RIGHT TO SUBSTITUTE OEM PARTS IN PLACE OF THERMACUT PARTS. VALID FROM SEPTEMBER 2024 • PREVIOUS VERSION IS NO LONGER VALID. • © COPYRIGHT 2024 BY THERMACUT® CZECH REPUBLIC. ALL RIGHTS RESERVED.

THERMACUT® REPLACEMENT PARTS SUITABLE FOR
Hypertherm®
POWERMAX® 1000 / POWERMAX® 1250 / POWERMAX® 1650
T60™/T60M™, T80™/T80M™, T100™/T100M™/T100M-2™

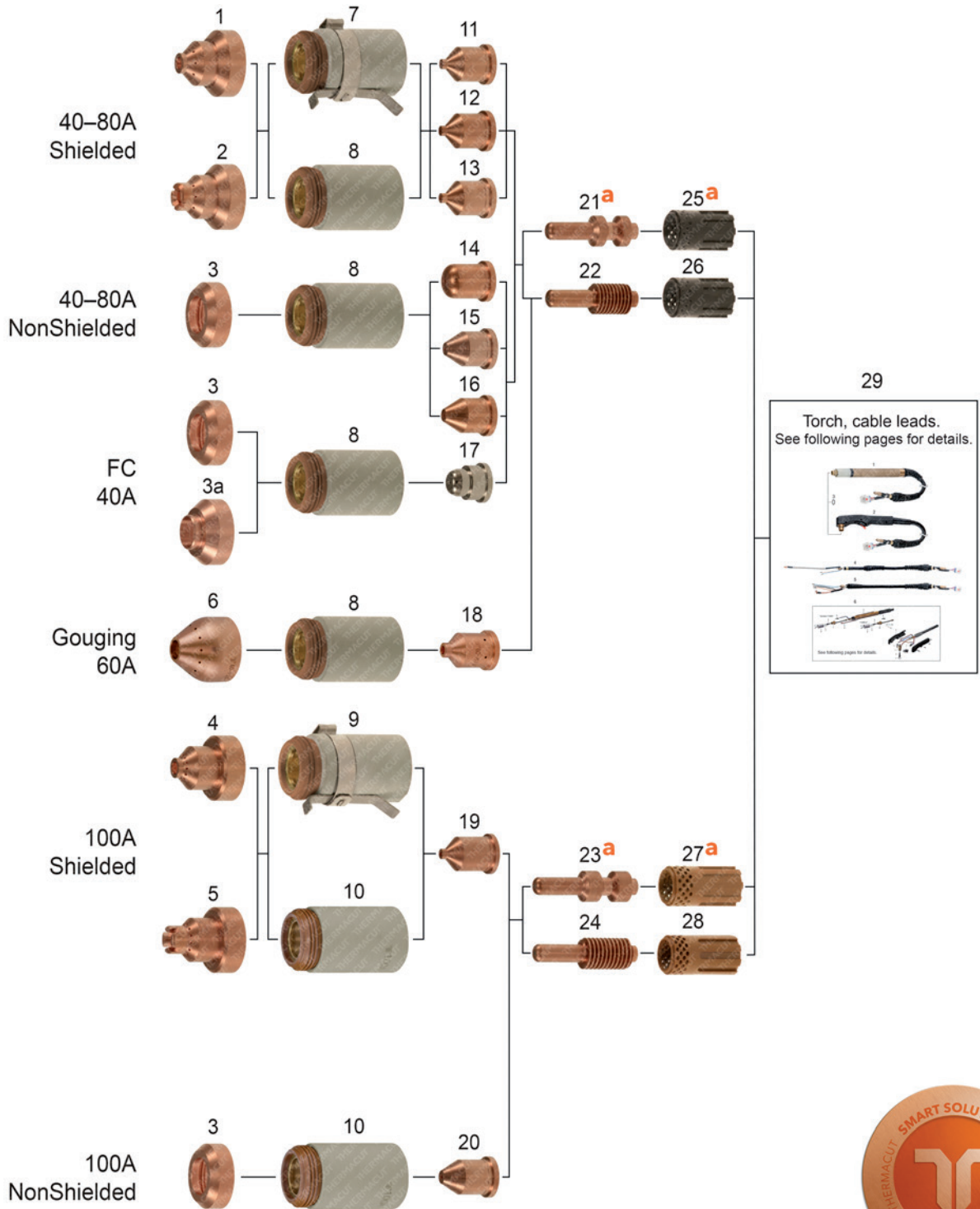

THERMACUT®, FHT-EX® AND EX-TRAFIRE® ARE REGISTERED TRADEMARKS OF THERMACUT, K. S. AND MAY BE REGISTERED IN CZECH REPUBLIC AND/OR OTHER COUNTRIES. ALL OTHER TRADEMARKS ARE PROPERTIES OF THEIR RESPECTIVE OWNERS. THERMACUT IS NO WAY AFFILIATED WITH HYPERTHERM®. MOST THERMACUT PARTS ARE MADE FOR OR BY AN IBG COMPANY. PARTS INDICATED WITH A OEM ARE ORIGINAL PARTS MANUFACTURED BY THE ABOVE NAMED MANUFACTURER AND ARE BEING RESOLD BY THERMACUT. THERMACUT RESERVES THE RIGHT TO SUBSTITUTE OEM PARTS IN PLACE OF THERMACUT PARTS. VALID FROM SEPTEMBER 2024 • PREVIOUS VERSION IS NO LONGER VALID. • © COPYRIGHT 2024 BY THERMACUT® CZECH REPUBLIC. ALL RIGHTS RESERVED.

THERMACUT® REPLACEMENT PARTS SUITABLE FOR
Hypertherm®
POWERMAX® 1000 / POWERMAX® 1250 / POWERMAX® 1650
T60™/T60M™, T80™/T80M™, T100™/T100M™/T100M-2™

Item	Part No.	Ref. No.	Description	Std. Pkg	Item	Part No.	Ref. No.	Description	Std. Pkg
1.	T-9831	120930-UR	Shield 40A/60A/80A, Machine	1	16.	T-3892	120980	Nozzle 80A, Extended	5
2.	T-9830	120929-UR	Shield 40A/60A/80A, Hand	1	17.	T-9998	220329	Nozzle 40A, FC	5
3.	T-4188	120979	Deflector 40A/60A/80A/100A	1	18.	T-11300	220059	Nozzle 60-80A, Gouging	5
3a.	T-10410	220325 OEM	Deflector, CE 40A, FC	10	19.	T-8892	220011	Nozzle 100A	5
4.	T-9832	220047-UR	Shield 100A, Machine	1	20.	T-4190	220064	Nozzle 100A, Extended	5
5.	T-9833	220065-UR	Shield 100A, Hand	1	a 21.	T-4454	120926-UR	Electrode 40A/60A/80A, Long Life	5
6.	T-11299	120977	Shield 60-100A, Gouging	1	22.	T-8401	120926	Electrode 40A/60A/80A	5
7.	T-12067	220061	Retaining Cap 40A/60A/80A, Ohmic	1	a 23.	T-4455	220037-UR	Electrode 100A, Long Life	5
8.	T-12066	120928	Retaining Cap 40A/60A/80A	1	24.	T-8872	220037	Electrode 100A	5
9.	T-12071	220206	Retaining Cap 100A, Ohmic	1	a 25.	T-4456	120925-UR	Swirl Ring 40A/60A/80A, Long Life	2
10.	T-8902	220048	Retaining Cap 100A	1	26.	T-8400	120925	Swirl Ring 40A/60A/80A	2
11.	T-3891	120932	Nozzle 40A	5	a 27.	T-4457	220051-UR	Swirl Ring 100A, Long Life	2
12.	T-8405	120931	Nozzle 60A	5	28.	T-11288	220051	Swirl Ring 100A	5
13.	T-3890	120927	Nozzle 80A	5	29.	Torch, cable leads. See following pages for details.			
14.	T-3889	220006	Nozzle 40A, Extended	5					
15.	T-4572	220007	Nozzle 60A, Extended	5					

* FULLY INTERCHANGEABLE AND COMPATIBLE WITH ORIGINAL PARTS, BUT DIFFERS FROM ORIGINAL DESIGN

a MUST BE USED ONLY AS THE SET OF ELECTRODE & SWIRL RING, LIKE SHOWN IN THE PICTURE (UR DESIGN VERSION OR OEM DESIGN VERSION), SET OFFERS LIFETIME LONGER UP TO 50%

SMART SOLUTION – DESIGN IMPROVEMENTS THAT BRINGS ADDED VALUE SUCH AS IMPROVED LIFETIME OF CONSUMABLES, EXCELLENT CUT QUALITY, SPEED OR BETTER COST EFFECTIVENESS OF YOUR SYSTEM

THERMACUT®, FHT-EX® AND EX-TRAFIRE® ARE REGISTERED TRADEMARKS OF THERMACUT, K. S. AND MAY BE REGISTERED IN CZECH REPUBLIC AND/OR OTHER COUNTRIES. ALL OTHER TRADEMARKS ARE PROPERTIES OF THEIR RESPECTIVE OWNERS. THERMACUT IS NO WAY AFFILIATED WITH HYPERTHERM®. MOST THERMACUT PARTS ARE MADE FOR OR BY AN IBG COMPANY. PARTS INDICATED WITH A OEM ARE ORIGINAL PARTS MANUFACTURED BY THE ABOVE NAMED MANUFACTURER AND ARE BEING RESOLD BY THERMACUT. THERMACUT RESERVES THE RIGHT TO SUBSTITUTE OEM PARTS IN PLACE OF THERMACUT PARTS. VALID FROM SEPTEMBER 2024 • PREVIOUS VERSION IS NO LONGER VALID. • © COPYRIGHT 2024 BY THERMACUT® CZECH REPUBLIC. ALL RIGHTS RESERVED.

THERMACUT® REPLACEMENT PARTS SUITABLE FOR
Hypertherm®
POWERMAX® 1000 / POWERMAX® 1250 / POWERMAX® 1650
T60™/T60M™ TORCH, T80™/T80M™ TORCH, T100™/T100M™ TORCH

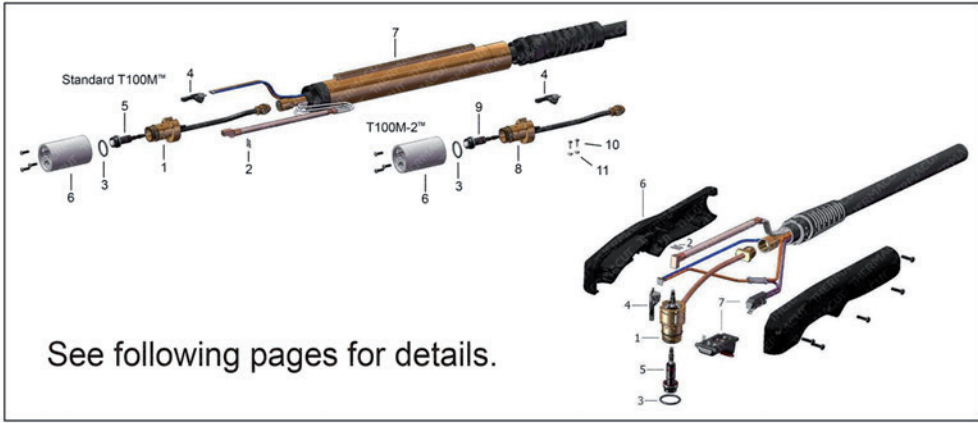
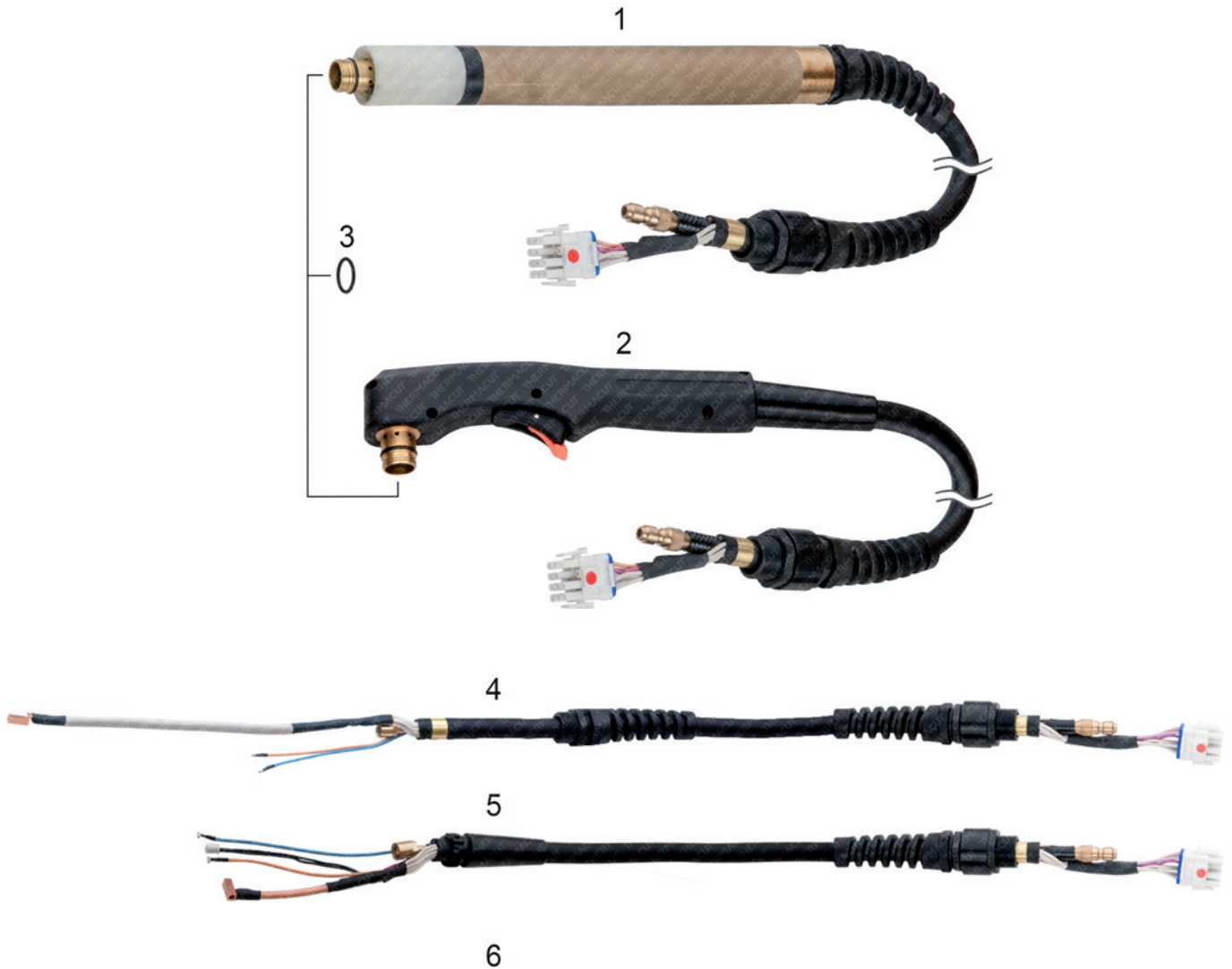

THERMACUT®, FHT-EX® AND EX-TRAFIRE® ARE REGISTERED TRADEMARKS OF THERMACUT, K. S. AND MAY BE REGISTERED IN CZECH REPUBLIC AND/OR OTHER COUNTRIES. ALL OTHER TRADEMARKS ARE PROPERTIES OF THEIR RESPECTIVE OWNERS. THERMACUT IS NO WAY AFFILIATED WITH HYPERTHERM®. MOST THERMACUT PARTS ARE MADE FOR OR BY AN IBG COMPANY. PARTS INDICATED WITH A OEM ARE ORIGINAL PARTS MANUFACTURED BY THE ABOVE NAMED MANUFACTURER AND ARE BEING RESOLD BY THERMACUT. THERMACUT RESERVES THE RIGHT TO SUBSTITUTE OEM PARTS IN PLACE OF THERMACUT PARTS. VALID FROM SEPTEMBER 2024 • PREVIOUS VERSION IS NO LONGER VALID. • © COPYRIGHT 2024 BY THERMACUT® CZECH REPUBLIC. ALL RIGHTS RESERVED.

**THERMACUT® REPLACEMENT PARTS SUITABLE FOR
Hypertherm®
POWERMAX® 1000 / POWERMAX® 1250 / POWERMAX® 1650
T60™/T60M™ TORCH, T80™/T80M™ TORCH, T100™/T100M™ TORCH**

Item	Part No.	Ref. No.	Description	Std. Pkg.	Item	Part No.	Ref. No.	Description	Std. Pkg.
1.	KT-1194	083175-UR	T60M™ Machine Torch with Leads 4.6m (15')	1	*	KT-1149*	059270-UR	T100™ Hand Torch with Leads 15.2m (50')	1
*	KT-1138*	083174-UR	T60M™ Machine Torch with Leads 7.6m (25')	1	*	KT-1345*	059499-UR	=059270-UR	1
*	KT-1195*	083176-UR	T60M™ Machine Torch with Leads 10.7m (35')	1	3.	T-4510	058519	O-Ring	10
*	KT-1196*	083177-UR	T60M™ Machine Torch with Leads 15.2m (50')	1	*4.	KT-1136*	128681-UR	T60™ Cable Leads, Hand 7.6m (25')	1
*	KT-1193*	087003-UR	T80M™ Machine Torch with Leads 4.6m (15')	1	*	KT-1140*	128682-UR	T60™ Cable Leads, Hand 15.2m (50')	1
*	KT-1134*	087004-UR	T80M™ Machine Torch with Leads 7.6m (25')	1	*5.	KT-1192*	128634-UR	T60M™/T80M™ Cable Leads, Machine 4.6m (15')	1
*	KT-1184*	087005-UR	T80M™ Machine Torch with Leads 10.7m (35')	1	*	KT-1133*	128633-UR	T60M™/T80M™ Cable Leads, Machine 7.6m (25')	1
*	KT-1163*	087006-UR	T80M™ Machine Torch with Leads 15.2m (50')	1	*	KT-1183*	128635-UR	T60M™/T80M™ Cable Leads, Machine 10.7m (35')	1
*	KT-1124*	059265-UR	T100M™ Machine Torch with Leads 7.6m (25')	1	*	KT-1162*	128641-UR	T60M™/T80M™ Cable Leads, Machine 15.2m (50')	1
*	KT-1170*	059268-UR	T100M™ Machine Torch with Leads 10.7m (35')	1	*4.	KT-1144*	128636-UR	T80™ Cable Leads, Hand 15.2m (50')	1
*	KT-1175*	059272-UR	T100M™ Machine Torch with Leads 15.2m (50')	1	*	KT-1146*	128893-UR	T80™ Cable Leads, Hand 22.9m (75')	1
*	KT-1450*	059315-UR	T100M-2™ Machine Torch with Leads 7.6m (25')	1	*	KT-1121*	128755-UR	T100™ Cable Leads, Hand 7.6m (25')	1
*	KT-1395*	059325-UR	T100M-2™ Machine Torch with Leads 15.2m (50')	1	*	KT-1148*	128752-UR	T100™ Cable Leads, Hand 15.2m (50')	1
*	T-13153*	059326-UR	T100M-2™ Machine Torch with Leads 22.9m (75')	1	*5.	KT-1122*	128753-UR	T100M™ Cable Leads, Machine 7.6m (25')	1
*	KT-1259*	059300-UR	T100M™ Machine Torch with Leads 22.9m (75')	1	*	KT-1169*	128751-UR	T100M™ Cable Leads, Machine 10.7m (35')	1
2.	KT-1137	083172-UR	T60™ Hand Torch with Leads 7.6m (25')	1	*	KT-1174*	128759-UR	T100M™ Cable Leads, Machine 15.2m (50')	1
*	KT-1141*	083171-UR	T60™ Hand Torch with Leads 15.2m (50')	1	*	KT-1258*	KT100M.22,9M.K	T100M™ Cable Leads, Machine 22.9m (75')	1
*	KT-1143*	083208-UR	T60™ Hand Torch with Leads 22.9m (75')	1	*	KT-1467*	228222-UR	T100M-2™ Cable Leads, Machine 7.6m (25')	1
*	KT-1131*	087001-UR	T80™ Hand Torch with Leads 7.6m (25')	1	*	KT-1396*	228224-UR	T100M-2™ Cable Leads, Machine 15.2m (50')	1
*	KT-1145*	087002-UR	T80™ Hand Torch with Leads 15.2m (50')	1	6.			Torch, cable leads. See following pages for details.	
*	KT-1147*	087047-UR	T80™ Hand Torch with Leads 22.9m (75')	1					
*	KT-1123*	059264-UR	T100™ Hand Torch with Leads 7.6m (25')	1					

* FULLY INTERCHANGEABLE WITH ORIGINAL PARTS, BUT DIFFERS FROM ORIGINAL DESIGN

THERMACUT®, FHT-EX® AND EX-TRAFIRE® ARE REGISTERED TRADEMARKS OF THERMACUT, K. S. AND MAY BE REGISTERED IN CZECH REPUBLIC AND/OR OTHER COUNTRIES. ALL OTHER TRADEMARKS ARE PROPERTIES OF THEIR RESPECTIVE OWNERS. THERMACUT IS NO WAY AFFILIATED WITH HYPERTHERM®. MOST THERMACUT PARTS ARE MADE FOR OR BY AN IBC COMPANY. PARTS INDICATED WITH A OEM ARE ORIGINAL PARTS MANUFACTURED BY THE ABOVE NAMED MANUFACTURER AND ARE BEING RESOLD BY THERMACUT. THERMACUT RESERVES THE RIGHT TO SUBSTITUTE OEM PARTS IN PLACE OF THERMACUT PARTS. VALID FROM SEPTEMBER 2024 • PREVIOUS VERSION IS NO LONGER VALID. • © COPYRIGHT 2024 BY THERMACUT® CZECH REPUBLIC. ALL RIGHTS RESERVED.

**THERMACUT® REPLACEMENT PARTS SUITABLE FOR
Hypertherm®
POWERMAX® 1000 / POWERMAX® 1250 | T60M™/T80M™ MACHINE TORCH**

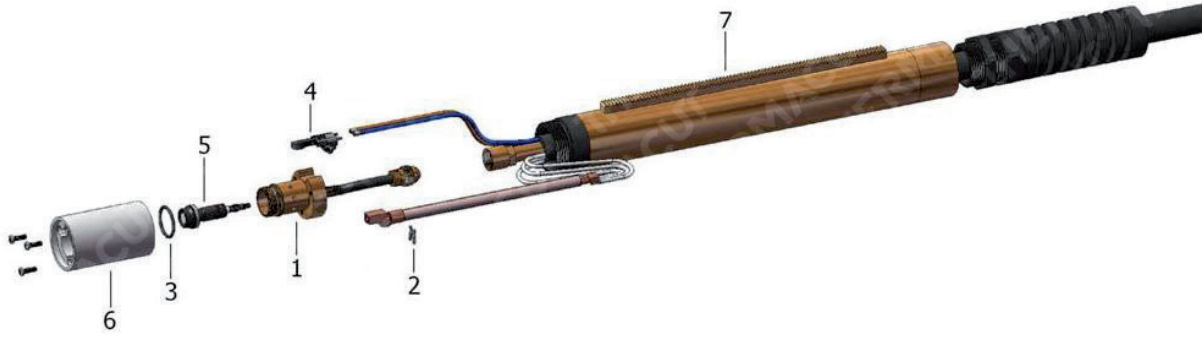

Item	Part No.	Ref. No.	Description	Std. Pkg.	Item	Part No.	Ref. No.	Description	Std. Pkg.
1.	T-10319	128640-UR	T60M™/T80M™ Torch Body Kit (incl. items 1, 2, 3, 5)	1	*5.	T-10253*	128521-UR	T60™, T80™/T60M™, T80M™ Torch Head Repair Kit	1
2.	T-10237	027889 OEM	Retaining Clip	1	*6.	PT-12161*	128643-UR	Torch Mounting Sleeve Replacement Kit with Screws	1
3.	T-4510	058519	O-Ring	10	7.	T-12159	128710	Torch Positioning Sleeve	1
4.	T-10615	128639-UR	TMT Cap-off Sensor Replacement Kit with Screws	1					

**THERMACUT® REPLACEMENT PARTS SUITABLE FOR
POWERMAX® 1000 / POWERMAX® 1250 | T60™/T80™ HAND TORCH**



Item	Part No.	Ref. No.	Description	Std. Pkg.	Item	Part No.	Ref. No.	Description	Std. Pkg.
1.	T-10281	128564-UR	T60™/T80™ Torch Body Kit (incl. items 1, 2, 3, 5)	1	*5.	T-10253*	128521-UR	T60™, T80™/T60M™, T80M™ Torch Head Repair Kit	1
2.	T-10237	027889 OEM	Retaining Clip	1	a 6.	T-10623	128644-UR	TMT Handle Kit with Screws	1
3.	T-4510	058519	O-Ring	10	a 7.	T-10849	T-10849	Trigger + Switch	1
a 4.	T-10615	128639-UR	TMT Cap-off Sensor Replacement Kit with Screws	1	4., 6., 7.	T-10838	T-10838	T60™/T80™/T100™ Handle Repl. Assy	1

* FULLY INTERCHANGEABLE AND COMPATIBLE WITH ORIGINAL PARTS, BUT DIFFERS FROM ORIGINAL DESIGN

a MUST BE USED ONLY AS A SET OF ITEMS 4, 6, 7, THIS COMPLETE SET IS INTERCHANGEABLE AND COMPATIBLE WITH ORIGINAL PARTS.

THERMACUT®, FHT-EX® AND EX-TRAFIRE® ARE REGISTERED TRADEMARKS OF THERMACUT, K. S. AND MAY BE REGISTERED IN CZECH REPUBLIC AND/OR OTHER COUNTRIES. ALL OTHER TRADEMARKS ARE PROPERTIES OF THEIR RESPECTIVE OWNERS. THERMACUT IS NO WAY AFFILIATED WITH HYPERTHERM®. MOST THERMACUT PARTS ARE MADE FOR OR BY AN IBG COMPANY. PARTS INDICATED WITH A OEM ARE ORIGINAL PARTS MANUFACTURED BY THE ABOVE NAMED MANUFACTURER AND ARE BEING RESOLD BY THERMACUT. THERMACUT RESERVES THE RIGHT TO SUBSTITUTE OEM PARTS IN PLACE OF THERMACUT PARTS. VALID FROM SEPTEMBER 2024 • PREVIOUS VERSION IS NO LONGER VALID. • © COPYRIGHT 2024 BY THERMACUT® CZECH REPUBLIC. ALL RIGHTS RESERVED.

THERMACUT® REPLACEMENT PARTS SUITABLE FOR Hypertherm® POWERMAX® 1650 | T100M™, T100M-2™ MACHINE TORCH

T100M™ back view



T100M-2™ back view

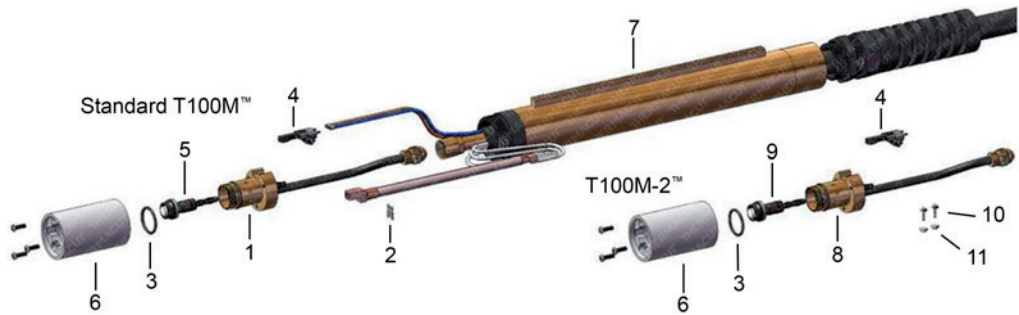

Item	Part No.	Ref. No.	Description	Std. Pkg.	Item	Part No.	Ref. No.	Description	Std. Pkg.	
1.	T-10446	128754-UR	T100M™ Torch Body Kit (incl. items 2, 3, 5)	1	7.	T-12159	128710	Torch Positioning Sleeve	1	
OD	2.	T-10237	027889 OEM	1	*8.	T-11291	228523-UR	T100M-2™ Torch Body Kit (incl. items 3, 9, 10, 11)	1	
	3.	T-4510	058519	10	*9.	T-11292	228522-UR	T100M-2™ Torch Head Repair Kit	1	
	4.	T-10615	128639-UR	1	OD	10.	T-11344	075473	Machine Screws	2
	5.	T-10473	128768-UR	1	OD	11.	T-11345	075503	Lock Nuts	2
	6.	PT-12161	128643-UR	1						

THERMACUT® REPLACEMENT PARTS SUITABLE FOR POWERMAX® 1650 T100™ HAND TORCH



Item	Part No.	Ref. No.	Description	Std. Pkg.	Item	Part No.	Ref. No.	Description	Std. Pkg.	
1.	T-10444	128767-UR	T100™ Torch Body Kit (incl. items 2, 3, 5)	1	a	6.	T-10623	128644-UR	TMT Handle Kit with Screws	1
OD	2.	T-10237	027889 OEM	1	a	7.	T-10849	T-10849	Trigger + Switch	1
	3.	T-4510	058519	10	4, 6, 7.	T-10838	T-10838	T60™/T80™/T100™ Handle Repl. Assy	1	
a	4.	T-10615	128639-UR	1	1.-7.	T-10840	T-10840	T100™ Torch Handle Repl. Assy	1	
5.	T-10473	128768-UR	T100™/T100M™ Torch Head Repair Kit	1						

* FULLY INTERCHANGEABLE AND COMPATIBLE WITH ORIGINAL PARTS, BUT DIFFERS FROM ORIGINAL DESIGN

a MUST BE USED ONLY AS A SET OF ITEMS 4, 6, 7, THIS COMPLETE SET IS INTERCHANGEABLE AND COMPATIBLE WITH ORIGINAL PARTS.

OD ON DEMAND – WE DO NOT KEEP THESE PARTS IN STOCK, COST IS SET ACCORDING TO THE ORDERED QUANTITY, DELIVERY TIME MAY DIFFER FROM STANDARD PRODUCTS.

THERMACUT®, FHT-EX® AND EX-TRAFIRE® ARE REGISTERED TRADEMARKS OF THERMACUT, K. S. AND MAY BE REGISTERED IN CZECH REPUBLIC AND/OR OTHER COUNTRIES. ALL OTHER TRADEMARKS ARE PROPERTIES OF THEIR RESPECTIVE OWNERS. THERMACUT IS NO WAY AFFILIATED WITH HYPERTHERM®. MOST THERMACUT PARTS ARE MADE FOR OR BY AN IBG COMPANY. PARTS INDICATED WITH A OEM ARE ORIGINAL PARTS MANUFACTURED BY THE ABOVE NAMED MANUFACTURER AND ARE BEING RESOLD BY THERMACUT. THERMACUT RESERVES THE RIGHT TO SUBSTITUTE OEM PARTS IN PLACE OF THERMACUT PARTS. VALID FROM SEPTEMBER 2024 • PREVIOUS VERSION IS NO LONGER VALID. • © COPYRIGHT 2024 BY THERMACUT® CZECH REPUBLIC. ALL RIGHTS RESERVED.

THERMACUT® REPLACEMENT PARTS SUITABLE FOR
Hypertherm®
POWERMAX® 1000 / POWERMAX® 1250 / POWERMAX® 1650
DURAMAX® HAND TORCH, DURAMAX® MACHINE TORCH

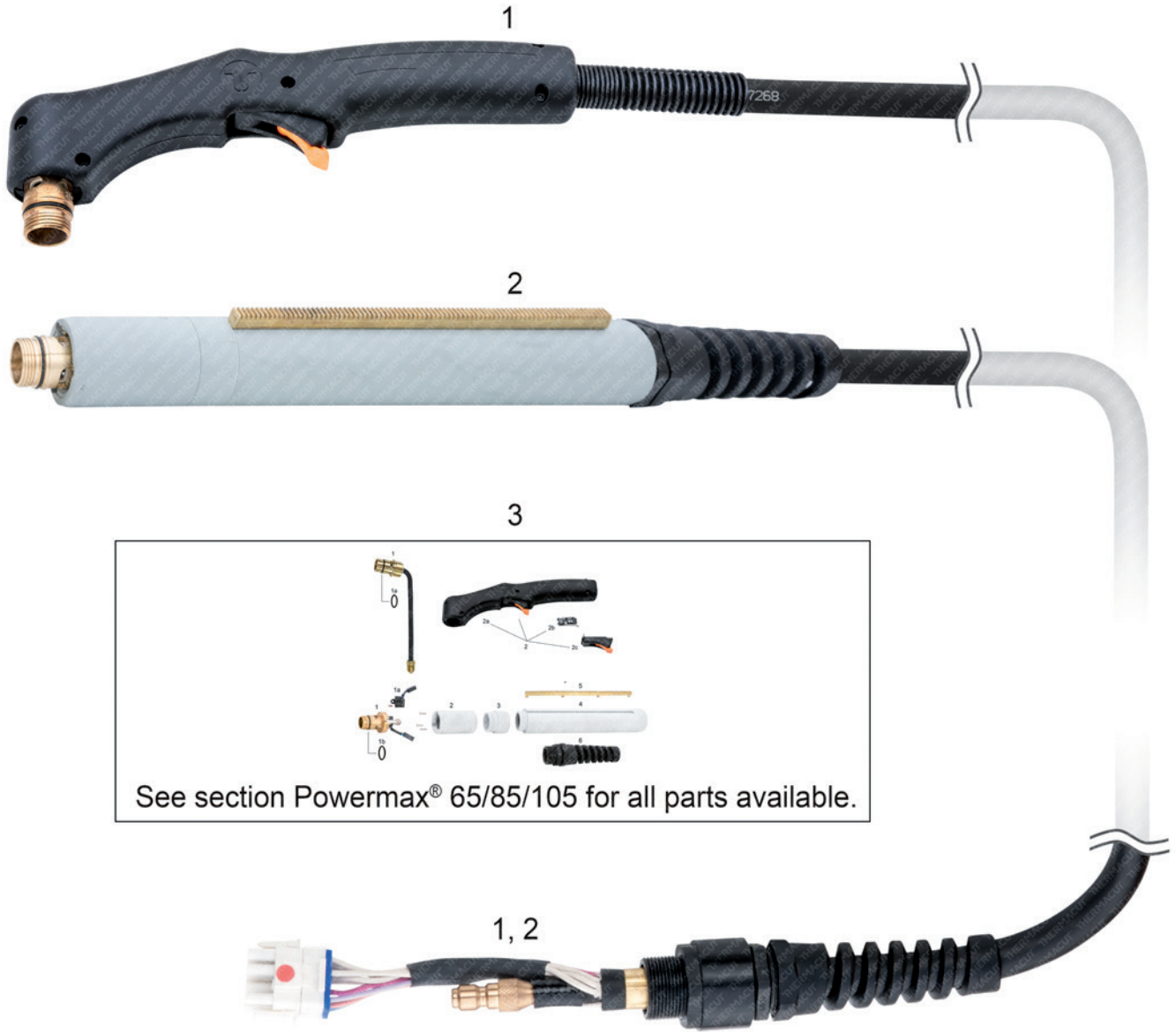

THERMACUT®, FHT-EX® AND EX-TRAFIRE® ARE REGISTERED TRADEMARKS OF THERMACUT, K. S. AND MAY BE REGISTERED IN CZECH REPUBLIC AND/OR OTHER COUNTRIES. ALL OTHER TRADEMARKS ARE PROPERTIES OF THEIR RESPECTIVE OWNERS. THERMACUT IS NO WAY AFFILIATED WITH HYPERTHERM®. MOST THERMACUT PARTS ARE MADE FOR OR BY AN IBG COMPANY. PARTS INDICATED WITH A OEM ARE ORIGINAL PARTS MANUFACTURED BY THE ABOVE NAMED MANUFACTURER AND ARE BEING RESOLD BY THERMACUT. THERMACUT RESERVES THE RIGHT TO SUBSTITUTE OEM PARTS IN PLACE OF THERMACUT PARTS. VALID FROM SEPTEMBER 2024 • PREVIOUS VERSION IS NO LONGER VALID. • © COPYRIGHT 2024 BY THERMACUT® CZECH REPUBLIC. ALL RIGHTS RESERVED.

**THERMACUT® REPLACEMENT PARTS SUITABLE FOR
Hypertherm®
POWERMAX® 1000 / POWERMAX® 1250 / POWERMAX® 1650
DURAMAX® HAND TORCH, DURAMAX® MACHINE TORCH**

Item	Part No.	Ref. No.	Description	Std. Pkg.
1.	T-13155	228788-UR	DURAMAX® G3 Hand Torch with Leads 7.6m (25'), retrofit connection to POWERMAX® 1000/1250/1650	1
	T-13156	228789-UR	DURAMAX® G3 Hand Torch with Leads 15.2m (50'), retrofit connection to POWERMAX® 1000/1250/1650	1
2.	T-13157	228790-UR	DURAMAX® G3 Machine Torch with Leads 7.6m (25'), retrofit connection to POWERMAX® 1000/1250/1650	1
	T-13158	228791-UR	DURAMAX® G3 Machine Torch with Leads 15.2m (50'), retrofit connection to POWERMAX® 1000/1250/1650	1
3.	See section POWERMAX® 65/85/105 for all parts available.			

THERMACUT®, FHT-EX® AND EX-TRAFIRE® ARE REGISTERED TRADEMARKS OF THERMACUT, K. S. AND MAY BE REGISTERED IN CZECH REPUBLIC AND/OR OTHER COUNTRIES. ALL OTHER TRADEMARKS ARE PROPERTIES OF THEIR RESPECTIVE OWNERS. THERMACUT IS NO WAY AFFILIATED WITH HYPERTHERM®. MOST THERMACUT PARTS ARE MADE FOR OR BY AN IBG COMPANY. PARTS INDICATED WITH A OEM ARE ORIGINAL PARTS MANUFACTURED BY THE ABOVE NAMED MANUFACTURER AND ARE BEING RESOLD BY THERMACUT. THERMACUT RESERVES THE RIGHT TO SUBSTITUTE OEM PARTS IN PLACE OF THERMACUT PARTS.
VALID FROM SEPTEMBER 2024 • PREVIOUS VERSION IS NO LONGER VALID. • © COPYRIGHT 2024 BY THERMACUT® CZECH REPUBLIC. ALL RIGHTS RESERVED.

THERMACUT® REPLACEMENT PARTS SUITABLE FOR
Hypertherm®
POWERMAX® 30 XP, AIR | T30V™ HAND TORCH

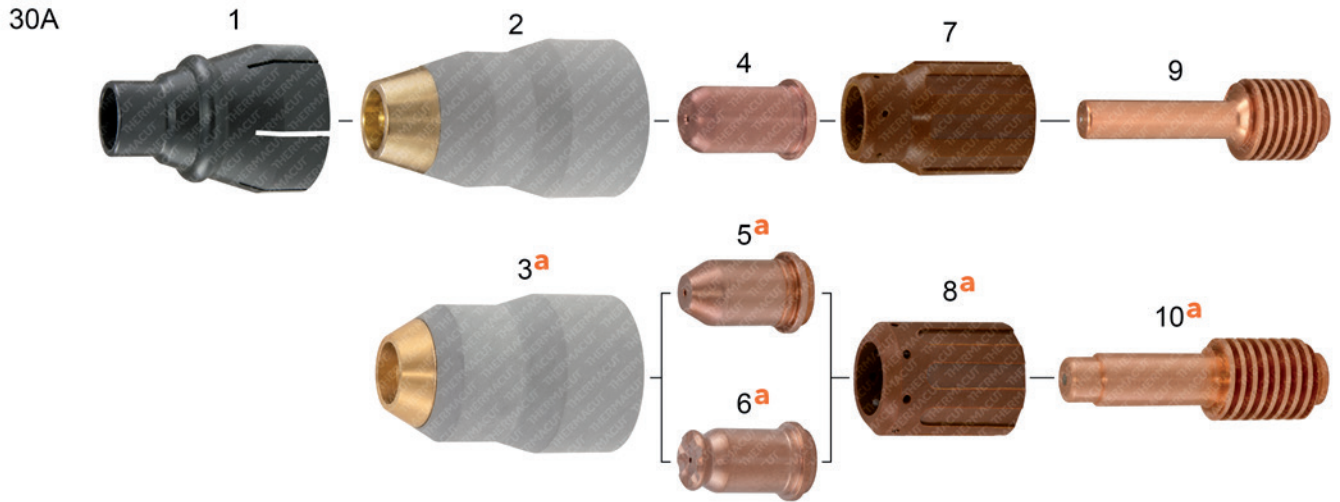

Item	Part No.	Ref. No.	Description	Std. Pkg.	Item	Part No.	Ref. No.	Description	Std. Pkg.
1.	T-10777	220569 OEM	Deflector	1	7.	T-11235	220479	Swirl Ring	1
2.	T-11279	220483	Retaining Cap	1	a 8.	T-11848	220479-UR	Swirl Ring	2
a 3.	T-11852	220483-UR	Retaining Cap	1	9.	T-10758	220478 OEM	Electrode	10
4.	T-11234	220480	Nozzle	5	a 10.	T-11850	220478-UR	Electrode	5
a 5.	T-11849	220480-UR	Nozzle	5					
a 6.	T-11943	220480-D	Nozzle Drag	5					

a MUST BE USED ONLY AS A SET OF RETAINING CAP, NOZZLE, SWIRL RING, ELECTRODE, THIS COMPLETE SET IS COMPATIBLE WITH ORIGINAL TORCH BODY.

THERMACUT®, FHT-EX® AND EX-TRAFIRE® ARE REGISTERED TRADEMARKS OF THERMACUT, K. S. AND MAY BE REGISTERED IN CZECH REPUBLIC AND/OR OTHER COUNTRIES. ALL OTHER TRADEMARKS ARE PROPERTIES OF THEIR RESPECTIVE OWNERS. THERMACUT IS NO WAY AFFILIATED WITH HYPERTHERM®. MOST THERMACUT PARTS ARE MADE FOR OR BY AN IBG COMPANY. PARTS INDICATED WITH A OEM ARE ORIGINAL PARTS MANUFACTURED BY THE ABOVE NAMED MANUFACTURER AND ARE BEING RESOLD BY THERMACUT. THERMACUT RESERVES THE RIGHT TO SUBSTITUTE OEM PARTS IN PLACE OF THERMACUT PARTS. VALID FROM SEPTEMBER 2024 • PREVIOUS VERSION IS NO LONGER VALID. • © COPYRIGHT 2024 BY THERMACUT® CZECH REPUBLIC. ALL RIGHTS RESERVED.

THERMACUT® REPLACEMENT PARTS SUITABLE FOR
Hypertherm®
POWERMAX® 45 | T30v™/T45v™ HAND TORCH, T45m™ MACHINE TORCH

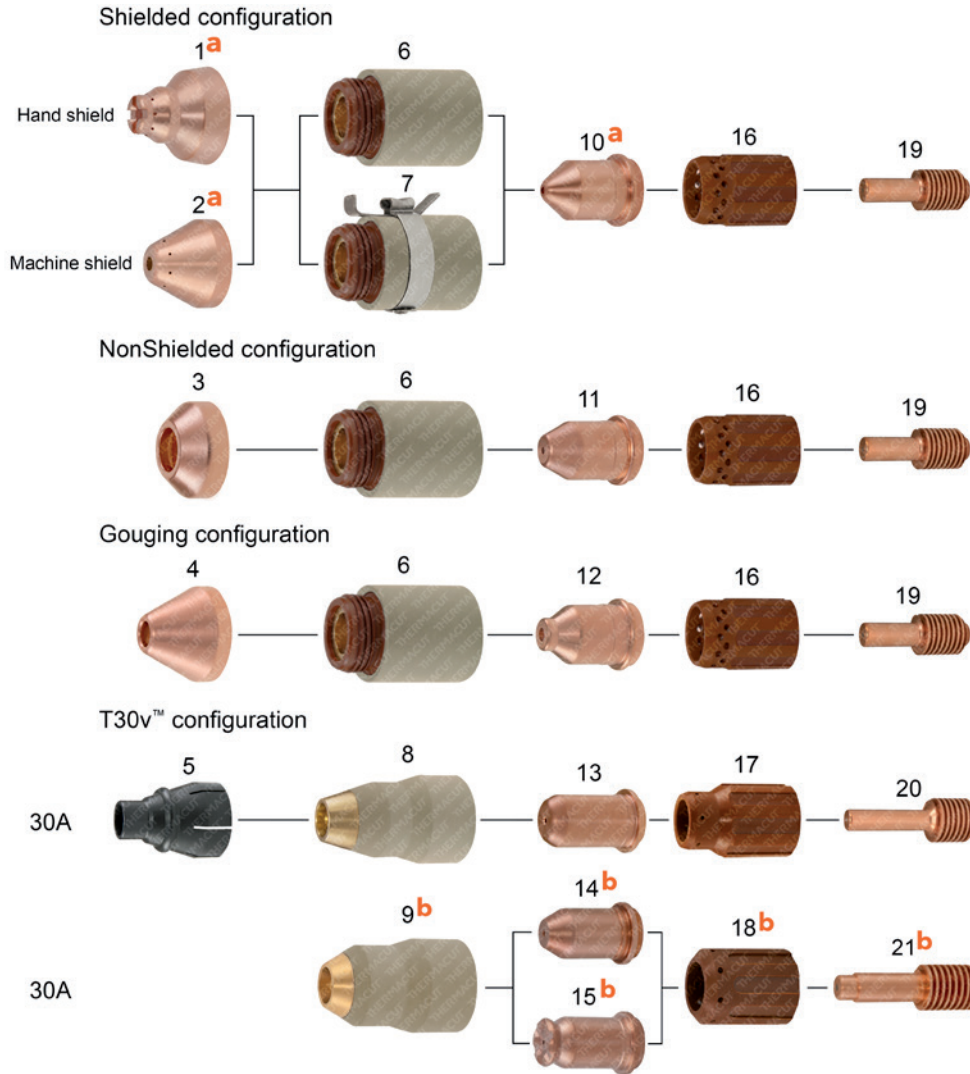

Item	Part No.	Ref. No.	Description	Std. Pkg.	Item	Part No.	Ref. No.	Description	Std. Pkg.
a 1.	T-11393	220674-UR	Shield, Hand	1	12.	T-11394	220672	Nozzle, Gouging	5
a 2.	T-11398	220673-UR	Shield, Machine	1	13.	T-11234	220480	Nozzle 30A	5
3.	T-11213	220717	Deflector	1	b 14.	T-11849	220480-UR	Nozzle	5
4.	T-11392	220675	Shield, Gouging	1	b 15.	T-11943	220480-D	Nozzle Drag	5
5.	T-10777	220569 OEM	Deflector (optional)	1	16.	T-11212	220670	Swirl Ring 45A	1
6.	T-12074	220713	Retaining Cap 45A, without IHS tab	1	17.	T-11235	220479	Swirl Ring 30A	1
7.	T-12075	220719	Retaining Cap 45A, with IHS tab	1	b 18.	T-11848	220479-UR	Swirl Ring	2
8.	T-11279	220483	Retaining Cap 30A	1	19.	T-11236	220669	Electrode 45A	5
b 9.	T-11852	220483-UR	Retaining Cap	1	20.	T-10758	220478 OEM	Electrode 30A	10
a 10.	T-11395	220671-UR	Nozzle, Shielded	5	b 21.	T-11850	220478-UR	Electrode	5
11.	T-11214	220718	Nozzle, NonShielded	5	NS		059473-UR	Hand Torch with 25' Leads	1

a MUST BE USED ONLY AS A SET OF SHIELD AND NOZZLE, THIS COMPLETE SET IS INTERCHANGEABLE AND COMPATIBLE WITH ORIGINAL PARTS.

b MUST BE USED ONLY AS A SET OF RETAINING CAP, NOZZLE, SWIRL RING, ELECTRODE, THIS COMPLETE SET IS COMPATIBLE WITH ORIGINAL TORCH BODY.

NS NOT SHOWN IN THE PICTURE

THERMACUT®, FHT-EX® AND EX-TRAFIRE® ARE REGISTERED TRADEMARKS OF THERMACUT, K. S. AND MAY BE REGISTERED IN CZECH REPUBLIC AND/OR OTHER COUNTRIES. ALL OTHER TRADEMARKS ARE PROPERTIES OF THEIR RESPECTIVE OWNERS. THERMACUT IS NO WAY AFFILIATED WITH HYPERTHERM®. MOST THERMACUT PARTS ARE MADE FOR OR BY AN IBG COMPANY. PARTS INDICATED WITH A OEM ARE ORIGINAL PARTS MANUFACTURED BY THE ABOVE NAMED MANUFACTURER AND ARE BEING RESOLD BY THERMACUT. THERMACUT RESERVES THE RIGHT TO SUBSTITUTE OEM PARTS IN PLACE OF THERMACUT PARTS. VALID FROM SEPTEMBER 2024 • PREVIOUS VERSION IS NO LONGER VALID. • © COPYRIGHT 2024 BY THERMACUT® CZECH REPUBLIC. ALL RIGHTS RESERVED.

THERMACUT® REPLACEMENT PARTS SUITABLE FOR
Hypertherm®
POWERMAX® 45XP | DURAMAX® HAND TORCH, DURAMAX® MACHINE TORCH

45/65/85A application

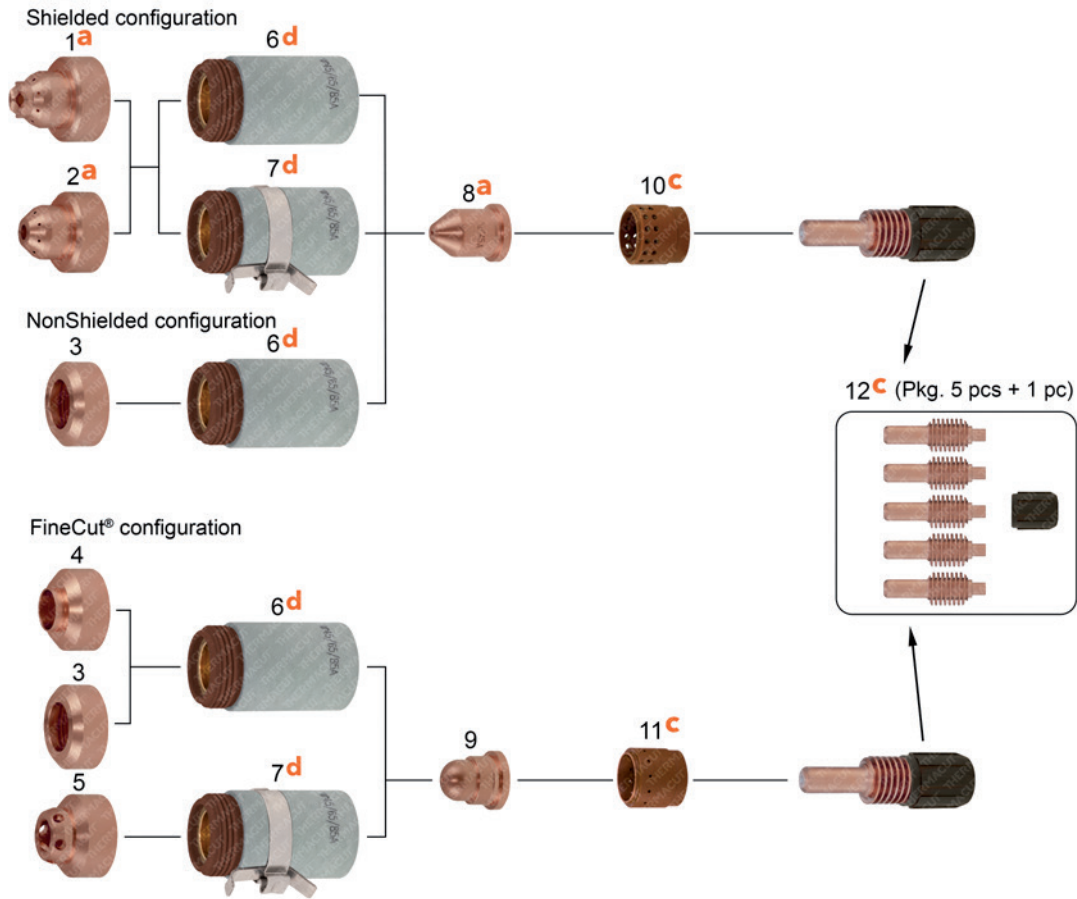

Item	Part No.	Ref. No.	Description	Std. Pkg.	Item	Part No.	Ref. No.	Description	Std. Pkg.
a 1.	T-11406	220818-UR	Shield 45/65/85A, Hand	1	c 9.	T-11845	220930	Nozzle 45A, FineCut®	5
a 2.	T-11404	220817-UR	Shield 45/65/85A, Machine	1	c 10.	T-11861	220857-UR	Swirl Ring 45-85A	1
3.	T-11407	220955	Deflector 45/65/85/105A	1	c 11.	T-12015	220947-UR	Swirl Ring 45A, FineCut®	1
4.	T-12013	220931	Deflector 45A, FineCut®	1	12.	T-11883	220842x5	Electrode 45-105A (pkg. 5 pcs.)	1 x 5
5.	T-12014	220948	Shield 45A, Ohmic, FineCut®	1			220842	Part is available in 5pcs. set 220842x5 only	
d 6.	T-11423	220854-UR	Retaining Cap 45/65/85A	1					
d 7.	T-11931	220953-UR	Retaining Cap 45/65/85A, Ohmic	1					
a 8.	T-11378	220941-UR	Nozzle 45A	5					

- a** MUST BE USED ONLY AS A SET OF SHIELD AND NOZZLE, THIS COMPLETE SET IS INTERCHANGEABLE AND COMPATIBLE WITH ORIGINAL PARTS.
- c** MUST BE USED ONLY AS A SET OF SWIRL RING AND ELECTRODE, THIS COMPLETE SET IS COMPATIBLE WITH ORIGINAL TORCH BODY.
- d** RETAINING CAP UP TO 85A. FOR 105A - RETAINING CAP T-11422 HAS TO BE USED. DIFFERENT RETAINING CAP HAS TO BE USED FOR 105A AND FOR 45/65/85A. ELECTRODES ARE PACKED TOGETHER WITH SWIRL RING SPRING HOLDER (BLACK PART) IN RATIO 5 ELECTRODES TO 1 HOLDER.

THERMACUT®, FHT-EX® AND EX-TRAFIRE® ARE REGISTERED TRADEMARKS OF THERMACUT, K. S. AND MAY BE REGISTERED IN CZECH REPUBLIC AND/OR OTHER COUNTRIES. ALL OTHER TRADEMARKS ARE PROPERTIES OF THEIR RESPECTIVE OWNERS. THERMACUT IS NO WAY AFFILIATED WITH HYPERTHERM®. MOST THERMACUT PARTS ARE MADE FOR OR BY AN IBG COMPANY. PARTS INDICATED WITH A OEM ARE ORIGINAL PARTS MANUFACTURED BY THE ABOVE NAMED MANUFACTURER AND ARE BEING RESOLD BY THERMACUT. THERMACUT RESERVES THE RIGHT TO SUBSTITUTE OEM PARTS IN PLACE OF THERMACUT PARTS. VALID FROM SEPTEMBER 2024 • PREVIOUS VERSION IS NO LONGER VALID. • © COPYRIGHT 2024 BY THERMACUT® CZECH REPUBLIC. ALL RIGHTS RESERVED.

- This page intentionally left blank -

THERMACUT® REPLACEMENT PARTS SUITABLE FOR
Hypertherm®
POWERMAX® 65 / POWERMAX® 85 / POWERMAX® 105
DURAMAX® HAND TORCH, DURAMAX® MACHINE TORCH

45/65/85A application

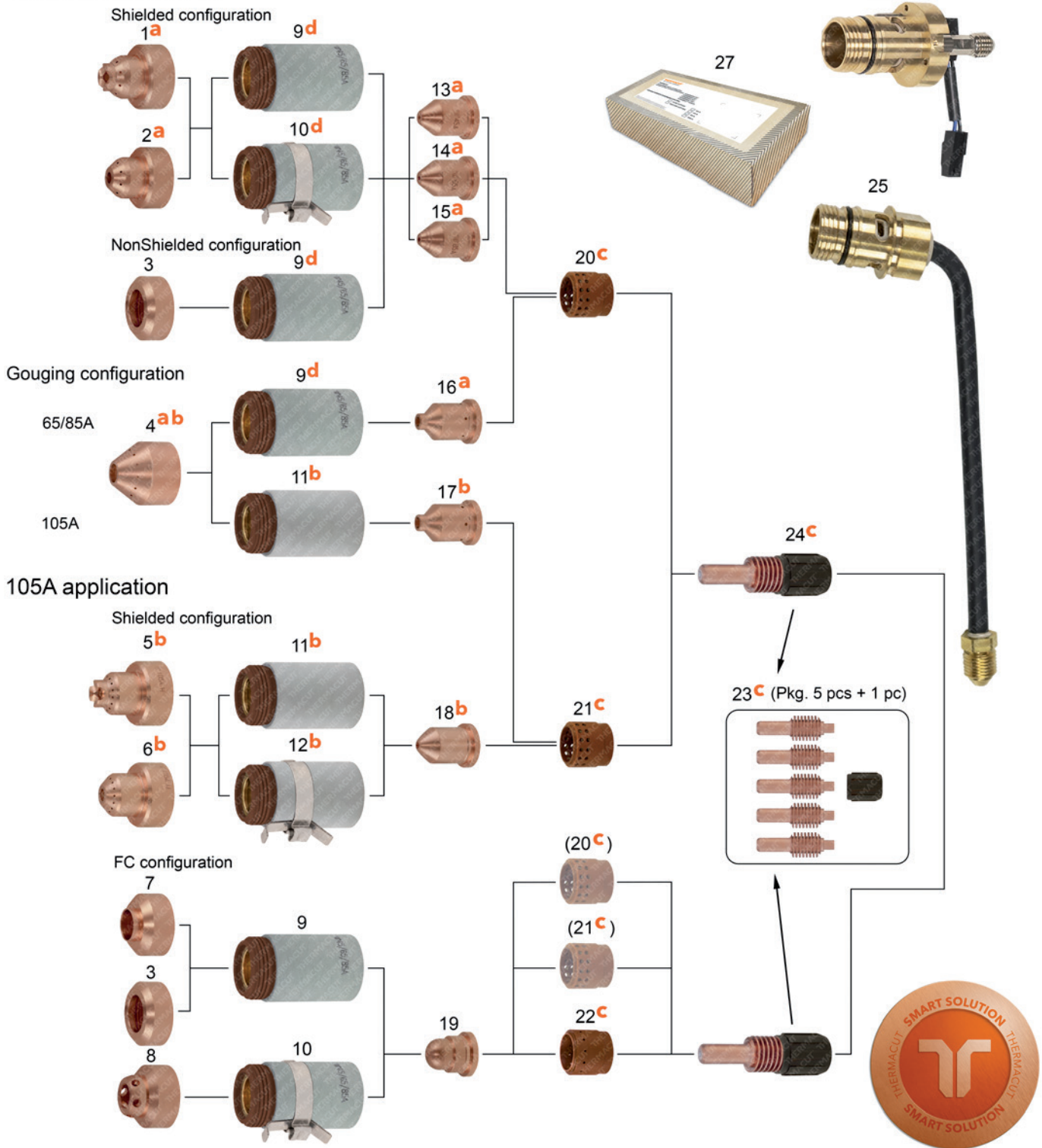

THERMACUT®, FHT-EX® AND EX-TRAFIRE® ARE REGISTERED TRADEMARKS OF THERMACUT, K. S. AND MAY BE REGISTERED IN CZECH REPUBLIC AND/OR OTHER COUNTRIES. ALL OTHER TRADEMARKS ARE PROPERTIES OF THEIR RESPECTIVE OWNERS. THERMACUT IS NO WAY AFFILIATED WITH HYPERTHERM®. MOST THERMACUT PARTS ARE MADE FOR OR BY AN IBG COMPANY. PARTS INDICATED WITH A OEM ARE ORIGINAL PARTS MANUFACTURED BY THE ABOVE NAMED MANUFACTURER AND ARE BEING RESOLD BY THERMACUT. THERMACUT RESERVES THE RIGHT TO SUBSTITUTE OEM PARTS IN PLACE OF THERMACUT PARTS. VALID FROM SEPTEMBER 2024 • PREVIOUS VERSION IS NO LONGER VALID. • © COPYRIGHT 2024 BY THERMACUT® CZECH REPUBLIC. ALL RIGHTS RESERVED.

THERMACUT® REPLACEMENT PARTS SUITABLE FOR
Hypertherm®
POWERMAX® 65 / POWERMAX® 85 / POWERMAX® 105
DURAMAX® HAND TORCH, DURAMAX® MACHINE TORCH



PRODUCT BROCHURE WITH DETAILS AT
WWW.THERMACUT.COM

Item	Part No.	Ref. No.	Description	Std. Pkg.	Item	Part No.	Ref. No.	Description	Std. Pkg.
a 1.	T-11406	220818-UR	Shield 45/65/85A, Hand	1	19.	T-11845	220930	Nozzle 45A, FC	5
a 2.	T-11404	220817-UR	Shield 45/65/85A, Machine	1	C 20.	T-11861	220857-UR	Swirl Ring 45-85A	1
3.	T-11407	220955	Deflector 45/65/85/105A	1	C 21.	T-11930	220994-UR	Swirl Ring 105A	1
ab 4.	T-12022	220798-UR	Shield 65/85/105A, Gouging	1	C 22.	T-12015	220947-UR	Swirl Ring 45A, FC	1
b 5.	T-11841	220992-UR	Shield 105A, Hand	1	C 23.	T-11883	220842x5	Electrode 45-105A (pkg. 5 pcs.)	1 x 5
b 6.	T-11842	220993-UR	Shield 105A, Machine	1		220842		Part is available in 5pcs. set 220842x5 only	
7.	T-12013	220931	Deflector 45A, FC	1	C 24.	T-11862	T-11862	Swirl Ring Holder	1
8.	T-12014	220948	Shield 45A, Ohmic, FC	1	25.	T-12233	228958	Hand Torch Body	1
d 9.	T-11423	220854-UR	Retaining Cap 45/65/85A	1	26.	T-12256	228716	Machine Torch Body	1
d 10.	T-11931	220953-UR	Retaining Cap 45/65/85A, Ohmic	1	**27.	T-11933**	T-11933	Starter Kit 45A, Hand	1
b 11.	T-11422	T-11422	Retaining Cap 105A	1	**	T-11934**	T-11934	Starter Kit 45A, Machine	1
b 12.	T-11932	T-11932	Retaining Cap 105A, Ohmic	1	**	T-11935**	T-11935	Starter Kit 65A, Hand	1
a 13.	T-11378	220941-UR	Nozzle 45A	5	**	T-11936**	T-11936	Starter Kit 65A, Machine	1
a 14.	T-11377	220819-UR	Nozzle 65A	5	**	T-11937**	T-11937	Starter Kit 85A, Hand	1
a 15.	T-11405	220816-UR	Nozzle 85A	5	**	T-11938**	T-11938	Starter Kit 85A, Machine	1
a 16.	T-12021	220797-UR	Nozzle 65/85A, Gouging	5	**	T-11939**	T-11939	Starter Kit 105A, Hand	1
b 17.	T-12023	220991-UR	Nozzle 105A, Gouging	5	**	T-11940**	T-11940	Starter Kit 105A, Machine	1
b 18.	T-11840	220990-UR	Nozzle 105A	5	**	T-11941**	T-11941	Empty box for Starter Kit, universal	1

a MUST BE USED ONLY AS A SET OF SHIELD AND NOZZLE, THIS COMPLETE SET IS INTERCHANGEABLE AND COMPATIBLE WITH ORIGINAL PARTS.

b MUST BE USED ONLY AS A SET OF SHIELD, RETAINING CAP AND NOZZLE, THIS COMPLETE SET IS INTERCHANGEABLE AND COMPATIBLE WITH ORIGINAL PARTS.

c MUST BE USED ONLY AS A SET OF ELECTRODE AND SWIRL RING, THIS COMPLETE SET IS INTERCHANGEABLE AND COMPATIBLE WITH ORIGINAL PARTS. ELECTRODES ARE PACKED TOGETHER WITH SWIRL RING SPRING HOLDER (BLACK PART) IN RATIO 5 ELECTRODES TO 1 HOLDER.

d RETAINING CAP UP TO 85A. FOR 105A - RETAINING CAP T-11422 HAS TO BE USED. DIFFERENT RETAINING CAP HAS TO BE USED FOR 105A AND FOR 45/65/85A.

** CONTENT: ELECTRODE 5 PCS (PACKED TOGETHER WITH SWIRL RING SPRING HOLDER), NOZZLE 5 PCS, SW. RING 1 PC, RET. CAP 1 PC, SHIELD 2 PCS (2**C**), (2**C**) - ALSO POSSIBLE TO USE WITH FC CONFIGURATION, BUT FOR BEST CUT QUALITY RESULTS - USE 220947-UR

SMART SOLUTION - DESIGN IMPROVEMENTS THAT BRINGS ADDED VALUE SUCH AS IMPROVED LIFETIME OF CONSUMABLES, EXCELLENT CUT QUALITY, SPEED OR BETTER COST EFFECTIVENESS OF YOUR SYSTEM.

THERMACUT®, FHT-EX® AND EX-TRAFIRE® ARE REGISTERED TRADEMARKS OF THERMACUT, K. S. AND MAY BE REGISTERED IN CZECH REPUBLIC AND/OR OTHER COUNTRIES. ALL OTHER TRADEMARKS ARE PROPERTIES OF THEIR RESPECTIVE OWNERS. THERMACUT IS NO WAY AFFILIATED WITH HYPERTHERM®. MOST THERMACUT PARTS ARE MADE FOR OR BY AN IBG COMPANY. PARTS INDICATED WITH A OEM ARE ORIGINAL PARTS MANUFACTURED BY THE ABOVE NAMED MANUFACTURER AND ARE BEING RESOLD BY THERMACUT. THERMACUT RESERVES THE RIGHT TO SUBSTITUTE OEM PARTS IN PLACE OF THERMACUT PARTS. VALID FROM SEPTEMBER 2024 • PREVIOUS VERSION IS NO LONGER VALID. • © COPYRIGHT 2024 BY THERMACUT® CZECH REPUBLIC. ALL RIGHTS RESERVED.

THERMACUT® REPLACEMENT PARTS SUITABLE FOR
Hypertherm®
POWERMAX® 65 / POWERMAX® 85 / POWERMAX® 105
DURAMAX® HAND TORCH, DURAMAX® MACHINE TORCH

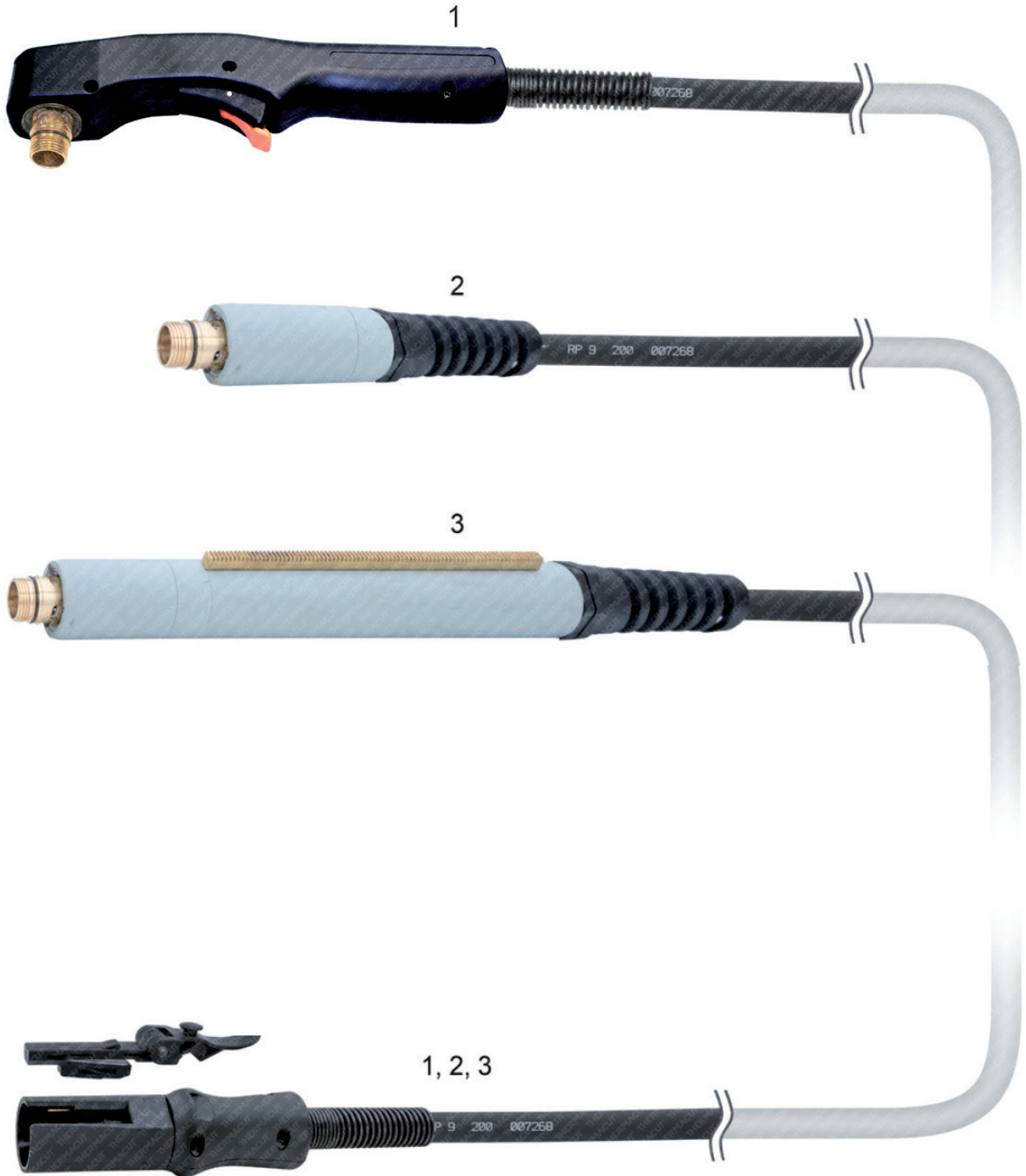

THERMACUT®, FHT-EX® AND EX-TRAFIRE® ARE REGISTERED TRADEMARKS OF THERMACUT, K. S. AND MAY BE REGISTERED IN CZECH REPUBLIC AND/OR OTHER COUNTRIES. ALL OTHER TRADEMARKS ARE PROPERTIES OF THEIR RESPECTIVE OWNERS. THERMACUT IS NO WAY AFFILIATED WITH HYPERTHERM®. MOST THERMACUT PARTS ARE MADE FOR OR BY AN IBG COMPANY. PARTS INDICATED WITH A OEM ARE ORIGINAL PARTS MANUFACTURED BY THE ABOVE NAMED MANUFACTURER AND ARE BEING RESOLD BY THERMACUT. THERMACUT RESERVES THE RIGHT TO SUBSTITUTE OEM PARTS IN PLACE OF THERMACUT PARTS. VALID FROM SEPTEMBER 2024 • PREVIOUS VERSION IS NO LONGER VALID. • © COPYRIGHT 2024 BY THERMACUT® CZECH REPUBLIC. ALL RIGHTS RESERVED.

**THERMACUT® REPLACEMENT PARTS SUITABLE FOR
Hypertherm®
POWERMAX® 65 / POWERMAX® 85 / POWERMAX® 105
DURAMAX® HAND TORCH, DURAMAX® MACHINE TORCH**



PRODUCT BROCHURE WITH DETAILS AT
WWW.THERMACUT.COM

Item	Part No.	Ref. No.	Description	Std. Pkg.	Item	Part No.	Ref. No.	Description	Std. Pkg.
1.	KT-1513	059473-UR	DURAMAX® Hand Torch with Leads 7.6m (25')	1		T-13076	059484-UR	DURAMAX® Mach. Torch Short with Leads 15.2m (50')	1
	KT-1514	059474-UR	DURAMAX® Hand Torch with Leads 15.2m (50')	1	3.	KT-1517	059476-UR	DURAMAX® Machine Torch with Leads 4.6m (15')	1
	KT-1515	059475-UR	DURAMAX® Hand Torch with Leads 23m (75')	1		KT-1518	059477-UR	DURAMAX® Machine Torch with Leads 7.6m (25')	1
2.	T-13073	059481-UR	DURAMAX® Mach. Torch Short with Leads 4.6m (15')	1		KT-1519	059478-UR	DURAMAX® Machine Torch with Leads 10.7m (35')	1
	T-13074	059482-UR	DURAMAX® Mach. Torch Short with Leads 7.6m (25')	1		KT-1520	059479-UR	DURAMAX® Machine Torch with Leads 15.2m (50')	1
	T-13075	059483-UR	DURAMAX® Mach. Torch Short with Leads 10.7m (35')	1		KT-1521	059480-UR	DURAMAX® Machine Torch with Leads 23m (75')	1

THERMACUT®, FHT-EX® AND EX-TRAFIRE® ARE REGISTERED TRADEMARKS OF THERMACUT, K. S. AND MAY BE REGISTERED IN CZECH REPUBLIC AND/OR OTHER COUNTRIES. ALL OTHER TRADEMARKS ARE PROPERTIES OF THEIR RESPECTIVE OWNERS. THERMACUT IS NO WAY AFFILIATED WITH HYPERTHERM®. MOST THERMACUT PARTS ARE MADE FOR OR BY AN IBG COMPANY. PARTS INDICATED WITH A OEM ARE ORIGINAL PARTS MANUFACTURED BY THE ABOVE NAMED MANUFACTURER AND ARE BEING RESOLD BY THERMACUT. THERMACUT RESERVES THE RIGHT TO SUBSTITUTE OEM PARTS IN PLACE OF THERMACUT PARTS.
VALID FROM SEPTEMBER 2024 • PREVIOUS VERSION IS NO LONGER VALID. • © COPYRIGHT 2024 BY THERMACUT® CZECH REPUBLIC. ALL RIGHTS RESERVED.

THERMACUT® REPLACEMENT PARTS SUITABLE FOR
Hypertherm®
POWERMAX® 125 | DURAMAX® HYAMP™

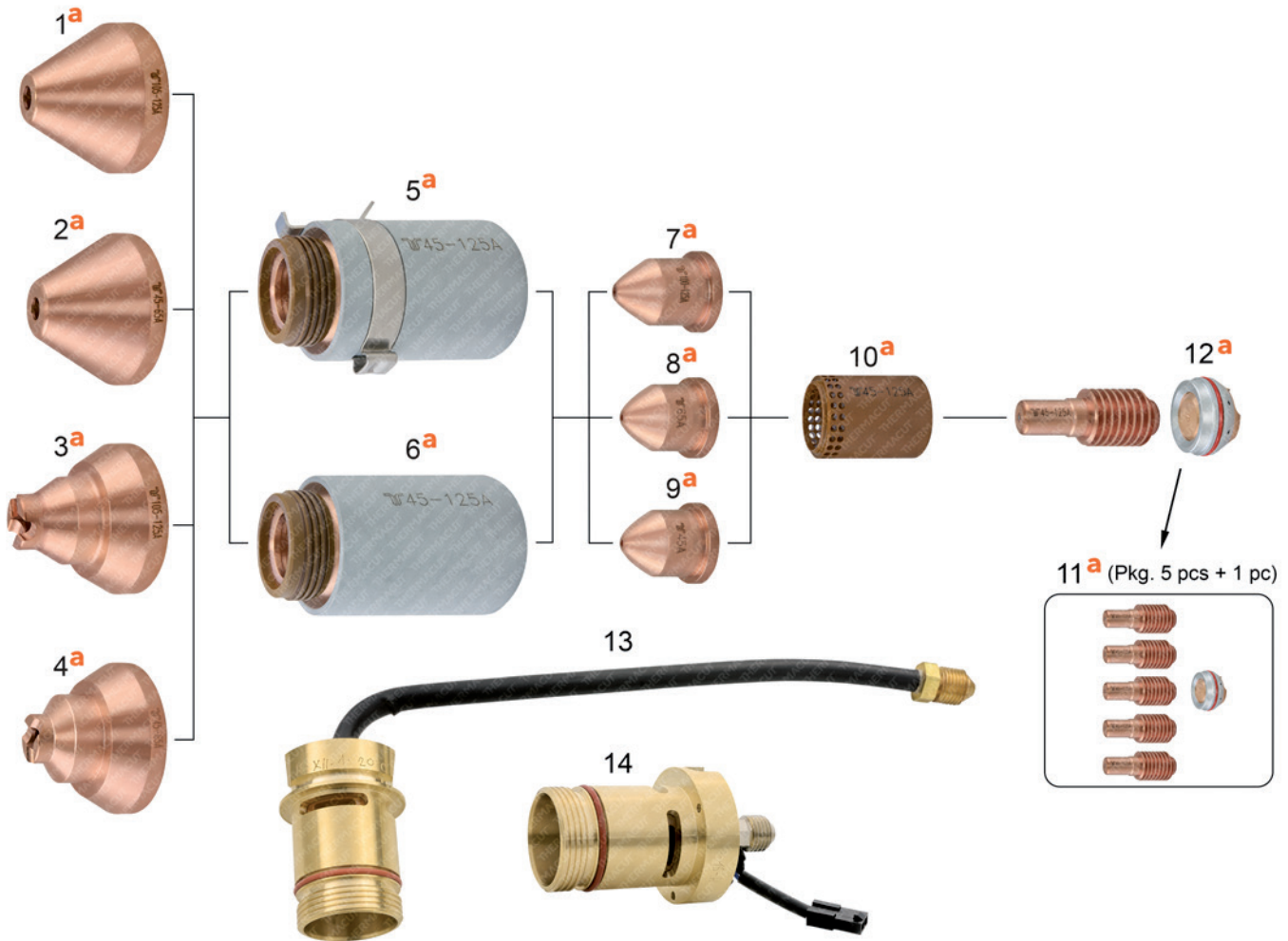

Item	Part No.	Ref. No.	Description	Std. Pkg.	Item	Part No.	Ref. No.	Description	Std. Pkg.
a 1.	T-13267	220976-UR	Shield 105-125A, Machine	1	a 8.	T-13269	420169-UR	Nozzle 65A	5
a 2.	T-13270	420168-UR	Shield 45-65A, Machine	1	a 9.	T-13312	420158-UR	Nozzle 45A	5
a 3.	T-13271	420000-UR	Shield 105-125A, Hand	1	a NS	T-13335	420151-UR	Nozzle 30-45A, FC	5
a 4.	T-13272	420172-UR	Shield 45-65A, Hand	1	a NS	T-13333	420001-UR	Nozzle 65-125A, Gouging	5
a NS	T-13336	420152-UR	Shield 30-45A, FC	1	a 10.	T-13268	220997-UR	Swirl Ring 45-125A	1
a NS	T-13334	420112-UR	Shield 65-125A, Gouging Max Remove	1	a 11.	T-13304	220971x5	Electrode 45-125A (pkg. 5 pcs.)	1 x 5
a NS	T-13338	420509-UR	Shield 30-125A, Gouging Max Control	1			220971	Part is available in 5pcs. set 220971x5 only.	
a 5.	T-13276	420156-UR	Retaining Cap 45-125A IHS	1	a 12.	T-13275	T-13275	Swirl Ring Holder	1
a 6.	T-13273	220977-UR	Retaining Cap 45-125A	1	13.	T-13293	428158	Torch Body, Hand DMX125H	1
a 7.	T-13266	220975-UR	Nozzle 105-125A	5	14.	T-13292	428147	Torch Body, Machine DMX125M	1

a MUST BE USED ONLY AS A SET OF ALL PARTS, THIS COMPLETE SET CAN BE USED INTO ORIGINAL TORCH BODY.
NS NOT SHOWN IN THE PICTURE

THERMACUT®, FHT-EX® AND EX-TRAFIRE® ARE REGISTERED TRADEMARKS OF THERMACUT, K. S. AND MAY BE REGISTERED IN CZECH REPUBLIC AND/OR OTHER COUNTRIES. ALL OTHER TRADEMARKS ARE PROPERTIES OF THEIR RESPECTIVE OWNERS. THERMACUT IS NO WAY AFFILIATED WITH HYPERTHERM®. MOST THERMACUT PARTS ARE MADE FOR OR BY AN IBG COMPANY. PARTS INDICATED WITH A OEM ARE ORIGINAL PARTS MANUFACTURED BY THE ABOVE NAMED MANUFACTURER AND ARE BEING RESOLD BY THERMACUT. THERMACUT RESERVES THE RIGHT TO SUBSTITUTE OEM PARTS IN PLACE OF THERMACUT PARTS.
 VALID FROM SEPTEMBER 2024 • PREVIOUS VERSION IS NO LONGER VALID. • © COPYRIGHT 2024 BY THERMACUT® CZECH REPUBLIC. ALL RIGHTS RESERVED.

THERMACUT® REPLACEMENT PARTS SUITABLE FOR
Hypertherm®
POWERMAX® 125 | DURAMAX® HYAMP™ TORCHES AND CABLE LEADS

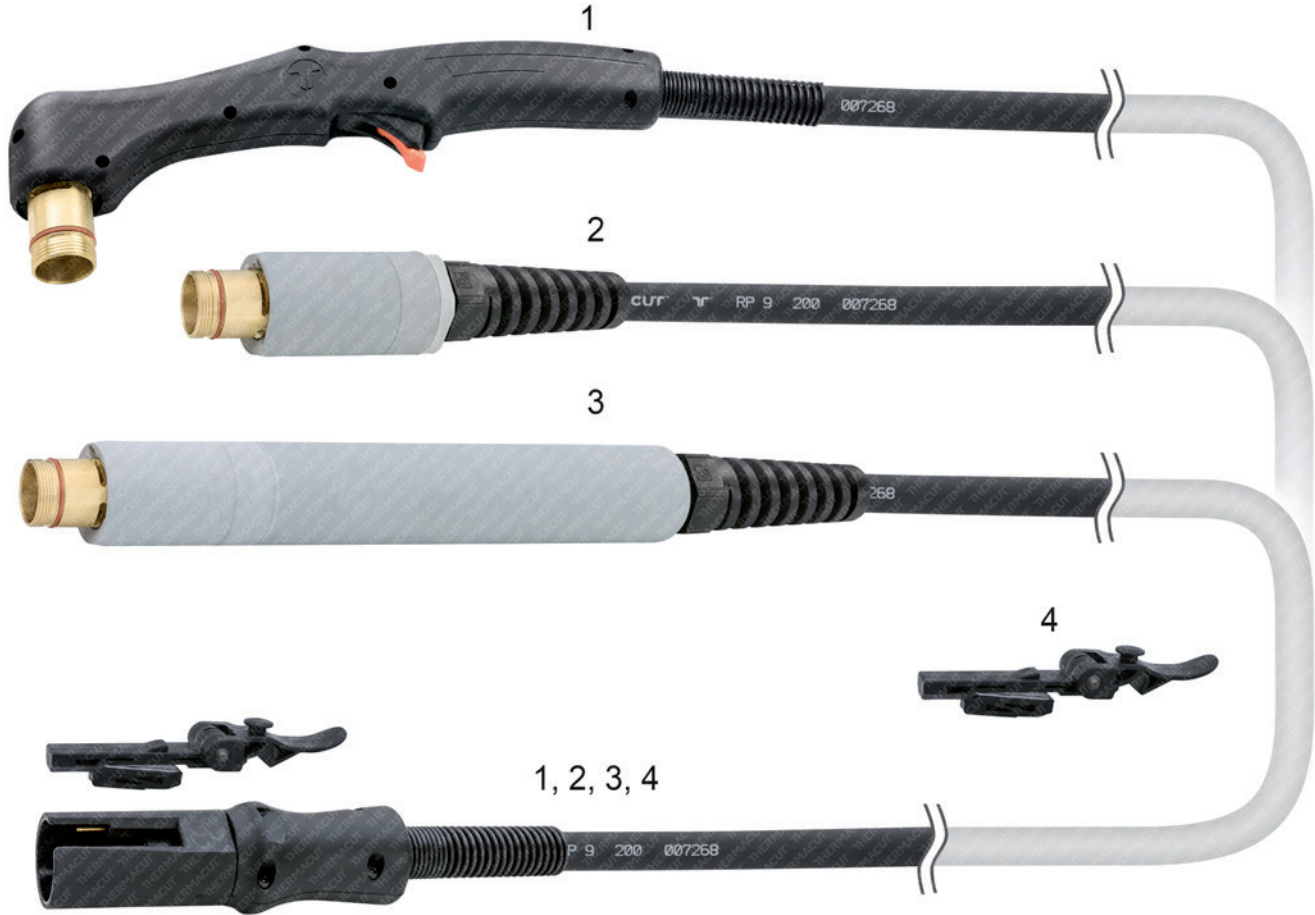

Item	Part No.	Ref. No.	Description	Std. Pkg.
1.	T-13302	059492-UR	DURAMAX® HyAmp™ Hand Torch with Leads 7.6m (25')	1
	T-13314	059493-UR	DURAMAX® HyAmp™ Hand Torch with Leads 15m (50')	1
	T-13315	059494-UR	DURAMAX® HyAmp™ Hand Torch with Leads 23m (75')	1
!!!	T-13341	DEMO DMX125H	DURAMAX® HyAmp™ Hand Torch with Leads 0.8m, sample piece - exhibition only	1
2.	T-13325	059514-UR	DURAMAX® HyAmp™ Mini Machine Torch with Leads 4.6m (15')	1
	T-13326	059515-UR	DURAMAX® HyAmp™ Mini Machine Torch with Leads 7.6m (25')	1
	T-13327	059516-UR	DURAMAX® HyAmp™ Mini Machine Torch with Leads 10.7m (35')	1
	T-13328	059517-UR	DURAMAX® HyAmp™ Mini Machine Torch with Leads 15m (50')	1
!!!	T-13343	DEMO DMX125MM	DURAMAX® HyAmp™ Mini Machine Torch with Leads 0.8m, sample piece - exhibition only	1
3.	T-13303	059520-UR	DURAMAX® HyAmp™ Machine Torch with Leads 7.6m (25')	1
	T-13316	059519-UR	DURAMAX® HyAmp™ Machine Torch with Leads 4.6m (15')	1
	T-13317	059521-UR	DURAMAX® HyAmp™ Machine Torch with Leads 10.7m (35')	1
	T-13318	059522-UR	DURAMAX® HyAmp™ Machine Torch with Leads 15m (50')	1
	T-13319	059523-UR	DURAMAX® HyAmp™ Machine Torch with Leads 23m (75')	1
!!!	T-13342	DEMO DMX125M	DURAMAX® HyAmp™ Machine Torch with Leads 0.8m, sample piece - exhibition only	1
4.	PT-13221	PT-13221	Latch and Key	1

!!! DEMO IS INOPERATIVE, FOR EXHIBITION PURPOSES ONLY!

THERMACUT®, FHT-EX® AND EX-TRAIFIRE® ARE REGISTERED TRADEMARKS OF THERMACUT, K. S. AND MAY BE REGISTERED IN CZECH REPUBLIC AND/OR OTHER COUNTRIES. ALL OTHER TRADEMARKS ARE PROPERTIES OF THEIR RESPECTIVE OWNERS. THERMACUT IS NO WAY AFFILIATED WITH HYPERTHERM®. MOST THERMACUT PARTS ARE MADE FOR OR BY AN IBC COMPANY. PARTS INDICATED WITH A OEM ARE ORIGINAL PARTS MANUFACTURED BY THE ABOVE NAMED MANUFACTURER AND ARE BEING RESOLD BY THERMACUT. THERMACUT RESERVES THE RIGHT TO SUBSTITUTE OEM PARTS IN PLACE OF THERMACUT PARTS. VALID FROM SEPTEMBER 2024 • PREVIOUS VERSION IS NO LONGER VALID. • © COPYRIGHT 2024 BY THERMACUT® CZECH REPUBLIC. ALL RIGHTS RESERVED.

THERMACUT® REPLACEMENT PARTS SUITABLE FOR
Hypertherm®
HT® 2000 HySpeed® | PAC® 200/T

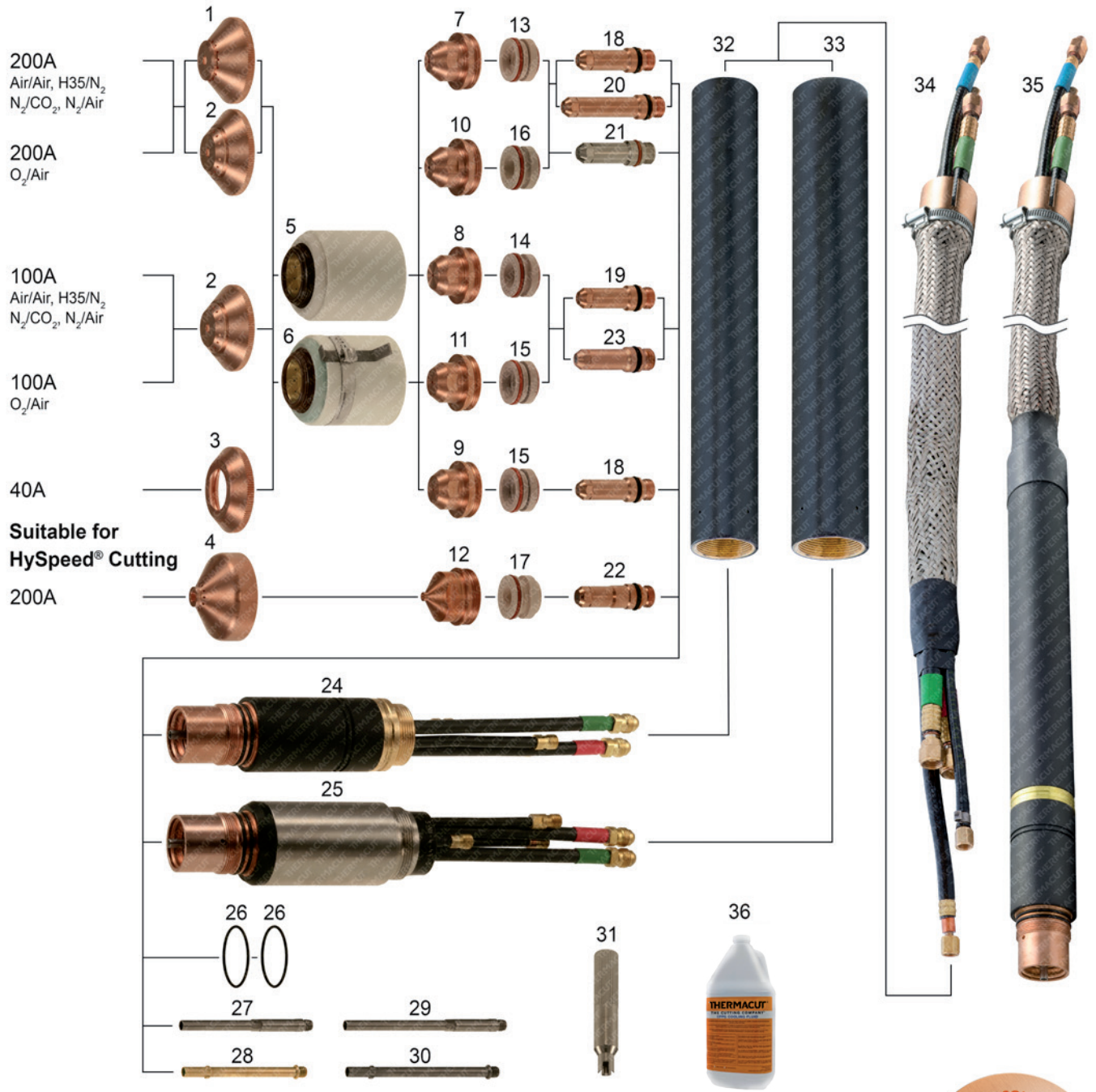

Parts for HyPro™ / MaxPro™ line of HT2000® also available; see other pages for details.



THERMACUT®, FHT-EX® AND EX-TRAFIRE® ARE REGISTERED TRADEMARKS OF THERMACUT, K. S. AND MAY BE REGISTERED IN CZECH REPUBLIC AND/OR OTHER COUNTRIES. ALL OTHER TRADEMARKS ARE PROPERTIES OF THEIR RESPECTIVE OWNERS. THERMACUT IS NO WAY AFFILIATED WITH HYPERTHERM®. MOST THERMACUT PARTS ARE MADE FOR OR BY AN IBG COMPANY. PARTS INDICATED WITH A OEM ARE ORIGINAL PARTS MANUFACTURED BY THE ABOVE NAMED MANUFACTURER AND ARE BEING RESOLD BY THERMACUT. THERMACUT RESERVES THE RIGHT TO SUBSTITUTE OEM PARTS IN PLACE OF THERMACUT PARTS. VALID FROM SEPTEMBER 2024 • PREVIOUS VERSION IS NO LONGER VALID. • © COPYRIGHT 2024 BY THERMACUT® CZECH REPUBLIC. ALL RIGHTS RESERVED.

THERMACUT® REPLACEMENT PARTS SUITABLE FOR
Hypertherm®
HT®2000 HySpeed® | PAC®200/T

Item	Part No.	Ref. No.	Description	Std. Pkg.	Item	Part No.	Ref. No.	Description	Std. Pkg.
1.	T-4463	020424-UR	Shield 200A, Machine	1	21.	T-4901	020664-AG	Electrode 40A, 200A, SilverEX-®	5
2.	T-0365	020424	Shield 200A, Machine	1	*22.	T-10261*	220235-UR	Electrode HySpeed® 200A	5
	T-0366	020448	Shield 100A, Machine	1	*23.	T-0382*	020415-UR	Electrode 100-200A	5
3.	T-0368	020688	Shield 40A, Machine	1	24.	T-9757	120584	MAX®200/HT®2000, Machine Torch (same as 020470)	1
NS	T-10317	120260-UR	Shield 200A, Bevel, O ₂ /Air	1	25.	T-4066	120356	MAX®200/HT®2000, S.S. Machine Torch	1
4.	T-4462	220239-UR	Shield HySpeed® 200A	1	26.	T-0383	044027	O-Ring	1
5.	T-0370	020423	Retaining Cap	1	#27.	T-1813	020963	Water Tube, OEM Torch	1
6.	T-10242	120837	Retaining Cap, Ohmic	1	**28.	T-4119	T-4119	Water Tube, TMT/OEM Torch	1
7.	T-0372	020608	Nozzle 200A	5	*29.	T-10876	120257	Water Tube, Extended, OEM Torch	1
8.	T-0373	020611	Nozzle 100A	5	**30.	PT-11557	T-4120	Water Tube, Extended, TMT/OEM Torch	1
9.	T-0376	020689	Nozzle 40A	5	31.	T-1397	T-1397	Wrench for TMT Water Tube	1
10.	T-0371	020605	Nozzle 200A, O ₂	5	32.	T-0386	020431	Sleeve 1.75" (D 44.5mm for 120584 or 020470)	1
11.	T-1045	020690	Nozzle 100A	5	33.	T-1001	020041	Sleeve 2" (D 50.8mm for 120356)	1
NS	T-2839	120259	Nozzle 200A, Bevel, O ₂ /Air	1	34.	T-13249	T-13249	HT®2000 Cable Leads 4.6m (15')	1
12.	T-8860	220237	Nozzle HySpeed® 200A	1		KT-1412	028659	HT®2000 Cable Leads 6.1m (20')	1
13.	T-1047	020679	Swirl Ring 200A	1		KT-1213	028546	HT®2000 Cable Leads 7.6m (25')	1
14.	T-0378	020607	Swirl Ring 100A	1		KT-1085	028662	HT®2000 Cable Leads 12.2m (40')	1
15.	T-0379	020613	Swirl Ring 40A, 100A	1		KT-1081	028547	HT®2000 Cable Leads 15.2m (50')	1
16.	T-1046	120833	Swirl Ring 200A, O ₂	1	35.	Cable with torch available on request.			
OD	T-10945	120834	Swirl Ring 200A, O ₂ , CCW	5	36.	Coolant Liquid. Details on the Accessories page.			
17.	T-10318	220236	Swirl Ring HySpeed® 200A	1	Different types of cable leads available on request				
18.	T-0998	120667	Electrode 40A, 200A	5	Parts HyPro™/MaxPro™ for line HT®2000 available also, see other pages for details.				
19.	T-0773	120547	Electrode 100A, 200A	5					
20.	T-2838	120258	Electrode 200A, Extended	5					

OD ON DEMAND – WE DO NOT KEEP THESE PARTS IN STOCK, COST IS SET ACCORDING TO THE ORDERED QUANTITY, DELIVERY TIME MAY DIFFER FROM STANDARD PRODUCTS.

COMPATIBLE WITH OEM TORCH ONLY, DOESN'T FIT TO THERMACUT® TORCH

***** FULLY INTERCHANGEABLE WITH ORIGINAL PARTS, BUT DIFFERS FROM ORIGINAL DESIGN

****** COMPATIBLE WITH THERMACUT® AND OEM TORCH

-AG HEAVY DUTY ELECTRODE, OFFERS BETTER LIFETIME

CCW COUNTER CLOCK WISE GAS SWIRLING, USE OF CCW PARTS WILL MAKE CUT ANGLE ON THE OPPOSITE SIDE, THAN WITH STANDARD CLOCK WISE (CW) SWIRLING PARTS.

NS NOT SHOWN IN THE PICTURE

SMART SOLUTION – DESIGN IMPROVEMENTS THAT BRINGS ADDED VALUE SUCH AS IMPROVED LIFETIME OF CONSUMABLES, EXCELLENT CUT QUALITY, SPEED OR BETTER COST EFFECTIVENESS OF YOUR SYSTEM.

THERMACUT®, FHT-EX® AND EX-TRAFIRE® ARE REGISTERED TRADEMARKS OF THERMACUT, K. S. AND MAY BE REGISTERED IN CZECH REPUBLIC AND/OR OTHER COUNTRIES. ALL OTHER TRADEMARKS ARE PROPERTIES OF THEIR RESPECTIVE OWNERS. THERMACUT IS NO WAY AFFILIATED WITH HYPERTHERM®. MOST THERMACUT PARTS ARE MADE FOR OR BY AN IBG COMPANY. PARTS INDICATED WITH A OEM ARE ORIGINAL PARTS MANUFACTURED BY THE ABOVE NAMED MANUFACTURER AND ARE BEING RESOLD BY THERMACUT. THERMACUT RESERVES THE RIGHT TO SUBSTITUTE OEM PARTS IN PLACE OF THERMACUT PARTS. VALID FROM SEPTEMBER 2024 • PREVIOUS VERSION IS NO LONGER VALID. • © COPYRIGHT 2024 BY THERMACUT® CZECH REPUBLIC. ALL RIGHTS RESERVED.

**THERMACUT® REPLACEMENT PARTS SUITABLE FOR
Hypertherm®
HyPro™2000 UPGRADE TORCH
FOR HT®2000 MILD STEEL, STAINLESS STEEL, ALUMINIUM**

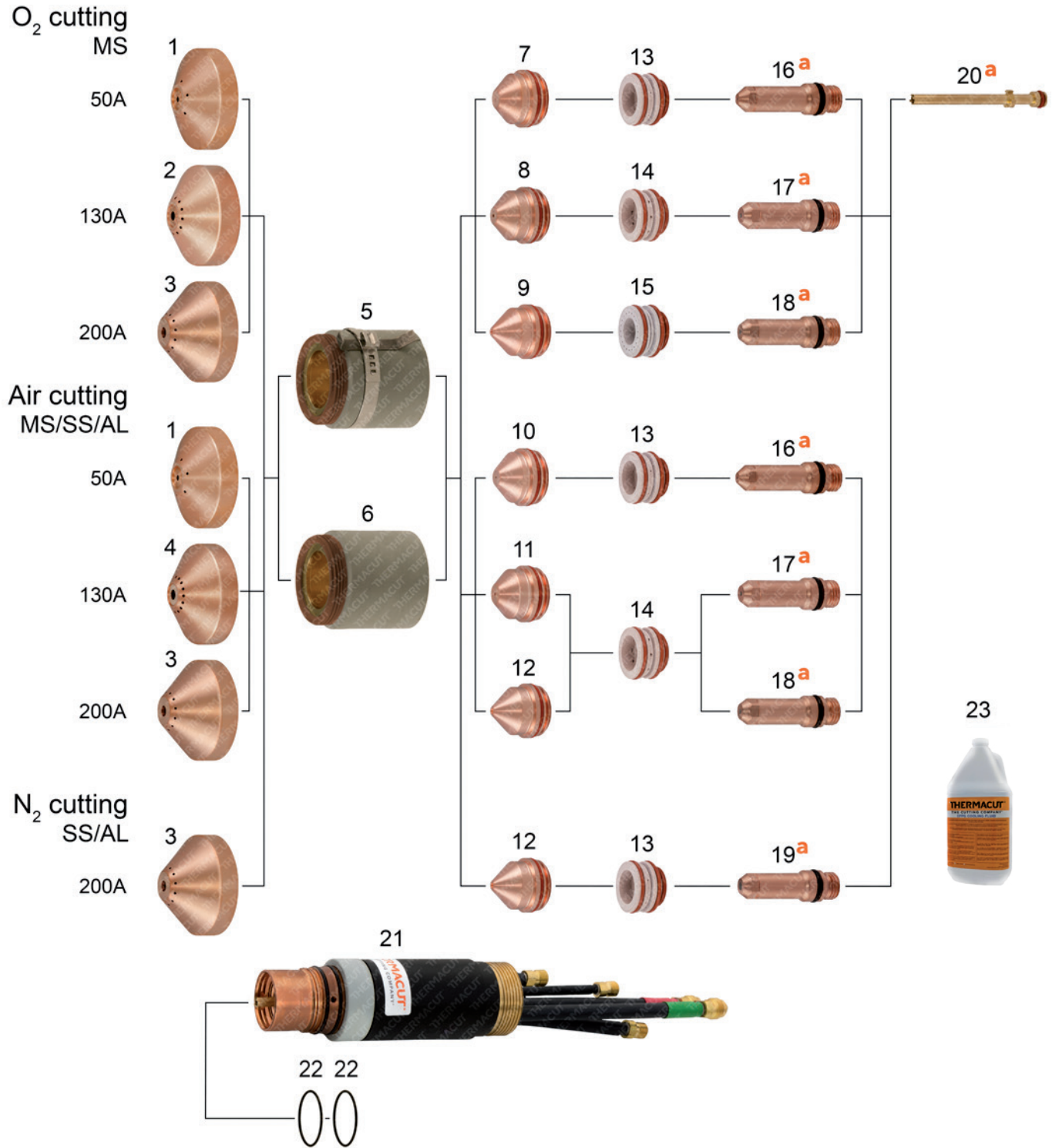

Parts for HyPro™ / MaxPro™ line of Max200® also available; see other pages for details

THERMACUT®, FHT-EX® AND EX-TRAFIRE® ARE REGISTERED TRADEMARKS OF THERMACUT, K. S. AND MAY BE REGISTERED IN CZECH REPUBLIC AND/OR OTHER COUNTRIES. ALL OTHER TRADEMARKS ARE PROPERTIES OF THEIR RESPECTIVE OWNERS. THERMACUT IS NO WAY AFFILIATED WITH HYPERTHERM®. MOST THERMACUT PARTS ARE MADE FOR OR BY AN IBC COMPANY. PARTS INDICATED WITH A OEM ARE ORIGINAL PARTS MANUFACTURED BY THE ABOVE NAMED MANUFACTURER AND ARE BEING RESOLD BY THERMACUT. THERMACUT RESERVES THE RIGHT TO SUBSTITUTE OEM PARTS IN PLACE OF THERMACUT PARTS. VALID FROM SEPTEMBER 2024 • PREVIOUS VERSION IS NO LONGER VALID. • © COPYRIGHT 2024 BY THERMACUT® CZECH REPUBLIC. ALL RIGHTS RESERVED.

**THERMACUT® REPLACEMENT PARTS SUITABLE FOR
Hypertherm®
HyPro™2000 UPGRADE TORCH
FOR HT®2000 MILD STEEL, STAINLESS STEEL, ALUMINIUM**



PRODUCT BROCHURE WITH DETAILS AT
WWW.THERMACUT.COM

Item	Part No.	Ref. No.	Description	Std. Pkg.	Item	Part No.	Ref. No.	Description	Std. Pkg.
1.	T-11283	220532	Shield 50A, O ₂ /Air	1	13.	T-11282	220529	Swirl Ring 50A, O ₂ /Air (200A, N ₂)	1
2.	T-11281	220491	Shield 130A, O ₂	1	14.	T-11280	220488	Swirl Ring 130A (200A)	1
3.	T-11375	220832	Shield 200A, O ₂ /Air	1	15.	T-11312	220834	Swirl Ring 200A, O ₂	1
4.	T-11284	220536	Shield 130A, Air	1	a 16.	T-11309	220528-UR	Electrode 45A (50A)	5
5.	T-13097	220936	Retaining Cap 50-200A, O ₂ /Air (200A, N ₂), HD	1	a 17.	T-11304	220487-UR	Electrode 130A, O ₂ /Air	5
6.	T-13096	220935	Retaining Cap 50-200A, O ₂ /Air (200A, N ₂), w/o IHS, HD	1	a 18.	T-11317	220937-UR	Electrode 200A, O ₂ /Air	5
NS	T-13094	220490	Retaining Cap 45/130A, Air (50/130A, O ₂), w/o IHS, HD	1	a 19.	T-0382	020415-UR	Electrode 100-200A	5
NS	T-13095	220578	Retaining Cap 45/130A, Air (50/130A, O ₂), with IHS, HD	1	a 20.	T-11307	220521-UR	Cooling Tube (use with TMT electrode)	1
7.	T-11314*	220891-UR	Nozzle 50A, O ₂	5	21.	T-12227	220961-UR	HyPro™2000 Machine Torch	1
8.	T-11316*	220893-UR	Nozzle 130A, O ₂	5	22.	N-10094	1-027B	O-Ring	1
9.	T-11836*	220831-UR	Nozzle 200A, O ₂	1	23.	Coolant Liquid. Details on the Accessories page.			
10.	T-11313*	220890-UR	Nozzle 50A, Air	5	Parts HyPro™/MaxPro™ for line MAX®200 available also, see other pages for details.				
11.	T-11315*	220892-UR	Nozzle 130A, O ₂ /Air	5					
12.	T-11837*	420044-UR	Nozzle 200A, O ₂ /Air/N ₂	5					

* FULLY INTERCHANGEABLE WITH ORIGINAL PARTS, BUT DIFFERS FROM ORIGINAL DESIGN

a THERMACUT® ELECTRODES HAS TO BE USED WITH THERMACUT® DESIGN COOLING TUBE, OTHERWISE IT DOESN'T FIT TO THE TORCH, THERMACUT® COOLING TUBE CAN BE USED FOR THERMACUT® DESIGN ELECTRODES AND FOR ORIGINAL DESIGN TOO.

NS NOT SHOWN IN THE PICTURE

W/O WITHOUT

HD HEAVY DUTY - OFFERS HIGHER THERMAL RESISTANCE OF THREAD AREA, WHICH COULD BE DAMAGED DURING PIERCING.

THERMACUT®, FHT-EX® AND EX-TRAFIRE® ARE REGISTERED TRADEMARKS OF THERMACUT, K. S. AND MAY BE REGISTERED IN CZECH REPUBLIC AND/OR OTHER COUNTRIES. ALL OTHER TRADEMARKS ARE PROPERTIES OF THEIR RESPECTIVE OWNERS. THERMACUT IS NO WAY AFFILIATED WITH HYPERTHERM®. MOST THERMACUT PARTS ARE MADE FOR OR BY AN IBG COMPANY. PARTS INDICATED WITH A OEM ARE ORIGINAL PARTS MANUFACTURED BY THE ABOVE NAMED MANUFACTURER AND ARE BEING RESOLD BY THERMACUT. THERMACUT RESERVES THE RIGHT TO SUBSTITUTE OEM PARTS IN PLACE OF THERMACUT PARTS. VALID FROM SEPTEMBER 2024 • PREVIOUS VERSION IS NO LONGER VALID. • © COPYRIGHT 2024 BY THERMACUT® CZECH REPUBLIC. ALL RIGHTS RESERVED.

THERMACUT® REPLACEMENT PARTS SUITABLE FOR
Hypertherm®
MAX® 200 | PAC® 200T/E

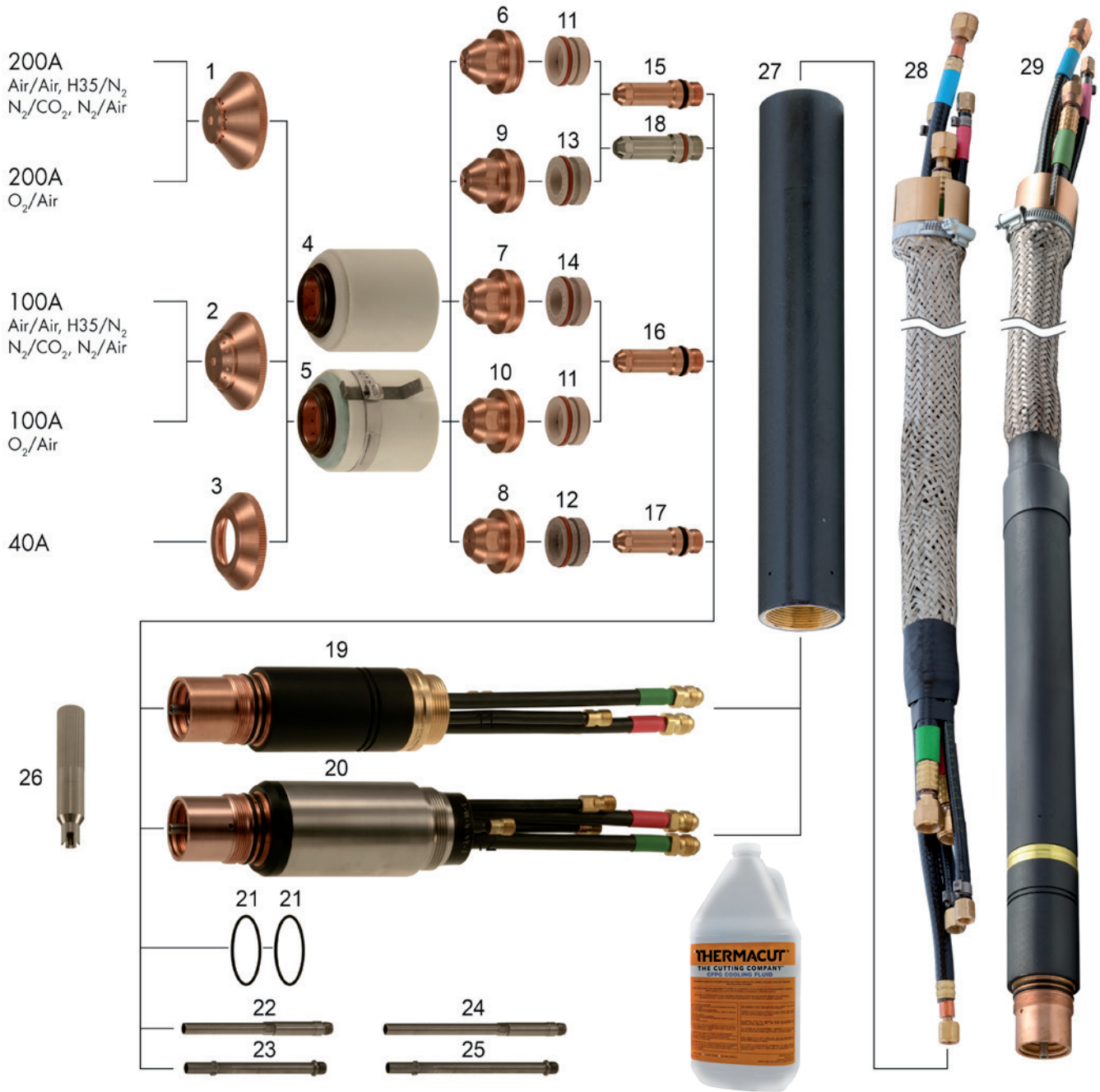

Parts for HyPro™ / MaxPro™ line of Max200® also available; see other pages for details

THERMACUT®, FHT-EX® AND EX-TRAFIRE® ARE REGISTERED TRADEMARKS OF THERMACUT, K. S. AND MAY BE REGISTERED IN CZECH REPUBLIC AND/OR OTHER COUNTRIES. ALL OTHER TRADEMARKS ARE PROPERTIES OF THEIR RESPECTIVE OWNERS. THERMACUT IS NO WAY AFFILIATED WITH HYPERTHERM®. MOST THERMACUT PARTS ARE MADE FOR OR BY AN IBC COMPANY. PARTS INDICATED WITH A OEM ARE ORIGINAL PARTS MANUFACTURED BY THE ABOVE NAMED MANUFACTURER AND ARE BEING RESOLD BY THERMACUT. THERMACUT RESERVES THE RIGHT TO SUBSTITUTE OEM PARTS IN PLACE OF THERMACUT PARTS. VALID FROM SEPTEMBER 2024 • PREVIOUS VERSION IS NO LONGER VALID. • © COPYRIGHT 2024 BY THERMACUT® CZECH REPUBLIC. ALL RIGHTS RESERVED.

THERMACUT® REPLACEMENT PARTS SUITABLE FOR
Hypertherm®
MAX® 200 | PAC® 200T/E

Item	Part No.	Ref. No.	Description	Std. Pkg.	Item	Part No.	Ref. No.	Description	Std. Pkg.
1.	T-0365	020424	Shield 200A, Machine	1	#25.	T-10876	120257	Water Tube, Extended, OEM Torch	1
	T-0366	020448	Shield 100A, Machine	1	**26.	PT-11557	T-4120	Water Tube, Extended, TMT/OEM Torch	1
2.	T-0368	020688	Shield 40A, Machine	1	27.	T-1397	T-1397	Wrench for TMT Water Tube	1
3.	T-0370	020423	Retaining Cap	1	28.	T-0386	020431	Sleeve 1.75" (D 44.5mm for 020470 or 120584)	1
4.	T-10242	120837	Retaining Cap, Ohmic	1	29.	T-1001	020041	Sleeve 2" (D 50.8mm for 120356)	1
5.	T-0372	020608	Nozzle 200A	5	30.	T-0669	028383	MAX®200 Cable Leads Mach. 7.6m (25')	1
6.	T-0373	020611	Nozzle 100A	5		T-0671	028457	MAX®200 Cable Leads Mach. 9.1m (30')	
7.	T-0376	020689	Nozzle 40A	5		T-0672	028458	MAX®200 Cable Leads Mach. 10.7m (35')	1
8.	T-0371	020605	Nozzle 200A, O ₂	5		T-0673	028459	MAX®200 Cable Leads Mach. 12.2m (40')	1
9.	T-0375	020616	Nozzle 100A, O ₂	5		T-0674	028460	MAX®200 Cable Leads Mach. 13.7 (45')	1
	T-2389	120259	Nozzle, Bevel O ₂	5		T-0670	028384	MAX®200 Cable Leads Mach. 15.2m (50')	1
10.	T-0378	020607	Swirl Ring 100A, 200A	1		KT-1078	K.MAX200.21M.K	MAX®200 Cable Leads Mach. 21m (69')	1
11.	T-0379	020613	Swirl Ring 40A	1		T-2829	028599	MAX®200 Cable Leads Mach. 22.9m (75')	1
12.	T-0377	020604	Swirl Ring 200A, O ₂	1	31.	T-13329	K.MAX200.2,0M	MAX®200 Mach. Torch with Leads 2.0m (6.5')	1
13.	T-0380	020617	Swirl Ring 100A, O ₂	1		KT-1167	K.MAX200.7,6M	MAX®200 Mach. Torch with Leads 7.6m (25')	1
NS	T-1046	120833	Swirl Ring, Bevel, Oxy	1		KT-1059	K.MAX200.10,7M	MAX®200 Mach. Torch with Leads 10.7m (35')	1
14.	T-3926	220021-UR	Electrode 40A, 200A	5		KT-1168	K.MAX200.15,2M	MAX®200 Mach. Torch with Leads 15.2m (50')	1
15.	T-2838	120258	Electrode 200A, Extended	5	!!!	KT-1248	DEMO MAX200	MAX®200 Machine Torch with Leads, sample piece - exhibition only	1
16.	T-0773	120547	Electrode 100A, 200A	5	32.	Coolant Liquid. Details on the Accessories page.			
17.	T-0998	120667	Electrode 40A, 200A	5	Different types of cable leads available on request				
18.	T-4901	020664-AG	Electrode 40A, 200A, SilverEX-®	5	Parts HyPro™/MaxPro™ for line MAX®200 available also, see other pages for details.				
19.	T-0382	020415-UR	Electrode 100-200A	5					
20.	T-0384	020470	MAX®200, Machine Torch (same as 120584)	1					
21.	T-4066	120356	MAX®200/HT®2000, S.S. Machine Torch	1					
22.	T-0383	044027	O-Ring	1					
#23.	T-1813	020963	Water Tube, OEM Torch	1					
**24.	T-4119	T-4119	Water Tube, TMT/OEM Torch	1					

- # COMPATIBLE WITH OEM TORCH ONLY, DOESN'T FIT TO THERMACUT® TORCH
- !!! DEMO IS INOPERATIVE, FOR EXHIBITION PURPOSES ONLY!
- * FULLY INTERCHANGEABLE WITH ORIGINAL PARTS, BUT DIFFERS FROM ORIGINAL DESIGN
- ** COMPATIBLE WITH THERMACUT® AND OEM TORCH
- NS NOT SHOWN IN THE PICTURE
- AG HEAVY DUTY ELECTRODE, OFFERS BETTER LIFETIME

THERMACUT®, FHT-EX® AND EX-TRAFIRE® ARE REGISTERED TRADEMARKS OF THERMACUT, K. S. AND MAY BE REGISTERED IN CZECH REPUBLIC AND/OR OTHER COUNTRIES. ALL OTHER TRADEMARKS ARE PROPERTIES OF THEIR RESPECTIVE OWNERS. THERMACUT IS NO WAY AFFILIATED WITH HYPERTHERM®. MOST THERMACUT PARTS ARE MADE FOR OR BY AN IBG COMPANY. PARTS INDICATED WITH A OEM ARE ORIGINAL PARTS MANUFACTURED BY THE ABOVE NAMED MANUFACTURER AND ARE BEING RESOLD BY THERMACUT. THERMACUT RESERVES THE RIGHT TO SUBSTITUTE OEM PARTS IN PLACE OF THERMACUT PARTS. VALID FROM SEPTEMBER 2024 • PREVIOUS VERSION IS NO LONGER VALID. • © COPYRIGHT 2024 BY THERMACUT® CZECH REPUBLIC. ALL RIGHTS RESERVED.

**THERMACUT® REPLACEMENT PARTS SUITABLE FOR
Hypertherm®
MaxPro™200 UPGRADE TORCH
FOR MAX®200 MILD STEEL, STAINLESS STEEL, ALUMINIUM**

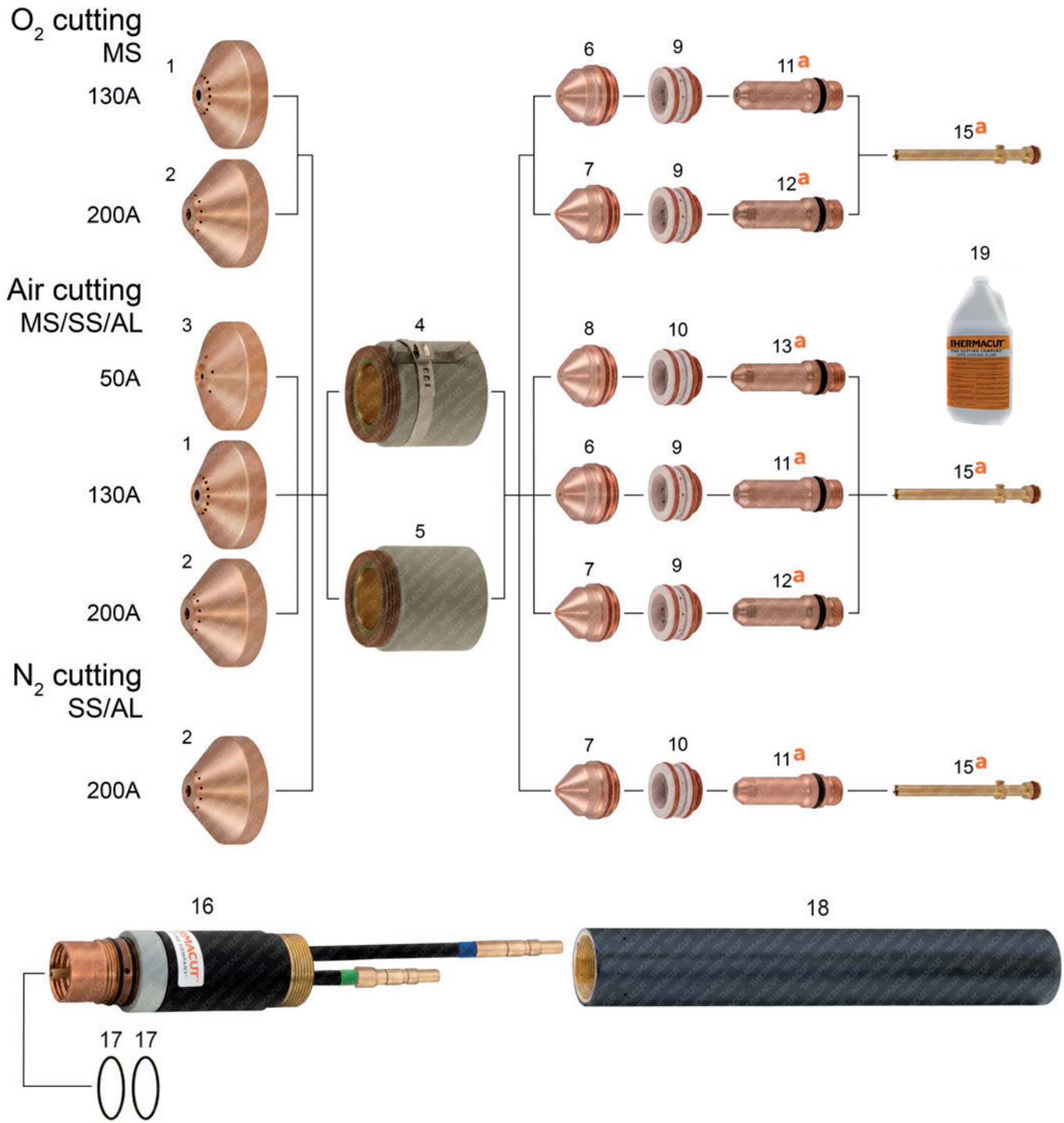

Parts for HyPro™ / MaxPro™ line of Max200® also available; see other pages for details

THERMACUT®, FHT-EX® AND EX-TRAFIRE® ARE REGISTERED TRADEMARKS OF THERMACUT, K. S. AND MAY BE REGISTERED IN CZECH REPUBLIC AND/OR OTHER COUNTRIES. ALL OTHER TRADEMARKS ARE PROPERTIES OF THEIR RESPECTIVE OWNERS. THERMACUT IS NO WAY AFFILIATED WITH HYPERTHERM®. MOST THERMACUT PARTS ARE MADE FOR OR BY AN IBG COMPANY. PARTS INDICATED WITH A OEM ARE ORIGINAL PARTS MANUFACTURED BY THE ABOVE NAMED MANUFACTURER AND ARE BEING RESOLD BY THERMACUT. THERMACUT RESERVES THE RIGHT TO SUBSTITUTE OEM PARTS IN PLACE OF THERMACUT PARTS. VALID FROM SEPTEMBER 2024 • PREVIOUS VERSION IS NO LONGER VALID. • © COPYRIGHT 2024 BY THERMACUT® CZECH REPUBLIC. ALL RIGHTS RESERVED.

**THERMACUT® REPLACEMENT PARTS SUITABLE FOR
Hypertherm®
MaxPro™200 UPGRADE TORCH
FOR MAX®200 MILD STEEL, STAINLESS STEEL, ALUMINIUM**



PRODUCT BROCHURE WITH DETAILS AT
WWW.THERMACUT.COM

Item	Part No.	Ref. No.	Description	Std. Pkg.	Item	Part No.	Ref. No.	Description	Std. Pkg.
1.	T-11284	220536	Shield 130A, O ₂ /Air	1	a 11.	T-11304	220487-UR	Electrode 130A, O ₂ /Air	5
2.	T-11376	420045	Shield 200A, Air/N ₂	1	a 12.	T-11317	220937-UR	Electrode 200A, O ₂ /Air	5
3.	T-11283	220532	Shield 50A, Air	1	a 13.	T-11309	220528-UR	Electrode 45A (50A)	5
4.	T-13097	220936	Retaining Cap 50-200A, O ₂ /Air (200A, N ₂), HD	1	a 14.	T-0382	020415-UR	Electrode 100-200A	5
5.	T-13096	220935	Retaining Cap 50-200A, O ₂ /Air (200A, N ₂), w/o IHS, HD	1	a 15.	T-11307	220521-UR	Cooling Tube (use with TMT electrode)	1
6.	T-11315*	220892-UR	Nozzle 130A, O ₂ /Air	5	16.	T-13154	420087-UR	Torch Body MaxPro™200	1
7.	T-11837*	420044-UR	Nozzle 200A, O ₂ /Air/N ₂	5	17.	N-10094	1-027B	O-Ring	1
8.	T-11313*	220890-UR	Nozzle 50A, Air	5	18.	T-13160	220943	Mounting Sleeve 2"	1
9.	T-11280	220488	Swirl Ring 130A (200A)	1	19.	Coolant Liquid. Details on the Accessories page.			
10.	T-11282	220529	Swirl Ring 50A, Air (200A, N ₂)	1	Parts HyPro™/MaxPro™ for line HT®2000 available also, see other pages for details.				

* FULLY INTERCHANGEABLE WITH ORIGINAL PARTS, BUT DIFFERS FROM ORIGINAL DESIGN

a THERMACUT® ELECTRODES HAS TO BE USED WITH THERMACUT® DESIGN COOLING TUBE, OTHERWISE IT DOESN'T FIT TO THE TORCH, THERMACUT® COOLING TUBE CAN BE USED FOR THERMACUT® DESIGN ELECTRODES AND FOR ORIGINAL DESIGN TOO.

NS NOT SHOWN IN THE PICTURE

W/O WITHOUT

HD HEAVY DUTY - OFFERS HIGHER THERMAL RESISTANCE OF THREAD AREA, WHICH COULD BE DAMAGED DURING PIERCING.

THERMACUT®, FHT-EX® AND EX-TRAFIRE® ARE REGISTERED TRADEMARKS OF THERMACUT, K. S. AND MAY BE REGISTERED IN CZECH REPUBLIC AND/OR OTHER COUNTRIES. ALL OTHER TRADEMARKS ARE PROPERTIES OF THEIR RESPECTIVE OWNERS. THERMACUT IS NO WAY AFFILIATED WITH HYPERTHERM®. MOST THERMACUT PARTS ARE MADE FOR OR BY AN IBG COMPANY. PARTS INDICATED WITH A OEM ARE ORIGINAL PARTS MANUFACTURED BY THE ABOVE NAMED MANUFACTURER AND ARE BEING RESOLD BY THERMACUT. THERMACUT RESERVES THE RIGHT TO SUBSTITUTE OEM PARTS IN PLACE OF THERMACUT PARTS.
VALID FROM SEPTEMBER 2024 • PREVIOUS VERSION IS NO LONGER VALID. • © COPYRIGHT 2024 BY THERMACUT® CZECH REPUBLIC. ALL RIGHTS RESERVED.

**THERMACUT® REPLACEMENT PARTS SUITABLE FOR
Hypertherm®
HT® 400, HT® 4000, HT® 4001**

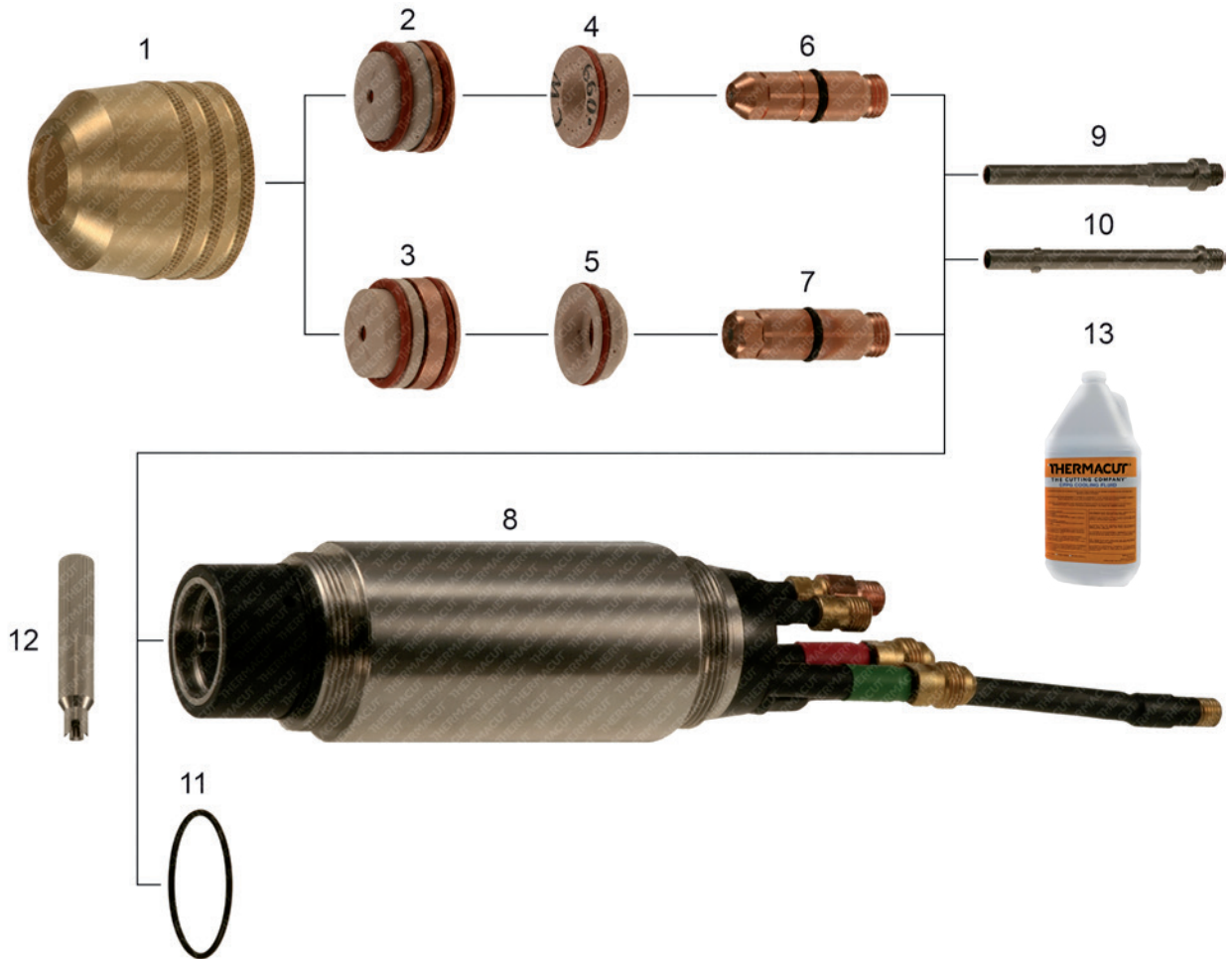

THERMACUT®, FHT-EX® AND EX-TRAFIRE® ARE REGISTERED TRADEMARKS OF THERMACUT, K. S. AND MAY BE REGISTERED IN CZECH REPUBLIC AND/OR OTHER COUNTRIES. ALL OTHER TRADEMARKS ARE PROPERTIES OF THEIR RESPECTIVE OWNERS. THERMACUT IS NO WAY AFFILIATED WITH HYPERTHERM®. MOST THERMACUT PARTS ARE MADE FOR OR BY AN IBG COMPANY. PARTS INDICATED WITH A OEM ARE ORIGINAL PARTS MANUFACTURED BY THE ABOVE NAMED MANUFACTURER AND ARE BEING RESOLD BY THERMACUT. THERMACUT RESERVES THE RIGHT TO SUBSTITUTE OEM PARTS IN PLACE OF THERMACUT PARTS. VALID FROM SEPTEMBER 2024 • PREVIOUS VERSION IS NO LONGER VALID. • © COPYRIGHT 2024 BY THERMACUT® CZECH REPUBLIC. ALL RIGHTS RESERVED.

THERMACUT® REPLACEMENT PARTS SUITABLE FOR Hypertherm® HT® 400

Item	Part No.	Ref. No.	Description	Std. Pkg.	Item	Part No.	Ref. No.	Description	Std. Pkg.
1.	T-0088	020579	Retaining Cap	1	#9.	T-1389#	020990 OEM	Water Tube (for OEM Torch)	1
2.	T-0078	020086	Nozzle 260A, 340A, O ₂	1	**10.	T-1388**	020990-UR	Water Tube (for TMT Torch)	1
3.	T-0080	020084	Nozzle .166, N ₂	1	11.	T-1006	044028	O-Ring	1
4.	T-0081	020096	Swirl Ring, O ₂	1	12.	T-1397	T-1397	Wrench for TMT Water Tube	1
5.	T-0020	020039	Swirl Ring .120/.166/.187, N ₂	1	13.	Coolant Liquid. Details on the Accessories page.			
6.	T-0083	020081	Electrode, O ₂	5					
7.	T-0084	020082	Electrode, N ₂	5					
8.	T-0085	020080	Torch Body HT®400	1					

HT® 4000

Item	Part No.	Ref. No.	Description	Std. Pkg.	Item	Part No.	Ref. No.	Description	Std. Pkg.
1.	T-0088	020579	Retaining Cap	1	7.	T-0084	020082	Electrode, N ₂	5
2.	T-0078	020086	Nozzle 260A, 340A, O ₂	1	8.	T-1393	020328	Torch Body HT®400	1
3.	T-0080	020084	Nozzle .166, N ₂	1	#9.	T-1389#	020990 OEM	Water Tube (for OEM Torch)	1
	T-0510	020282	Nozzle .166, N ₂	1	**10.	T-1388**	020990-UR	Water Tube (for TMT Torch)	1
	T-0511	020283	Nozzle .187, N ₂	1	11.	T-1006	044028	O-Ring	1
4.	T-1292	020623	Swirl Ring	1	12.	T-1397	T-1397	Wrench for TMT Water Tube	1
6.	T-1293	020663	Electrode, O ₂	5	13.	Coolant Liquid. Details on the Accessories page.			
	T-0083	020081	Electrode, O ₂	5					

HT® 4001

Item	Part No.	Ref. No.	Description	Std. Pkg.	Item	Part No.	Ref. No.	Description	Std. Pkg.
1.	T-0088	020579	Retaining Cap	1	7.	T-0084	020082	Electrode, N ₂	5
2.	T-0078	020086	Nozzle 260A, 340A, O ₂	1	8.	T-1393	020328	Torch Body HT®400	1
3.	T-0080	020084	Nozzle .166, N ₂	1	#9.	T-1389#	020990 OEM	Water Tube (for OEM Torch)	1
	T-0510	020282	Nozzle .166, N ₂	1	**10.	T-1388**	020990-UR	Water Tube (for TMT Torch)	1
	T-0511	020283	Nozzle .187, N ₂	1	11.	T-1006	044028	O-Ring	1
4.	T-1292	020623	Swirl Ring	1	12.	T-1397	T-1397	Wrench for TMT Water Tube	1
6.	T-1293	020663	Electrode, O ₂	5	13.	Coolant Liquid. Details on the Accessories page.			
	T-2846*	120630-UR	Electrode, O ₂	5					

ACCESSORIES

Item	Part No.	Ref. No.	Description	Std. Pkg.	Item	Part No.	Ref. No.	Description	Std. Pkg.
NS	T-0631	028137	Leads, Shielded, 10'	1	NS	T-0635	028141	Leads, Shielded, 30'	1
NS	T-0632	028138	Leads, Shielded, 15'	1	NS	T-0636	028142	Leads, Shielded, 35'	1
NS	T-0633	028139	Leads, Shielded, 20'	1	NS	T-0637	028143	Leads, Shielded, 40'	1
NS	T-0634	028140	Leads, Shielded, 25'	1	Individual cable hoses available upon request				

COMPATIBLE WITH OEM TORCH ONLY, DOESN'T FIT TO THERMACUT® TORCH.

** COMPATIBLE WITH THERMACUT® AND OEM TORCH

NS NOT SHOWN IN THE PICTURE

THERMACUT®, FHT-EX® AND EX-TRAFIRE® ARE REGISTERED TRADEMARKS OF THERMACUT, K. S. AND MAY BE REGISTERED IN CZECH REPUBLIC AND/OR OTHER COUNTRIES. ALL OTHER TRADEMARKS ARE PROPERTIES OF THEIR RESPECTIVE OWNERS. THERMACUT IS NO WAY AFFILIATED WITH HYPERTHERM®. MOST THERMACUT PARTS ARE MADE FOR OR BY AN IBG COMPANY. PARTS INDICATED WITH A OEM ARE ORIGINAL PARTS MANUFACTURED BY THE ABOVE NAMED MANUFACTURER AND ARE BEING RESOLD BY THERMACUT. THERMACUT RESERVES THE RIGHT TO SUBSTITUTE OEM PARTS IN PLACE OF THERMACUT PARTS.
VALID FROM SEPTEMBER 2024 • PREVIOUS VERSION IS NO LONGER VALID. • © COPYRIGHT 2024 BY THERMACUT® CZECH REPUBLIC. ALL RIGHTS RESERVED.

THERMACUT® REPLACEMENT PARTS SUITABLE FOR
Hypertherm®
PAC®500 | MODEL 500®

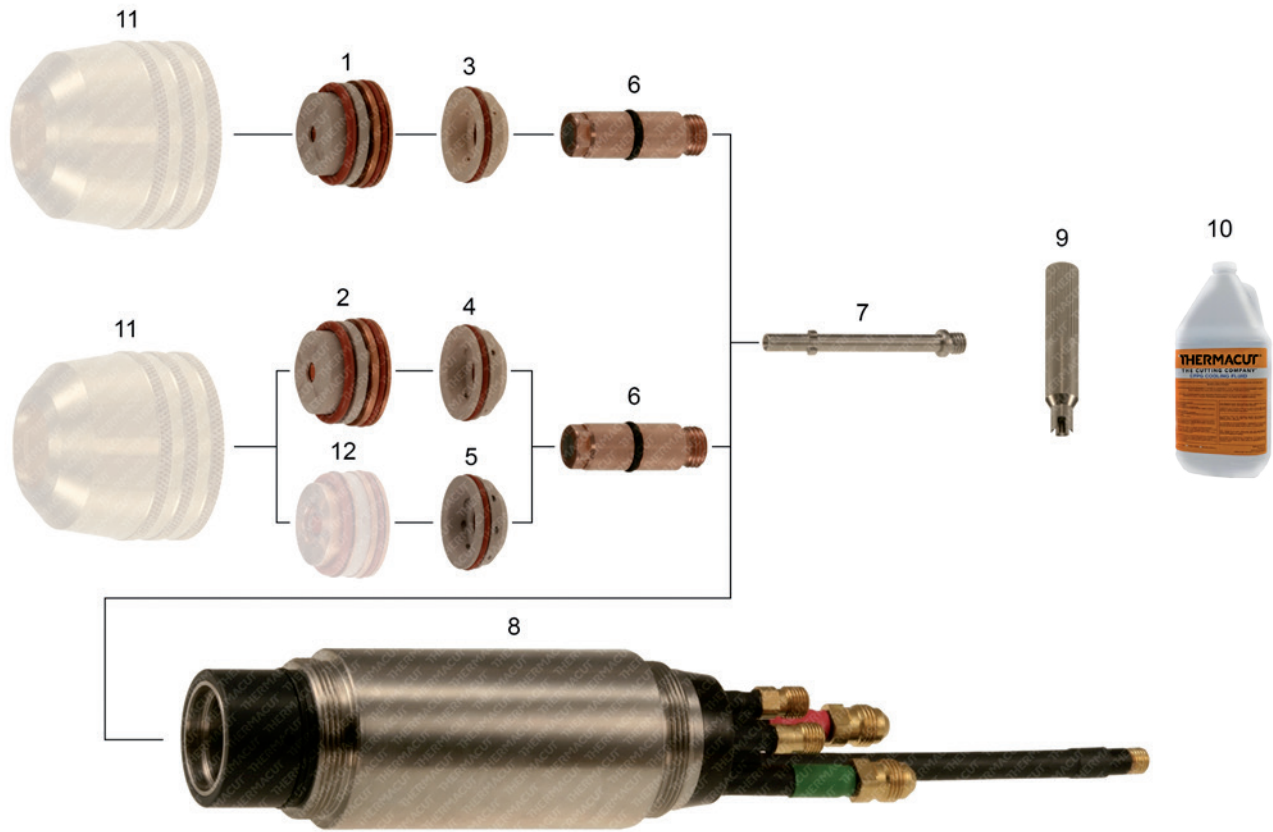

Item	Part No.	Ref. No.	Description	Std. Pkg	Item	Part No.	Ref. No.	Description	Std. Pkg
1.	T-0017	020036	Nozzle .187	1	NS	KT-1157	028141	HT®400, PAC®500 Cable Leads 9.2m (30')	1
2.	T-0018	020037	Nozzle .220	1	NS	KT-1153	028142	HT®400, PAC®500 Cable Leads 10.7m (35')	1
3.	T-0020	020039	Swirl Ring .120/.166/.187, N ₂	1	NS	KT-1404	028143	HT®400, PAC®500 Cable Leads 12.2m (40')	1
4.	T-0021	020042	Swirl Ring .166, .187, CCW	1	NS	KT-1217	K.HT400.15,2M.K	HT®400, PAC®500 Cable Leads 15.2m (50')	1
5.	T-0022	020040	Swirl Ring .220	1	NS	KT-1471	K.PAC500.6,1M	PAC®500 Mach. Torch with Leads 6.1m (20')	
	T-0023	020048	Swirl Ring .250	1	NS	KT-1165	K.PAC500.15,2M	PAC®500 Mach. Torch with Leads 15.2m (50')	1
6.	T-0024	020038	Electrode	5	NS	KT-1164	K.PAC500.22,9M	PAC®500 Mach. Torch with Leads 22.9m (75')	1
7.	T-1395	120035-UR	Water Tube, TMT Torch	1	10.			Coolant Liquid. Details on the Accessories page.	
8.	T-0025	020030	Torch Main Body PAC®500	1	11.-12.			Not available any more – OEM only.	
9.	T-1397	T-1397	Wrench for TMT Water Tube	1				Different types of cable leads available on request	
NS	KT-1214	028139	HT®400, PAC®500 Cable Leads 6.1m (20')	1					
NS	KT-1154	028140	HT®400, PAC®500 Cable Leads 7.6m (25')	1					

COMPATIBLE WITH OEM TORCH ONLY, DOESN'T FIT TO THERMACUT® TORCH

** COMPATIBLE WITH THERMACUT® AND OEM TORCH

NS NOT SHOWN IN THE PICTURE

THERMACUT®, FHT-EX® AND EX-TRAFIRE® ARE REGISTERED TRADEMARKS OF THERMACUT, K. S. AND MAY BE REGISTERED IN CZECH REPUBLIC AND/OR OTHER COUNTRIES. ALL OTHER TRADEMARKS ARE PROPERTIES OF THEIR RESPECTIVE OWNERS. THERMACUT IS NO WAY AFFILIATED WITH HYPERTHERM®. MOST THERMACUT PARTS ARE MADE FOR OR BY AN IBG COMPANY. PARTS INDICATED WITH A OEM ARE ORIGINAL PARTS MANUFACTURED BY THE ABOVE NAMED MANUFACTURER AND ARE BEING RESOLD BY THERMACUT. THERMACUT RESERVES THE RIGHT TO SUBSTITUTE OEM PARTS IN PLACE OF THERMACUT PARTS. VALID FROM SEPTEMBER 2024 • PREVIOUS VERSION IS NO LONGER VALID. • © COPYRIGHT 2024 BY THERMACUT® CZECH REPUBLIC. ALL RIGHTS RESERVED.

THERMACUT® REPLACEMENT PARTS SUITABLE FOR
Hypertherm®
HD®1070/HD®3070 HyDefinition® | PAC®182/PAC®186/PAC®190

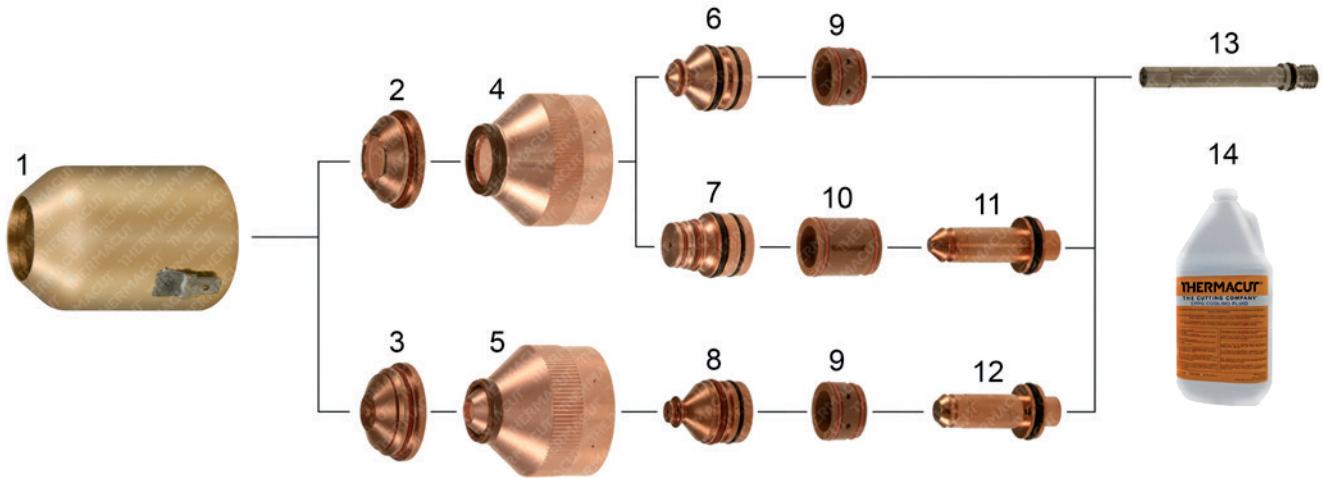

Item	Part No.	Ref. No.	Description	Std. Pkg.	Item	Part No.	Ref. No.	Description	Std. Pkg.
1.	T-2828	020687	Shield Cap, with IHS Tab	1	9.	T-8057	020637	Swirl Ring 15-100A MS	1
2.	T-8047	020796	Shield 70A MS/SS	10	10.	T-8058	020789	Swirl Ring 70A MS/SS	2
3.	T-8048	120273	Shield 100A MS	10	11.	T-8061	120112	Electrode 70A MS/SS	5
4.	T-8050	020795	Inner Retaining Cap 50-70A MS, SS	1	12.	T-8062	120410	Electrode 100A MS	5
5.	T-8051	120266	Inner Retaining Cap 100A MS	1	13.	T-8100	120377	Tube, Water Electrode Cooling, PAC®186	1
6.	T-8054	020646	Nozzle 50A MS	5	14.	Coolant Liquid. Details on the Accessories page.			
7.	T-8055	020647	Nozzle 70A MS, SS	5					
8.	T-8056	120272	Nozzle 100A MS	5					

MS MILD STEEL
SS STAINLESS STEEL

THERMACUT®, FHT-EX® AND EX-TRAFIRE® ARE REGISTERED TRADEMARKS OF THERMACUT, K. S. AND MAY BE REGISTERED IN CZECH REPUBLIC AND/OR OTHER COUNTRIES. ALL OTHER TRADEMARKS ARE PROPERTIES OF THEIR RESPECTIVE OWNERS. THERMACUT IS NO WAY AFFILIATED WITH HYPERTHERM®. MOST THERMACUT PARTS ARE MADE FOR OR BY AN IBG COMPANY. PARTS INDICATED WITH A OEM ARE ORIGINAL PARTS MANUFACTURED BY THE ABOVE NAMED MANUFACTURER AND ARE BEING RESOLD BY THERMACUT. THERMACUT RESERVES THE RIGHT TO SUBSTITUTE OEM PARTS IN PLACE OF THERMACUT PARTS.
 VALID FROM SEPTEMBER 2024 • PREVIOUS VERSION IS NO LONGER VALID. • © COPYRIGHT 2024 BY THERMACUT® CZECH REPUBLIC. ALL RIGHTS RESERVED.

THERMACUT® REPLACEMENT PARTS SUITABLE FOR
Hypertherm®
HyPerformance® Plasma | HPR®130/HPR®260 MILD STEEL

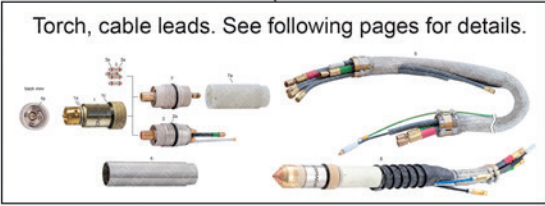
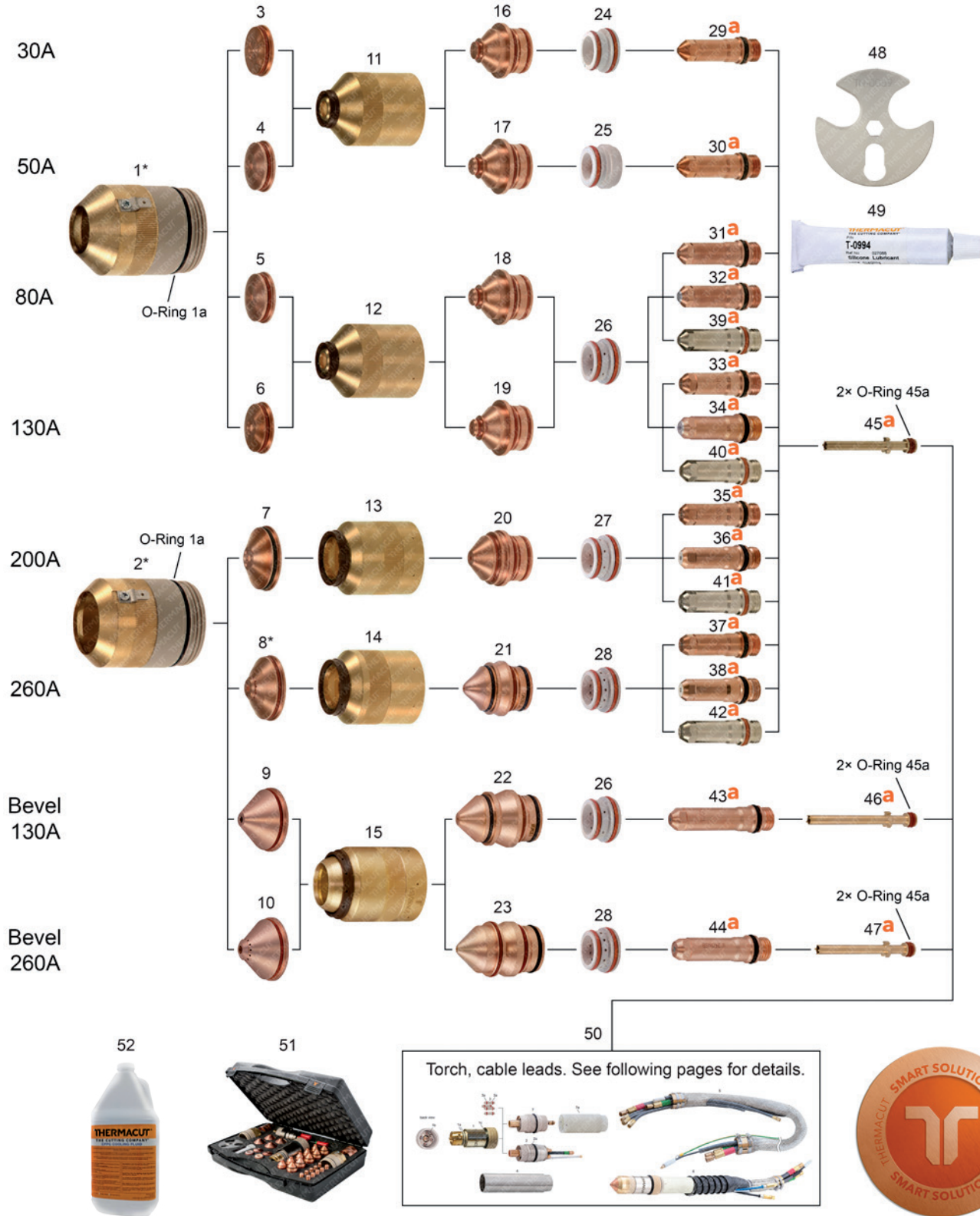

THERMACUT®, FHT-EX® AND EX-TRAFIRE® ARE REGISTERED TRADEMARKS OF THERMACUT, K. S. AND MAY BE REGISTERED IN CZECH REPUBLIC AND/OR OTHER COUNTRIES. ALL OTHER TRADEMARKS ARE PROPERTIES OF THEIR RESPECTIVE OWNERS. THERMACUT IS NO WAY AFFILIATED WITH HYPERTHERM®. MOST THERMACUT PARTS ARE MADE FOR OR BY AN IBG COMPANY. PARTS INDICATED WITH A OEM ARE ORIGINAL PARTS MANUFACTURED BY THE ABOVE NAMED MANUFACTURER AND ARE BEING RESOLD BY THERMACUT. THERMACUT RESERVES THE RIGHT TO SUBSTITUTE OEM PARTS IN PLACE OF THERMACUT PARTS. VALID FROM SEPTEMBER 2024 • PREVIOUS VERSION IS NO LONGER VALID. • © COPYRIGHT 2024 BY THERMACUT® CZECH REPUBLIC. ALL RIGHTS RESERVED.

THERMACUT® REPLACEMENT PARTS SUITABLE FOR
Hypertherm®
HyPerformance® Plasma | HPR®130/HPR®260 MILD STEEL



PRODUCT BROCHURE WITH DETAILS AT
WWW.THERMACUT.COM

Item	Part No.	Ref. No.	Description	Std. Pkg.	Item	Part No.	Ref. No.	Description	Std. Pkg.
1.	T-9961	220173-UR	Shield Cap 30-130A	1		T-10939	220542	Nozzle 260A, Bevel	1
1a.	N-10099	1-031B	O-Ring	1	24.	T-10297	220180	Swirl Ring 30-60A	1
2.	T-9964	220398-UR	Shield Cap 200/260A (130/260A, Bevel)	1	25.	T-10305	220553	Swirl Ring 50A	1
3.	T-10878	220194	Shield 30A	10	26.	T-10295	220179	Swirl Ring 80/130 (130A, Bevel)	1
4.	T-10882	220555	Shield 50A	10	27.	T-10296	220353	Swirl Ring 200A	1
5.	T-9838	220189	Shield 80A	10	28.	T-10271	220436	Swirl Ring 260A (260A, Bevel)	1
6.	T-9839	220183	Shield 130A	10	29.	T-9894	220192-UR	Electrode 30A	5
7.	T-9965	220356	Shield 200A	1	a 30.	T-10306	220552-UR	Electrode 50A	5
8.	T-9970	220440-UR	Shield 260A	1	a 31.	T-9895	220187-UR	Electrode 80A	5
9.	T-10311	220645	Shield 130A, Bevel	1	a 32.	T-12064	220187-PRO	Electrode 80A (=420566), Silver PRO	5
10.	T-10881	220545	Shield 260A, Bevel	1	a 33.	T-9920	220181-UR	Electrode 130A	5
11.	T-11146	220313	Inner Retaining Cap 30/50A	1	a 34.	T-11203	220181-PRO	Electrode 130A (=220665-PRO), Silver PRO	5
12.	T-11144	220176	Inner Retaining Cap 80/130A	1	a 35.	T-9969	220352-UR	Electrode 200A	5
13.	T-11149	220355	Inner Retaining Cap 200A	1	a 36.	T-11200	220352-PRO	Electrode 200A (=220666-PRO), Silver PRO	5
14.	T-11150	220433	Inner Retaining Cap 260A	1	a 37.	T-9974	220435-UR	Electrode 260A	5
15.	T-11151	220603	Inner Retaining Cap 130A/260A, Bevel	1	a 38.	T-11197	220435-PRO	Electrode 260A (=220668-PRO), Silver PRO	5
16.	T-9834	220193-UR	Nozzle 30A	1	a 39.	T-4927	220187-AG	Electrode 80A, SilverEX-®	5
	T-10936	220193	Nozzle 30A	1	a 40.	T-4917	220181-AG	Electrode 130A, SilverEX-®	5
17.	T-10313	220554-UR	Nozzle 50A	1	a 41.	T-4925	220352-AG	Electrode 200A, SilverEX-®	5
	T-10940	220554	Nozzle 50A	1	a 42.	T-4926	220435-AG	Electrode 260A, SilverEX-®	5
18.	T-9835	220188-UR	Nozzle 80A	1	a 43.	T-10309	220649-UR	Electrode 130A, Bevel	5
	T-10935	220188	Nozzle 80A	1	a 44.	T-10307	220541-UR	Electrode 260A, Bevel	5
19.	T-9836	220182-UR	Nozzle 130A	1	a 45.	T-9882	220340-UR	Cooling Tube 30-260A	1
	T-10934	220182	Nozzle 130A	1	45a.	T-13016	026009	O-Ring	1
NS	T-10248	220510-UR	Nozzle 100A, HD®3070 upgrade	1	a 46.	T-10472	220700-UR	Cooling Tube 80-200A, Bevel	1
NS	T-11265	220510	Nozzle 100A, HD®3070 upgrade	1	a 47.	T-10323	220571-UR	Cooling Tube 400A (260-400A, Bevel)	1
20.	T-9967	220354-UR	Nozzle 200A	1	*48.	TN-0069*	104119-UR	Consumables Removal Tool	1
	T-10937	220354	Nozzle 200A	1	49.	T-0994	027055	Silicone Lubricant 25ml	1
21.	T-9972	220439-UR	Nozzle 260A	1	50.	Torch, cable leads. See following pages for details.			
	T-10938	220439	Nozzle 260A	1	51.	Consumable Case. Details on the Accessories page.			
22.	T-10941	220646	Nozzle 130A, Bevel	1	52.	Coolant Liquid. Details on the Accessories page.			
23.	T-10308	220542-UR	Nozzle 260A, Bevel	1					

* FULLY INTERCHANGEABLE WITH ORIGINAL PARTS, BUT DIFFERS FROM ORIGINAL DESIGN

a THERMACUT® ELECTRODES HAS TO BE USED WITH THERMACUT® DESIGN COOLING TUBE, OTHERWISE IT DOESN'T FIT TO THE TORCH, THERMACUT® COOLING TUBE CAN BE USED FOR THERMACUT® DESIGN ELECTRODES AND FOR ORIGINAL DESIGN TOO

** SHIELD OFFERS BETTER LIFETIME BECAUSE OF IMPROVED DESIGN AND IS FULLY INTERCHANGEABLE AND COMPATIBLE WITH ORIGINAL PARTS

NS NOT SHOWN IN THE PICTURE

-PRO SILVER PRO TECHNOLOGY INCREASES ELECTRODE LIFETIME SIGNIFICANTLY COMPARED TO STANDARD COPPER ELECTRODES

SMART SOLUTION - DESIGN IMPROVEMENTS THAT BRINGS ADDED VALUE SUCH AS IMPROVED LIFETIME OF CONSUMABLES, EXCELLENT CUT QUALITY, SPEED OR BETTER COST EFFECTIVENESS OF YOUR SYSTEM

THERMACUT®, FHT-EX® AND EX-TRAFIRE® ARE REGISTERED TRADEMARKS OF THERMACUT, K. S. AND MAY BE REGISTERED IN CZECH REPUBLIC AND/OR OTHER COUNTRIES. ALL OTHER TRADEMARKS ARE PROPERTIES OF THEIR RESPECTIVE OWNERS. THERMACUT IS NO WAY AFFILIATED WITH HYPERTHERM®. MOST THERMACUT PARTS ARE MADE FOR OR BY AN IBG COMPANY. PARTS INDICATED WITH A OEM ARE ORIGINAL PARTS MANUFACTURED BY THE ABOVE NAMED MANUFACTURER AND ARE BEING RESOLD BY THERMACUT. THERMACUT RESERVES THE RIGHT TO SUBSTITUTE OEM PARTS IN PLACE OF THERMACUT PARTS. VALID FROM SEPTEMBER 2024 • PREVIOUS VERSION IS NO LONGER VALID. • © COPYRIGHT 2024 BY THERMACUT® CZECH REPUBLIC. ALL RIGHTS RESERVED.

THERMACUT® REPLACEMENT PARTS SUITABLE FOR
Hypertherm®
HyPerformance® Plasma | HPR®130/HPR®260 STAINLESS STEEL

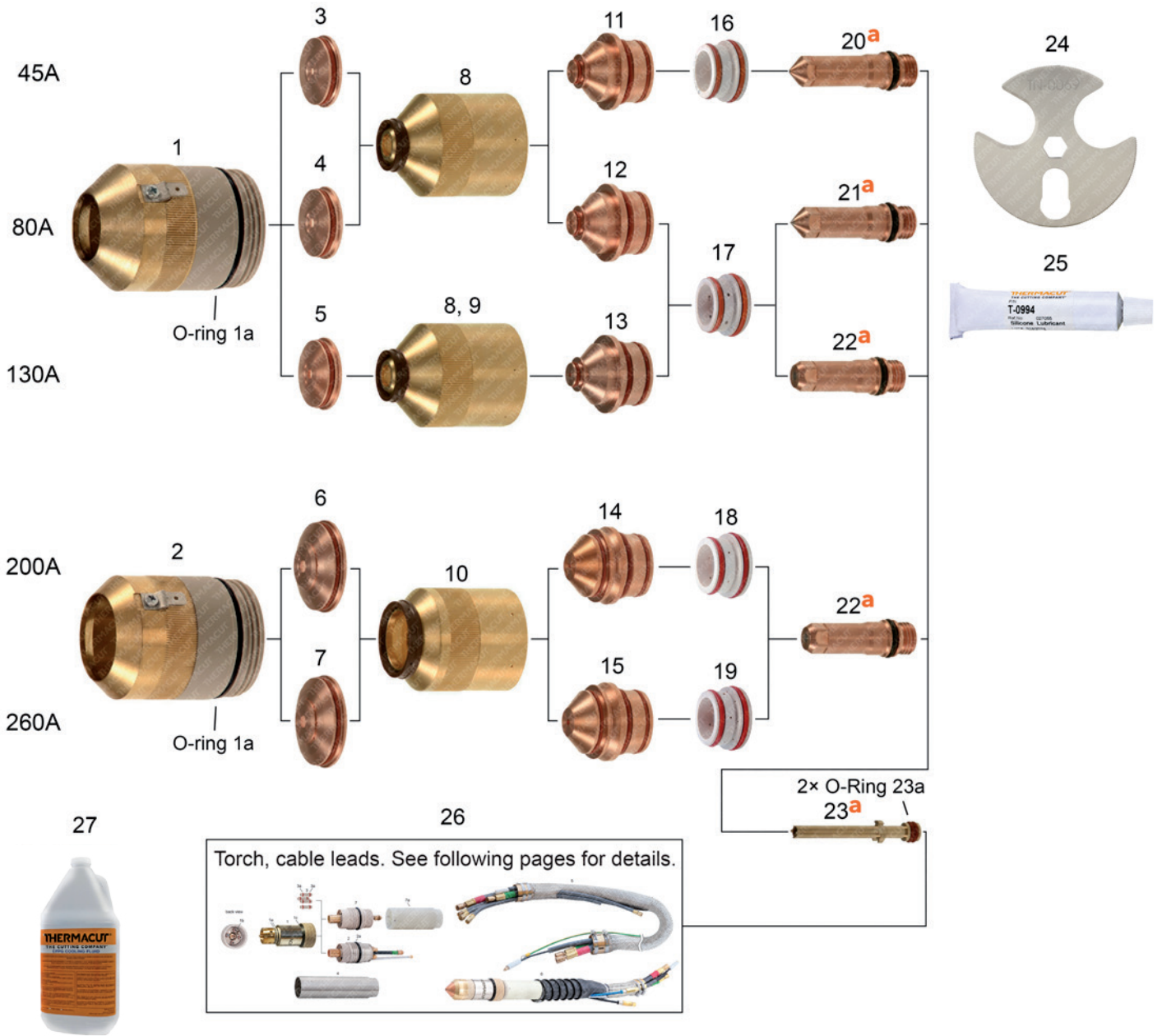

THERMACUT®, FHT-EX® AND EX-TRAFIRE® ARE REGISTERED TRADEMARKS OF THERMACUT, K. S. AND MAY BE REGISTERED IN CZECH REPUBLIC AND/OR OTHER COUNTRIES. ALL OTHER TRADEMARKS ARE PROPERTIES OF THEIR RESPECTIVE OWNERS. THERMACUT IS NO WAY AFFILIATED WITH HYPERTHERM®. MOST THERMACUT PARTS ARE MADE FOR OR BY AN IBG COMPANY. PARTS INDICATED WITH A OEM ARE ORIGINAL PARTS MANUFACTURED BY THE ABOVE NAMED MANUFACTURER AND ARE BEING RESOLD BY THERMACUT. THERMACUT RESERVES THE RIGHT TO SUBSTITUTE OEM PARTS IN PLACE OF THERMACUT PARTS. VALID FROM SEPTEMBER 2024 • PREVIOUS VERSION IS NO LONGER VALID. • © COPYRIGHT 2024 BY THERMACUT® CZECH REPUBLIC. ALL RIGHTS RESERVED.



THERMACUT® REPLACEMENT PARTS SUITABLE FOR
Hypertherm®
HyPerformance® Plasma | HPR®130/HPR®260 STAINLESS STEEL



PRODUCT BROCHURE WITH DETAILS AT
WWW.THERMACUT.COM

Item	Part No.	Ref. No.	Description	Std. Pkg.	Item	Part No.	Ref. No.	Description	Std. Pkg.
1.	T-9961	220173-UR	Shield Cap 45-130A	1	17.	T-10295	220179	Swirl Ring 80A/130A (130A, Bevel)	1
2.	T-9964	220398-UR	Shield Cap 200/260A (130/260A, Bevel)	1	18.	T-10579	220342	Swirl Ring 200A	1
3.	T-9975	220202	Shield 45A	10	19.	T-10596	220405	Swirl Ring 260A (260A, Bevel)	1
4.	T-9979	220338	Shield 80A	10	a 20.	T-9978	220308-UR	Electrode 45A	5
5.	T-9982	220198	Shield 130A	10	a 21.	T-9981	220339-UR	Electrode 80A	5
6.	T-10879	220345	Shield 200A	1	a 22.	T-9984	220307-UR	Electrode 130A/200A/260A	5
7.	T-10880	220407	Shield 260A	10	a 23.	T-9882	220340-UR	Cooling Tube 30-260A	1
8.	T-11145	220304	Inner Retaining Cap 45A/80A/130A	1	23a.	N-10055	1-009S	O-Ring	1
9.	T-11144	220176	Inner Retaining Cap 130A (N ₂)	1	*24.	TN-0069*	104119-UR	Consumables Removal Tool	1
10.	T-11147	220344	Inner Retaining Cap 200A/260A	1	1a.	N-10099	1-031B	O-Ring	1
11.	T-9977	220201	Nozzle 45A	1	25.	T-0994	027055	Silicone Lubricant 25ml	1
12.	T-9980	220337	Nozzle 80A	5	26.	Torch, cable leads. See following pages for details.			
13.	T-9983	220197	Nozzle 130A	5	27.	Coolant Liquid. Details on the Accessories page.			
14.	T-9987	220343	Nozzle 200A	1					
15.	T-9990	220406	Nozzle 260A	1					
16.	T-10297	220180	Swirl Ring 30-60A	1					

* FULLY INTERCHANGEABLE WITH ORIGINAL PARTS, BUT DIFFERS FROM ORIGINAL DESIGN

a THERMACUT® ELECTRODES HAS TO BE USED WITH THERMACUT® DESIGN COOLING TUBE, OTHERWISE IT DOESN'T FIT TO THE TORCH, THERMACUT® COOLING TUBE CAN BE USED FOR THERMACUT® DESIGN ELECTRODES AND FOR ORIGINAL DESIGN TOO

SMART SOLUTION - DESIGN IMPROVEMENTS THAT BRINGS ADDED VALUE SUCH AS IMPROVED LIFETIME OF CONSUMABLES, EXCELLENT CUT QUALITY, SPEED OR BETTER COST EFFECTIVENESS OF YOUR SYSTEM

THERMACUT®, FHT-EX® AND EX-TRAFIRE® ARE REGISTERED TRADEMARKS OF THERMACUT, K. S. AND MAY BE REGISTERED IN CZECH REPUBLIC AND/OR OTHER COUNTRIES. ALL OTHER TRADEMARKS ARE PROPERTIES OF THEIR RESPECTIVE OWNERS. THERMACUT IS NO WAY AFFILIATED WITH HYPERTHERM®. MOST THERMACUT PARTS ARE MADE FOR OR BY AN IBG COMPANY. PARTS INDICATED WITH A OEM ARE ORIGINAL PARTS MANUFACTURED BY THE ABOVE NAMED MANUFACTURER AND ARE BEING RESOLD BY THERMACUT. THERMACUT RESERVES THE RIGHT TO SUBSTITUTE OEM PARTS IN PLACE OF THERMACUT PARTS. VALID FROM SEPTEMBER 2024 • PREVIOUS VERSION IS NO LONGER VALID. • © COPYRIGHT 2024 BY THERMACUT® CZECH REPUBLIC. ALL RIGHTS RESERVED.

THERMACUT® REPLACEMENT PARTS SUITABLE FOR
Hypertherm®
HyPerformance® Plasma | HPR®130/HPR®260 ALUMINIUM

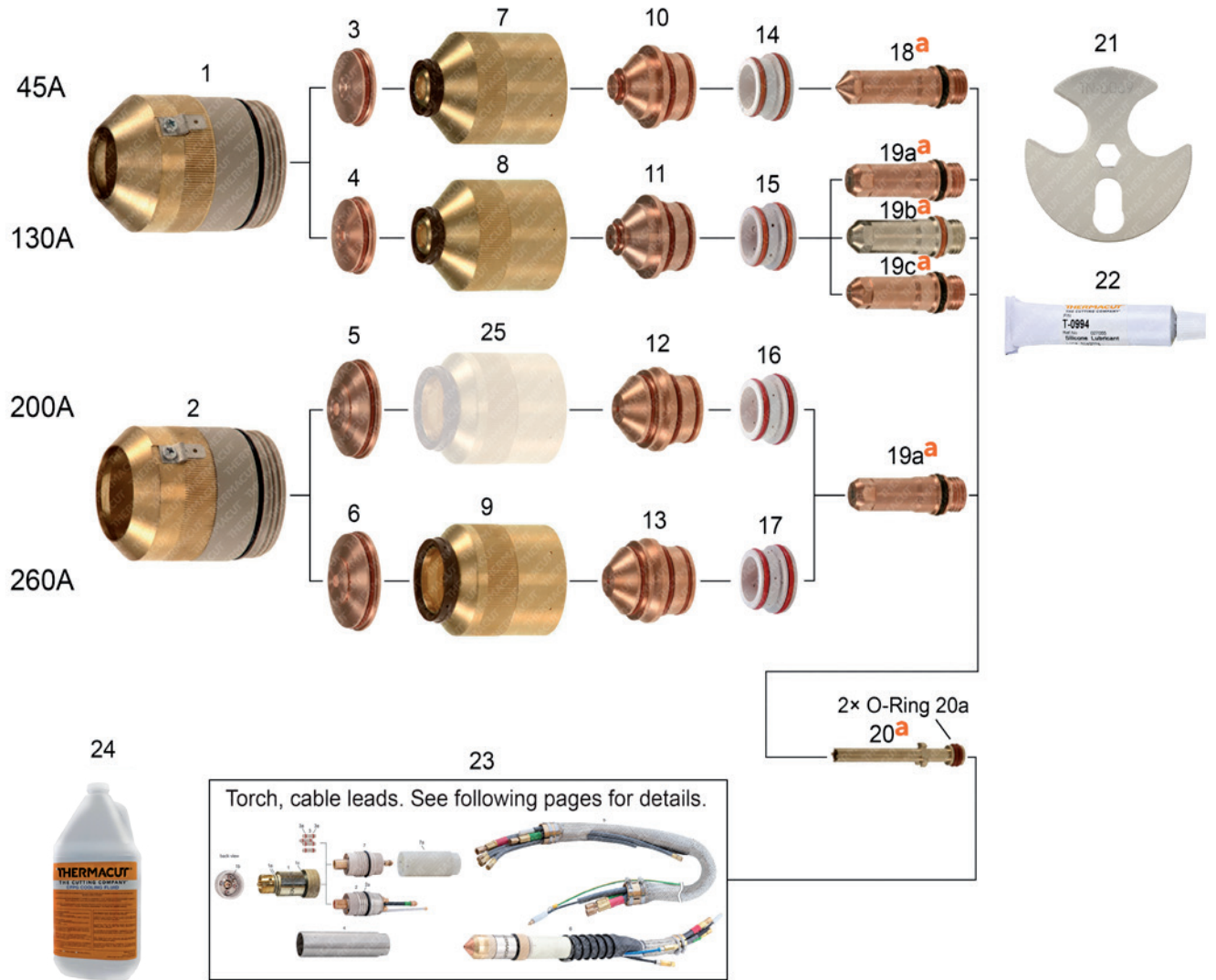

THERMACUT®, FHT-EX® AND EX-TRAFIRE® ARE REGISTERED TRADEMARKS OF THERMACUT, K. S. AND MAY BE REGISTERED IN CZECH REPUBLIC AND/OR OTHER COUNTRIES. ALL OTHER TRADEMARKS ARE PROPERTIES OF THEIR RESPECTIVE OWNERS. THERMACUT IS NO WAY AFFILIATED WITH HYPERTHERM®. MOST THERMACUT PARTS ARE MADE FOR OR BY AN IBG COMPANY. PARTS INDICATED WITH A OEM ARE ORIGINAL PARTS MANUFACTURED BY THE ABOVE NAMED MANUFACTURER AND ARE BEING RESOLD BY THERMACUT. THERMACUT RESERVES THE RIGHT TO SUBSTITUTE OEM PARTS IN PLACE OF THERMACUT PARTS. VALID FROM SEPTEMBER 2024 • PREVIOUS VERSION IS NO LONGER VALID. • © COPYRIGHT 2024 BY THERMACUT® CZECH REPUBLIC. ALL RIGHTS RESERVED.

THERMACUT® REPLACEMENT PARTS SUITABLE FOR
Hypertherm®
HyPerformance® Plasma | HPR®130/HPR®260 ALUMINIUM



PRODUCT BROCHURE WITH DETAILS AT
WWW.THERMACUT.COM

Item	Part No.	Ref. No.	Description	Std. Pkg.	Item	Part No.	Ref. No.	Description	Std. Pkg.
1.	T-9961	220173-UR	Shield Cap 45-130A	1	15.	T-10295	220179	Swirl Ring 130A	1
2.	T-9964	220398-UR	Shield Cap 200/260A	1	16.	T-10579	220342	Swirl Ring 200A	1
3.	T-9975	220202	Shield 45A	10	17.	T-10596	220405	Swirl Ring 260A	1
4.	T-9982	220198	Shield 130A	10	a 18.	T-9978	220308-UR	Electrode 45A	5
5.	T-10879	220345	Shield 200A	1	a 19c	T-9920	220181-UR	Electrode 130A	5
6.	T-10880	220407	Shield 260A	10	a 19b	T-4917	220181-AG	Electrode 130A, SilverEX-®	5
7.,8.	T-11144	220176	Inner Retaining Cap 45A/130A	1	a 19a	T-9984	220307-UR	Electrode 130A/200A/260A	5
8.	T-11145	220304	Inner Retaining Cap 130A	1	a 20.	T-9882	220340-UR	Cooling Tube 30-260A	1
9.	T-11147	220344	Inner Retaining Cap 260A	1	20a.	N-10055	1-009S	O-Ring	1
10.	T-9977	220201	Nozzle 45A	1	*21.	TN-0069*	104119-UR	Consumables Removal Tool	1
11.	T-9983	220197	Nozzle 130A	5	22.	T-0994	027055	Silicone Lubricant 25ml	1
12.	T-9993	220346	Nozzle 200A	1	23.	Torch, cable leads. See following pages for details.			
13.	T-9990	220406	Nozzle 260A	1	24.	Coolant Liquid. Details on the Accessories page.			
14.	T-10297	220180	Swirl Ring 45A	1	25.	Not available any more - OEM only.			

* FULLY INTERCHANGEABLE WITH ORIGINAL PARTS, BUT DIFFERS FROM ORIGINAL DESIGN

a THERMACUT® ELECTRODES HAS TO BE USED WITH THERMACUT® DESIGN COOLING TUBE, OTHERWISE IT DOESN'T FIT TO THE TORCH, THERMACUT® COOLING TUBE CAN BE USED FOR THERMACUT® DESIGN ELECTRODES AND FOR ORIGINAL DESIGN TOO

SMART SOLUTION - DESIGN IMPROVEMENTS THAT BRINGS ADDED VALUE SUCH AS IMPROVED LIFETIME OF CONSUMABLES, EXCELLENT CUT QUALITY, SPEED OR BETTER COST EFFECTIVENESS OF YOUR SYSTEM

THERMACUT®, FHT-EX® AND EX-TRAFIRE® ARE REGISTERED TRADEMARKS OF THERMACUT, K. S. AND MAY BE REGISTERED IN CZECH REPUBLIC AND/OR OTHER COUNTRIES. ALL OTHER TRADEMARKS ARE PROPERTIES OF THEIR RESPECTIVE OWNERS. THERMACUT IS NO WAY AFFILIATED WITH HYPERTHERM®. MOST THERMACUT PARTS ARE MADE FOR OR BY AN IBG COMPANY. PARTS INDICATED WITH A OEM ARE ORIGINAL PARTS MANUFACTURED BY THE ABOVE NAMED MANUFACTURER AND ARE BEING RESOLD BY THERMACUT. THERMACUT RESERVES THE RIGHT TO SUBSTITUTE OEM PARTS IN PLACE OF THERMACUT PARTS. VALID FROM SEPTEMBER 2024 • PREVIOUS VERSION IS NO LONGER VALID. • © COPYRIGHT 2024 BY THERMACUT® CZECH REPUBLIC. ALL RIGHTS RESERVED.

**THERMACUT® REPLACEMENT PARTS SUITABLE FOR
Hypertherm®
HPR®130/HPR®260 | TORCHES AND CABLE LEADS**

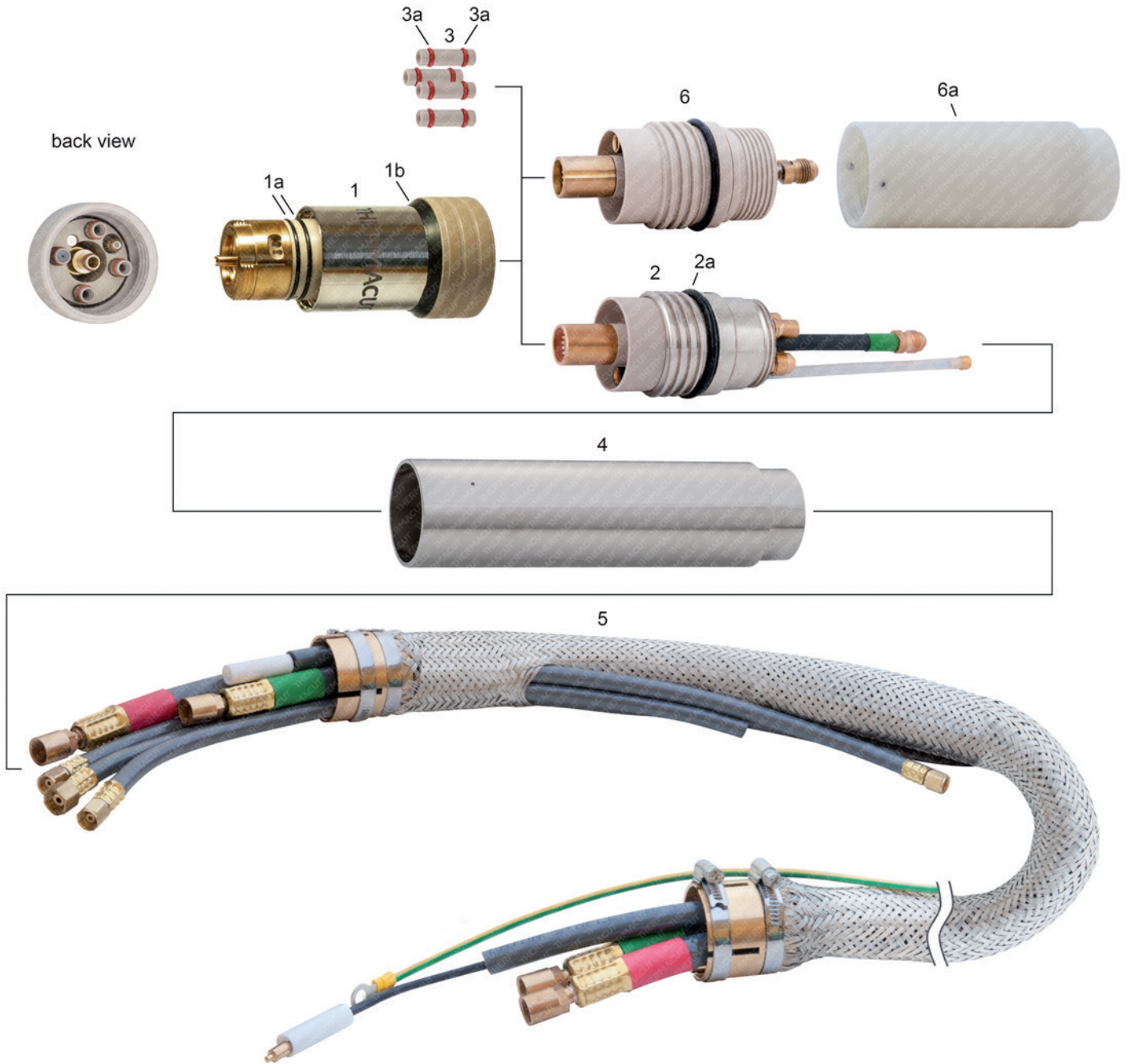

THERMACUT®, FHT-EX® AND EX-TRAFIRE® ARE REGISTERED TRADEMARKS OF THERMACUT, K. S. AND MAY BE REGISTERED IN CZECH REPUBLIC AND/OR OTHER COUNTRIES. ALL OTHER TRADEMARKS ARE PROPERTIES OF THEIR RESPECTIVE OWNERS. THERMACUT IS NO WAY AFFILIATED WITH HYPERTHERM®. MOST THERMACUT PARTS ARE MADE FOR OR BY AN IBG COMPANY. PARTS INDICATED WITH A OEM ARE ORIGINAL PARTS MANUFACTURED BY THE ABOVE NAMED MANUFACTURER AND ARE BEING RESOLD BY THERMACUT. THERMACUT RESERVES THE RIGHT TO SUBSTITUTE OEM PARTS IN PLACE OF THERMACUT PARTS. VALID FROM SEPTEMBER 2024 • PREVIOUS VERSION IS NO LONGER VALID. • © COPYRIGHT 2024 BY THERMACUT® CZECH REPUBLIC. ALL RIGHTS RESERVED.

**THERMACUT® REPLACEMENT PARTS SUITABLE FOR
Hypertherm®
HPR®130/HPR®260 | TORCHES AND CABLE LEADS**

Item	Part No.	Ref. No.	Description	Std. Pkg.	Item	Part No.	Ref. No.	Description	Std. Pkg.
1., 3.	T-11137	220162	Torch Q.D. Orig. design (incl. item 3 - 4 pcs.; included 2 pcs. Cooling Tube 220340-UR)	1		T-11616+	128784-UR+	Cable Leads 7.5m (25ft)	1
							128987-UR+	Cable Leads 10m (35ft)	1
1a.	N-10096	1-028B	O-Ring	1		T-11617+	128785-UR+	Cable Leads 15m (50ft)	1
1b.	N-18157		Conical Sealing	10			128988-UR+	Cable Leads 20m (65ft)	1
2.	T-11138	220163	Receptacle Q. D. Original design	1			228040-UR*	Cable Leads 4.5m (15ft)	1
2a.	N-18108	N-18108	O-Ring	1			228043-UR*	Cable Leads 7.5m (25ft)	1
3.	T-11769	T-11769	Connector Tube HPR® with O-Rings	1			228065-UR*	Cable Leads 10m (35ft)	1
3a.	N-10055	1-009S	O-Ring	1			228245-UR*	Cable Leads 15m (50ft)	1
4.	T-10492	220232	Mounting Tube	1			228066-UR*	Cable Leads 20m (65ft)	1
5.	T-11614+	128986-UR+	Cable Leads 2m (6ft)	1	##6.	T-11409##	220573	Receptacle Q. D., Bevel	1
	KT-1397+	128935-UR+	Cable Leads 3m (10ft)	1	##6a.	T-11410##	220546	Torch mounting sleeve, Bevel	1
	T-11615+	128934-UR+	Cable Leads 4.5m (15ft)	1					

MUST BE USED ONLY AS A SET OF ITEMS 3 AND 4, THIS COMPLETE SET IS INTERCHANGEABLE AND COMPATIBLE WITH ORIGINAL PARTS

RECEPTACLE Q. D., BEVEL POS. 6 IS NOT COMPATIBLE WITH STANDARD CABLE LEADS POS. 5

Q. D. QUICK DISCONNECT

NS NOT SHOWN IN THE PICTURE

ALL PARTS ARE WITH O-RINGS

THERMACUT®, FHT-EX® AND EX-TRAFIRE® ARE REGISTERED TRADEMARKS OF THERMACUT, K. S. AND MAY BE REGISTERED IN CZECH REPUBLIC AND/OR OTHER COUNTRIES. ALL OTHER TRADEMARKS ARE PROPERTIES OF THEIR RESPECTIVE OWNERS. THERMACUT IS NO WAY AFFILIATED WITH HYPERTHERM®. MOST THERMACUT PARTS ARE MADE FOR OR BY AN IBG COMPANY. PARTS INDICATED WITH A OEM ARE ORIGINAL PARTS MANUFACTURED BY THE ABOVE NAMED MANUFACTURER AND ARE BEING RESOLD BY THERMACUT. THERMACUT RESERVES THE RIGHT TO SUBSTITUTE OEM PARTS IN PLACE OF THERMACUT PARTS. VALID FROM SEPTEMBER 2024 • PREVIOUS VERSION IS NO LONGER VALID. • © COPYRIGHT 2024 BY THERMACUT® CZECH REPUBLIC. ALL RIGHTS RESERVED.

THERMACUT® REPLACEMENT PARTS SUITABLE FOR
Hypertherm®
HyPerformance® Plasma
HPR®130XD/HPR®260XD/HPR®400XD MILD STEEL

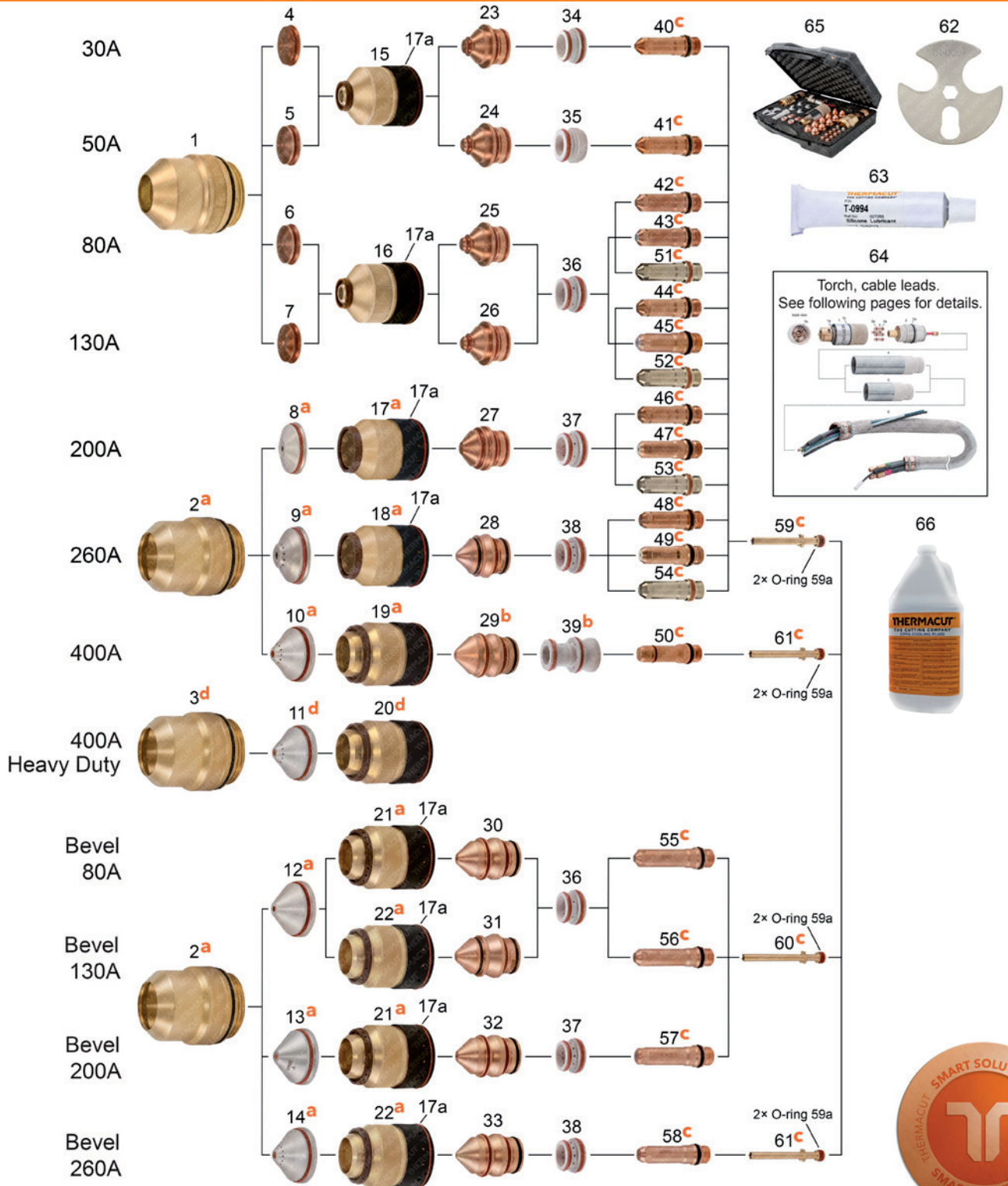

THERMACUT®, FHT-EX® AND EX-TRAFIRE® ARE REGISTERED TRADEMARKS OF THERMACUT, K. S. AND MAY BE REGISTERED IN CZECH REPUBLIC AND/OR OTHER COUNTRIES. ALL OTHER TRADEMARKS ARE PROPERTIES OF THEIR RESPECTIVE OWNERS. THERMACUT IS NO WAY AFFILIATED WITH HYPERTHERM®. MOST THERMACUT PARTS ARE MADE FOR OR BY AN IBC COMPANY. PARTS INDICATED WITH A OEM ARE ORIGINAL PARTS MANUFACTURED BY THE ABOVE NAMED MANUFACTURER AND ARE BEING RESOLD BY THERMACUT. THERMACUT RESERVES THE RIGHT TO SUBSTITUTE OEM PARTS IN PLACE OF THERMACUT PARTS. VALID FROM SEPTEMBER 2024 • PREVIOUS VERSION IS NO LONGER VALID. • © COPYRIGHT 2024 BY THERMACUT® CZECH REPUBLIC. ALL RIGHTS RESERVED.

THERMACUT® REPLACEMENT PARTS SUITABLE FOR
Hypertherm®
HyPerformance® Plasma
HPR®130XD/HPR®260XD/HPR®400XD MILD STEEL



PRODUCT BROCHURE WITH DETAILS AT
WWW.THERMACUT.COM
 VIDEO AVAILABLE AT YOUTUBE CHANNEL

Item	Part No.	Ref. No.	Description	Std. Pkg.	Item	Part No.	Ref. No.	Description	Std. Pkg.
	1. T-11271	220747	Shield Cap 30-130A	1	34. T-10297	220180	Swirl Ring 30-60A	1	
a	2. T-11270	220637-UR	Shield Cap 200-400A	1	35. T-10305	220553	Swirl Ring 50A	1	
d	3. T-13279	220637-HD	Shield Cap, HD 200-400A	1	36. T-10295	220179	Swirl Ring 80/130A (80/130A, Bevel)	1	
	4. T-10878	220194	Shield 30A	10	37. T-10296	220353	Swirl Ring 200A	1	
	5. T-10882	220555	Shield 50A	10	38. T-10271	220436	Swirl Ring 260A (260A, Bevel)	1	
	6. T-9838	220189	Shield 80A	10	NEW 39. T-12267	220631-UR	Swirl Ring 400A (400A, Bevel)	5	
	7. T-9839	220183	Shield 130A	10	C 40. T-9894	220192-UR	Electrode 30A	5	
a	8. T-11276	220761-UR	Shield 200A	1	C 41. T-10306	220552-UR	Electrode 50A	5	
a	9. T-11277	220764-UR	Shield 260A	1	C 42. T-9895	220187-UR	Electrode 80A	5	
NEW a	10. T-12272	220636-UR	Shield 400A	1	C 43. T-12064	220187-PRO	Electrode 80A (=420566), Silver PRO	5	
a	11. T-11403	220742-UR	Shield 80/130A, Bevel	1	C 44. T-9920	220181-UR	Electrode 130A	5	
a	12. T-11424	220658-UR	Shield 200A, Bevel	1	C 45. T-11203	220181-PRO	Electrode 130A (=220665-PRO), Silver PRO	5	
a	13. T-11402	220741-UR	Shield 260A, Bevel	1	C 46. T-9969	220352-UR	Electrode 200A	5	
d	14. T-13278	220636-HD	Shield, HD 200-400A	1	C 47. T-11200	220352-PRO	Electrode 200A (=220666-PRO), Silver PRO	5	
	15. T-11272	220754	Inner Retaining Cap 30/50A	1	C 48. T-9974	220435-UR	Electrode 260A	5	
	16. T-11273	220756	Inner Retaining Cap 80/130A	1	C 49. T-11197	220435-PRO	Electrode 260A (=220668-PRO), Silver PRO	5	
a	17. T-11274	220757-UR	Inner Retaining Cap 200A	1	NEW C 50. T-12269	220629-UR	Electrode 400A (400A, Bevel)	10	
	17a. N-20194		O-Ring	1	C 51. T-4927	220187-AG	Electrode 80A, SilverEX-®	5	
a	18. T-11275	220760-UR	Inner Retaining Cap 260A	1	C 52. T-4917	220181-AG	Electrode 130A, SilverEX-®	5	
NEW a	19. T-12271	220635-UR	Inner Retaining Cap 400A	1	C 53. T-4925	220352-AG	Electrode 200A, SilverEX-®	5	
a	20. T-11833	220845-UR	Inner Retaining Cap 80/200A, Bevel	1	C 54. T-4926	220435-AG	Electrode 260A, SilverEX-®	5	
a	21. T-11401	220740-UR	Inner Retaining Cap 130/260A, Bevel	1	C 55. T-11831	220802-UR	Electrode 80A, Bevel	5	
d	22. T-13277	220635-HD	Inner Retaining Cap, HD 200-400A	1	C 56. T-10309	220649-UR	Electrode 130A, Bevel	5	
	23. T-10936	220193	Nozzle 30A	1	C 57. T-11426	220662-UR	Electrode 200A, Bevel	5	
	24. T-10940	220554	Nozzle 50A	1	C 58. T-10307	220541-UR	Electrode 260A, Bevel	5	
	25. T-10935	220188	Nozzle 80A	1	C 59. T-9882	220340-UR	Cooling Tube 30-260A	1	
	26. T-10934	220182	Nozzle 130A	1	59a. T-13016	026009	O-Ring	1	
	27. T-10937	220354	Nozzle 200A	1	C 60. T-10472	220700-UR	Cooling Tube 80-200A, Bevel	1	
	28. T-220439-US		Nozzle 260A	1	C 61. T-10323	220571-UR	Cooling Tube 400A (260-400A, Bevel) (400-600A, SS, AL)	1	
NEW b	29. T-12270	220632-UR	Nozzle 400A (400A, Bevel)	1	*62. TN-0069*	104119-UR	Consumables Removal Tool	1	
	30. T-11832	220806	Nozzle 80A, Bevel	1	63. T-0994	027055	Silicone Lubricant 25ml	1	
	31. T-10941	220646	Nozzle 130A, Bevel	1	64. Torch, Cable Leads. See following pages for details.				
	32. T-11425	220659	Nozzle 200A, Bevel	1	65. Consumable Case. Details on the Accessories page.				
	33. T-10308	220542-UR	Nozzle 260A, Bevel	1	66. Coolant Liquid. Details on the Accessories page.				

* FULLY INTERCHANGEABLE AND COMPATIBLE WITH ORIGINAL PARTS, BUT DIFFERS FROM ORIGINAL DESIGN

a MUST BE USED ONLY AS A SET OF SHIELD, SHIELD CAP AND INNER RETAINING CAP, THIS COMPLETE SET IS INTERCHANGEABLE AND COMPATIBLE WITH ORIGINAL PARTS

b MUST BE USED ONLY AS A SET OF NOZZLE AND SWIRL RING, THIS COMPLETE SET IS INTERCHANGEABLE AND COMPATIBLE WITH ORIGINAL PARTS

c THERMACUT® ELECTRODES HAS TO BE USED WITH THERMACUT® DESIGN COOLING TUBE, OTHERWISE IT DOESN'T FIT TO THE TORCH, THERMACUT® COOLING TUBE

CAN BE USED FOR THERMACUT® DESIGN ELECTRODES AND FOR ORIGINAL DESIGN TOO

d HD PARTS MUST BE USED AS A SET OF SHIELD CUP, SHIELD AND RETAINING CUP.

OEM ORIGINAL PARTS

-PRO SILVER PRO TECHNOLOGY INCREASES ELECTRODE LIFETIME SIGNIFICANTLY COMPARED TO STANDARD COPPER ELECTRODES

HD HEAVY DUTY, THREE PARTS SET ALLOWS PIERCING UP TO 50MM!

SMART SOLUTION - DESIGN IMPROVEMENTS THAT BRINGS ADDED VALUE SUCH AS IMPROVED LIFETIME OF CONSUMABLES, EXCELLENT CUT QUALITY, SPEED OR BETTER COST EFFECTIVENESS OF YOUR SYSTEM

THERMACUT®, FHT-EX® AND EX-TRAFIRE® ARE REGISTERED TRADEMARKS OF THERMACUT, K. S. AND MAY BE REGISTERED IN CZECH REPUBLIC AND/OR OTHER COUNTRIES. ALL OTHER TRADEMARKS ARE PROPERTIES OF THEIR RESPECTIVE OWNERS. THERMACUT IS NO WAY AFFILIATED WITH HYPERTHERM®.

MOST THERMACUT PARTS ARE MADE FOR OR BY AN IBG COMPANY. PARTS INDICATED WITH A OEM ARE ORIGINAL PARTS MANUFACTURED BY THE ABOVE NAMED MANUFACTURER AND ARE BEING RESOLD BY THERMACUT. THERMACUT RESERVES THE RIGHT TO SUBSTITUTE OEM PARTS IN PLACE OF THERMACUT PARTS.

VALID FROM SEPTEMBER 2024 • PREVIOUS VERSION IS NO LONGER VALID. • © COPYRIGHT 2024 BY THERMACUT® CZECH REPUBLIC. ALL RIGHTS RESERVED.

THERMACUT® REPLACEMENT PARTS SUITABLE FOR
Hypertherm®
HyPerformance® Plasma
HPR®130XD/HPR®260XD/HPR®400XD STAINLESS STEEL

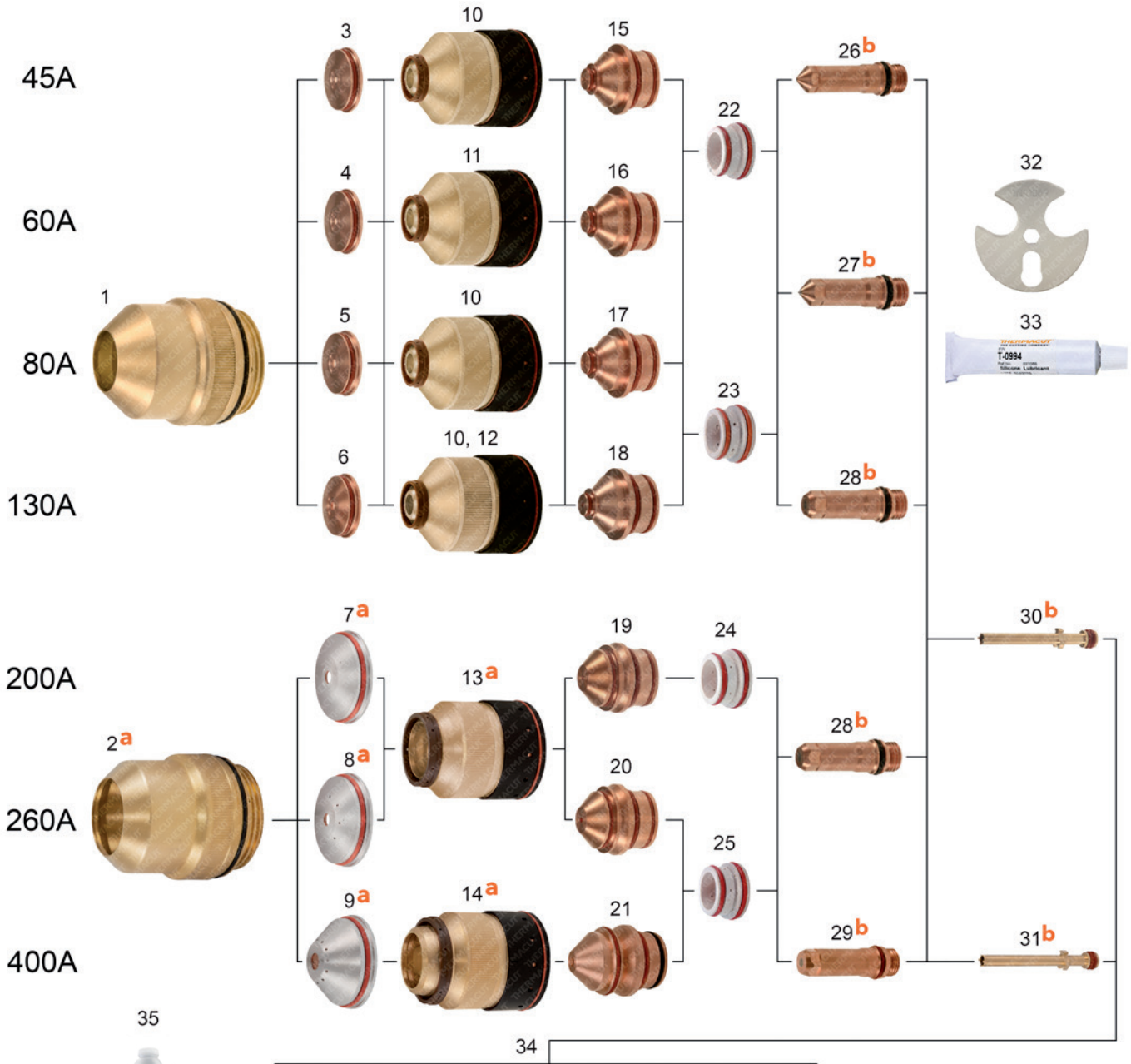

34

Torch, cable leads.
 See following pages for details.



THERMACUT®, FHT-EX® AND EX-TRAFIRE® ARE REGISTERED TRADEMARKS OF THERMACUT, K. S. AND MAY BE REGISTERED IN CZECH REPUBLIC AND/OR OTHER COUNTRIES. ALL OTHER TRADEMARKS ARE PROPERTIES OF THEIR RESPECTIVE OWNERS. THERMACUT IS NO WAY AFFILIATED WITH HYPERTHERM®. MOST THERMACUT PARTS ARE MADE FOR OR BY AN IBG COMPANY. PARTS INDICATED WITH A OEM ARE ORIGINAL PARTS MANUFACTURED BY THE ABOVE NAMED MANUFACTURER AND ARE BEING RESOLD BY THERMACUT. THERMACUT RESERVES THE RIGHT TO SUBSTITUTE OEM PARTS IN PLACE OF THERMACUT PARTS. VALID FROM SEPTEMBER 2024 • PREVIOUS VERSION IS NO LONGER VALID. • © COPYRIGHT 2024 BY THERMACUT® CZECH REPUBLIC. ALL RIGHTS RESERVED.

THERMACUT® REPLACEMENT PARTS SUITABLE FOR Hypertherm®

HyPerformance® Plasma

HPR® 130XD/HPR® 260XD/HPR® 400XD STAINLESS STEEL

PRODUCT BROCHURE WITH DETAILS AT
WWW.THERMACUT.COM
VIDEO AVAILABLE AT YOUTUBE CHANNEL



Item	Part No.	Ref. No.	Description	Std. Pkg.	Item	Part No.	Ref. No.	Description	Std. Pkg.
1.	T-11271	220747	Shield Cap 45-130A	1	19.	T-9987	220343	Nozzle 200A	1
a 2.	T-11270	220637-UR	Shield Cap 200-400A	1	20.	T-9990	220406	Nozzle 260A	1
3.	T-9975	220202	Shield 45A	10	21.	T-11960	220708	Nozzle 400A (400A, Bevel)	1
4.	T-11954	220815	Shield 60A	10	22.	T-10297	220180	Swirl Ring 30-60A	1
5.	T-9979	220338	Shield 80A	10	23.	T-10295	220179	Swirl Ring 80/130A (130A, Bevel)	1
6.	T-9982	220198	Shield 130A	10	24.	T-10579	220342	Swirl Ring 200A	1
a 7.	T-11956	220762-UR	Shield 200A	1	25.	T-10596	220405	Swirl Ring 260/400A (260/400A, Bevel)	1
a 8.	T-11957	220763-UR	Shield 260A	1	b 26.	T-9978	220308-UR	Electrode 45A	5
a 9.	T-11958	220707-UR	Shield 400A (400A, Bevel)	1	b 27.	T-9981	220339-UR	Electrode 60/80A	5
10.	T-11953	220755	Inner Retaining Cap 45/80/130A	1	b 28.	T-9984	220307-UR	Electrode 130/200/260A	5
11.	T-11951	220814	Inner Retaining Cap 60A	1	b 29.	T-11950	220709-UR	Electrode 400-600A (Bevel)	5
12.	T-11273	220756	Inner Retaining Cap 130A (N ₂)	1	b 30.	T-9882	220340-UR	Cooling Tube 30-260A	1
a 13.	T-11955	220758-UR	Inner Retaining Cap 200/260A	1	b 31.	T-10323	220571-UR	Cooling Tube 400A (260-400A, Bevel)	1
a 14.	T-11959	220712-UR	Inner Retaining Cap 400A (400A, Bevel)	1	32.	TN-0069*	104119-UR	Consumables Removal Tool	1
15.	T-9977	220201	Nozzle 45A	1	33.	T-0994	027055	Silicone Lubricant 25ml	1
16.	T-11952	220847	Nozzle 60A	1	34.	Torch, Cable Leads. See following pages for details.			
17.	T-9980	220337	Nozzle 80A	5	35.	Coolant Liquid. Details on the Accessories page.			
18.	T-9983	220197	Nozzle 130A	5					

* FULLY INTERCHANGEABLE AND COMPATIBLE WITH ORIGINAL PARTS, BUT DIFFERS FROM ORIGINAL DESIGN

a MUST BE USED ONLY AS A SET OF SHIELD, SHIELD CAP AND INNER RETAINING CAP, THIS COMPLETE SET IS INTERCHANGEABLE AND COMPATIBLE WITH ORIGINAL PARTS

b THERMACUT® ELECTRODES HAS TO BE USED WITH THERMACUT® DESIGN COOLING TUBE, OTHERWISE IT DOESN'T FIT TO THE TORCH, THERMACUT® COOLING TUBE CAN BE USED FOR THERMACUT® DESIGN ELECTRODES AND FOR ORIGINAL DESIGN TOO

SMART SOLUTION - DESIGN IMPROVEMENTS THAT BRINGS ADDED VALUE SUCH AS IMPROVED LIFETIME OF CONSUMABLES, EXCELLENT CUT QUALITY, SPEED OR BETTER COST EFFECTIVENESS OF YOUR SYSTEM

THERMACUT®, FHT-EX® AND EX-TRAFIRE® ARE REGISTERED TRADEMARKS OF THERMACUT, K. S. AND MAY BE REGISTERED IN CZECH REPUBLIC AND/OR OTHER COUNTRIES. ALL OTHER TRADEMARKS ARE PROPERTIES OF THEIR RESPECTIVE OWNERS. THERMACUT IS NO WAY AFFILIATED WITH HYPERTHERM®. MOST THERMACUT PARTS ARE MADE FOR OR BY AN IBG COMPANY. PARTS INDICATED WITH A OEM ARE ORIGINAL PARTS MANUFACTURED BY THE ABOVE NAMED MANUFACTURER AND ARE BEING RESOLD BY THERMACUT. THERMACUT RESERVES THE RIGHT TO SUBSTITUTE OEM PARTS IN PLACE OF THERMACUT PARTS. VALID FROM SEPTEMBER 2024 • PREVIOUS VERSION IS NO LONGER VALID. • © COPYRIGHT 2024 BY THERMACUT® CZECH REPUBLIC. ALL RIGHTS RESERVED.

THERMACUT® REPLACEMENT PARTS SUITABLE FOR
Hypertherm®
HyPerformance® Plasma
HPR®130XD/HPR®260XD/HPR®400XD ALUMINIUM

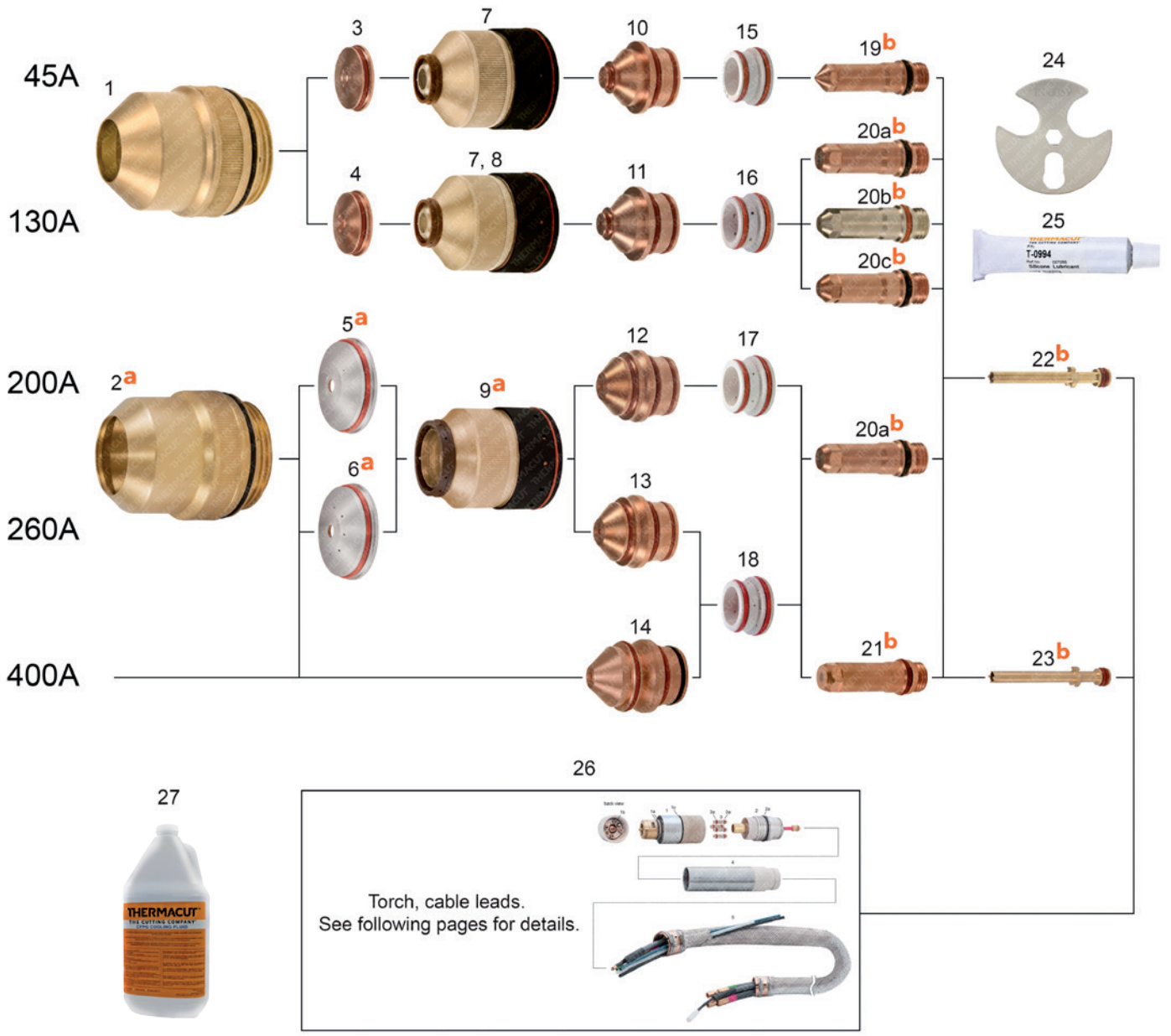

THERMACUT®, FHT-EX® AND EX-TRAFIRE® ARE REGISTERED TRADEMARKS OF THERMACUT, K. S. AND MAY BE REGISTERED IN CZECH REPUBLIC AND/OR OTHER COUNTRIES. ALL OTHER TRADEMARKS ARE PROPERTIES OF THEIR RESPECTIVE OWNERS. THERMACUT IS NO WAY AFFILIATED WITH HYPERTHERM®. MOST THERMACUT PARTS ARE MADE FOR OR BY AN IBC COMPANY. PARTS INDICATED WITH A OEM ARE ORIGINAL PARTS MANUFACTURED BY THE ABOVE NAMED MANUFACTURER AND ARE BEING RESOLD BY THERMACUT. THERMACUT RESERVES THE RIGHT TO SUBSTITUTE OEM PARTS IN PLACE OF THERMACUT PARTS. VALID FROM SEPTEMBER 2024 • PREVIOUS VERSION IS NO LONGER VALID. • © COPYRIGHT 2024 BY THERMACUT® CZECH REPUBLIC. ALL RIGHTS RESERVED.

THERMACUT® REPLACEMENT PARTS SUITABLE FOR
Hypertherm®
HyPerformance® Plasma
HPR®130XD/HPR®260XD/HPR®400XD ALUMINIUM



PRODUCT BROCHURE WITH DETAILS AT
WWW.THERMACUT.COM
 VIDEO AVAILABLE AT YOUTUBE CHANNEL



Item	Part No.	Ref. No.	Description	Std. Pkg.	Item	Part No.	Ref. No.	Description	Std. Pkg.
1.	T-11271	220747	Shield Cap 45-130A	1	17.	T-10579	220342	Swirl Ring 200A	1
a 2.	T-11270	220637-UR	Shield Cap 200-400A	1	18.	T-10596	220405	Swirl Ring 260/400A	1
3.	T-9975	220202	Shield 45A	10	b 19.	T-9978	220308-UR	Electrode 45A	5
4.	T-9982	220198	Shield 130A	10	b 20.c	T-9920	220181-UR	Electrode 130A, Air	5
a 5.	T-11956	220762-UR	Shield 200A	1	b 20.b	T-4917	220181-AG	Electrode 130A, Air, SilverEX-®	5
a 6.	T-11957	220763-UR	Shield 260A	1	b 20.a	T-9984	220307-UR	Electrode 130/200/260A	5
7.	T-11273	220756	Inner Retaining Cap 45/130A	1	b 21.	T-11950	220709-UR	Electrode 400-600A (Bevel)	5
8.	T-11953	220755	Inner Retaining Cap 45/130A	1	b 22.	T-9882	220340-UR	Cooling Tube 30-260A	1
a 9.	T-11955	220758-UR	Inner Retaining Cap 200/260A	1	b 23.	T-10323	220571-UR	Cooling Tube 400A (260-400A, Bevel)	1
10.	T-9977	220201	Nozzle 45A	1	*24.	TN-0069*	104119-UR	Consumables Removal Tool	1
11.	T-9983	220197	Nozzle 130A	5	25.	T-0994	027055	Silicone Lubricant 25ml	1
12.	T-9987	220343	Nozzle 200A	1	26.	Torch, Cable Leads. See following pages for details.			
13.	T-9990	220406	Nozzle 260A	1	27.	Coolant Liquid. Details on the Accessories page.			
14.	T-11960	220708	Nozzle 400A (Bevel)	1					
15.	T-10297	220180	Swirl Ring 30-60A	1					
16.	T-10295	220179	Swirl Ring 130A	1					

* FULLY INTERCHANGEABLE AND COMPATIBLE WITH ORIGINAL PARTS, BUT DIFFERS FROM ORIGINAL DESIGN

a MUST BE USED ONLY AS A SET OF SHIELD, SHIELD CAP AND INNER RETAINING CAP, THIS COMPLETE SET IS INTERCHANGEABLE AND COMPATIBLE WITH ORIGINAL PARTS

b THERMACUT® ELECTRODES HAS TO BE USED WITH THERMACUT® DESIGN COOLING TUBE, OTHERWISE IT DOESN'T FIT TO THE TORCH, THERMACUT® COOLING TUBE CAN BE USED FOR THERMACUT® DESIGN ELECTRODES AND FOR ORIGINAL DESIGN TOO

OEM ORIGINAL PARTS

SMART SOLUTION - DESIGN IMPROVEMENTS THAT BRINGS ADDED VALUE SUCH AS IMPROVED LIFETIME OF CONSUMABLES, EXCELLENT CUT QUALITY, SPEED OR BETTER COST EFFECTIVENESS OF YOUR SYSTEM

THERMACUT®, FHT-EX® AND EX-TRAFIRE® ARE REGISTERED TRADEMARKS OF THERMACUT, K. S. AND MAY BE REGISTERED IN CZECH REPUBLIC AND/OR OTHER COUNTRIES. ALL OTHER TRADEMARKS ARE PROPERTIES OF THEIR RESPECTIVE OWNERS. THERMACUT IS NO WAY AFFILIATED WITH HYPERTHERM®.

MOST THERMACUT PARTS ARE MADE FOR OR BY AN IBG COMPANY. PARTS INDICATED WITH A OEM ARE ORIGINAL PARTS MANUFACTURED BY THE ABOVE NAMED MANUFACTURER AND ARE BEING RESOLD BY THERMACUT. THERMACUT RESERVES THE RIGHT TO SUBSTITUTE OEM PARTS IN PLACE OF THERMACUT PARTS.

VALID FROM SEPTEMBER 2024 • PREVIOUS VERSION IS NO LONGER VALID. • © COPYRIGHT 2024 BY THERMACUT® CZECH REPUBLIC. ALL RIGHTS RESERVED.

**THERMACUT® REPLACEMENT PARTS SUITABLE FOR
Hypertherm®
HPR® 130XD/HPR® 260XD/HPR® 400XD | TORCHES AND CABLE LEADS**

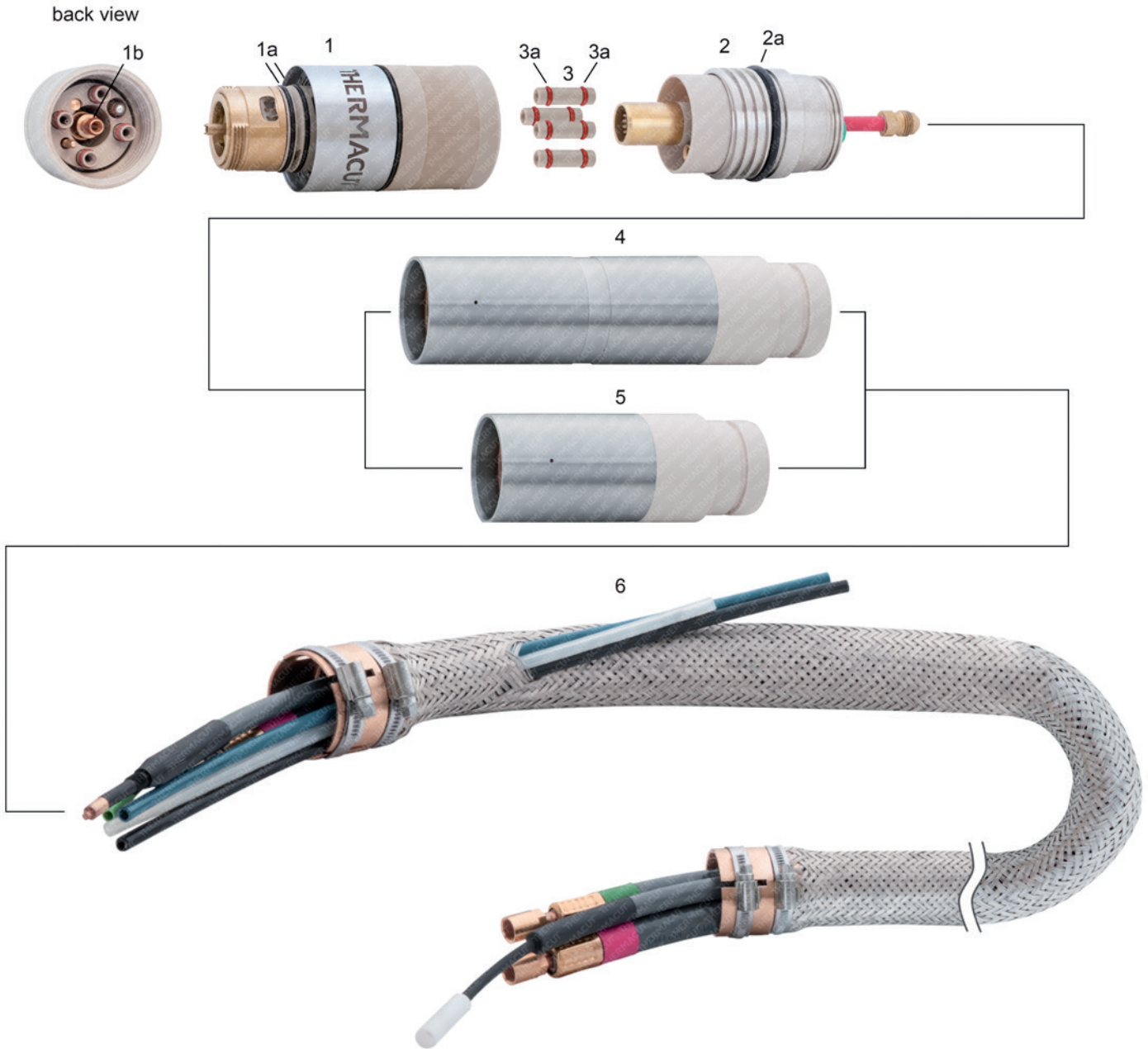

THERMACUT®, FHT-EX® AND EX-TRAFIRE® ARE REGISTERED TRADEMARKS OF THERMACUT, K. S. AND MAY BE REGISTERED IN CZECH REPUBLIC AND/OR OTHER COUNTRIES. ALL OTHER TRADEMARKS ARE PROPERTIES OF THEIR RESPECTIVE OWNERS. THERMACUT IS NO WAY AFFILIATED WITH HYPERTHERM®. MOST THERMACUT PARTS ARE MADE FOR OR BY AN IBG COMPANY. PARTS INDICATED WITH A OEM ARE ORIGINAL PARTS MANUFACTURED BY THE ABOVE NAMED MANUFACTURER AND ARE BEING RESOLD BY THERMACUT. THERMACUT RESERVES THE RIGHT TO SUBSTITUTE OEM PARTS IN PLACE OF THERMACUT PARTS. VALID FROM SEPTEMBER 2024 • PREVIOUS VERSION IS NO LONGER VALID. • © COPYRIGHT 2024 BY THERMACUT® CZECH REPUBLIC. ALL RIGHTS RESERVED.

**THERMACUT® REPLACEMENT PARTS SUITABLE FOR
Hypertherm®
HPR®130XD/HPR®260XD/HPR®400XD | TORCHES AND CABLE LEADS**

Item	Part No.	Ref. No.	Description	Std. Pkg.	Item	Part No.	Ref. No.	Description	Std. Pkg.
1.	T-11834	220706	Torch Q. D. (included items 1a, 1b and 2 pcs. of Cooling Tube 220340-UR)	1	NS	T-13114	228514	Robo Leads 2m (6ft) w/ Gas Hose 1.8m (6ft)	1
1a.	N-10096	1-028B	O-Ring	1	NS	T-13116	228516	Robo Leads 2m (6ft) w/ Gas Hose 2.4m (8ft)	1
1b.	N-10054	1-008S	O-Ring	1	NS	T-13115	228515	Robo Leads 2.5m (8ft) w/ Gas Hose 1.8m (6ft)	1
2.	T-11844	220705	Receptacle Q. D.	1	NS	T-13117	228517	Robo Leads 2.5m (8ft) w/ Gas Hose 2.4m (8ft)	1
2a.	N-18108	O-KR-45x3,5B	O-Ring	1	NS	T-13100	228475	Robo Leads 3m (10ft) w/ Gas Hose 1.8m (6ft)	1
3.	T-11769	T-11769	Connector Tube HPR with O-Rings	1	NS	T-13107	228482	Robo Leads 3m (10ft) w/ Gas Hose 2.4m (8ft)	1
3a.	N-10055	1-009S	O-Ring	1	NS	T-13101	228476	Robo Leads 3.5m (12ft) w/ Gas Hose 1.8m (6ft)	1
4.	T-11854	220789	Mounting Sleeve XD	1	NS	T-13108	228483	Robo Leads 3.5m (12ft) w/ Gas Hose 2.4m (8ft)	1
5.	T-12226	220788	Mounting Sleeve XD, Short	1	NS	T-13102	228477	Robo Leads 4.5m (15ft) w/ Gas Hose 1.8m (6ft)	1
16.	KT-1423	228291	Cable Leads 2m(6ft) w/ Gas Hose 1.8m(6ft)	1	NS	T-13109	228484	Robo Leads 4.5m (15ft) w/ Gas Hose 2.4m (8ft)	1
!	KT-1440	228410	Cable Leads 2m(6ft) w/ Gas Hose 2.4m(8ft)	1	NS	T-13103	228478	Robo Leads 6m (20ft) w/ Gas Hose 1.8m (6ft)	1
!	KT-1424	228292	Cable Leads 3m(10ft) w/ Gas Hose 1.8m(6ft)	1	NS	T-13110	228485	Robo Leads 6m (20ft) w/ Gas Hose 2.4m (8ft)	1
!	KT-1439	228411	Cable Leads 3m(10ft) w/ Gas Hose 2.4m(8ft)	1	NS	T-13104	228479	Robo Leads 7.5m (25ft) w/ Gas Hose 1.8m (6ft)	1
!	KT-1425	228293	Cable Leads 4.5m(15ft) w/ Gas Hose 1.8m(6ft)	1	NS	T-13111	228486	Robo Leads 7.5m (25ft) w/ Gas Hose 2.4m (8ft)	1
!	KT-1438	228412	Cable Leads 4.5m(15ft) w/ Gas Hose 2.4m(8ft)	1	NS	T-13105	228480	Robo Leads 10m (35ft) w/ Gas Hose 1.8m (6ft)	1
!	KT-1426	228294	Cable Leads 6m(20ft) w/ Gas Hose 1.8m(6ft)	1	NS	T-13112	228487	Robo Leads 10m (35ft) w/ Gas Hose 2.4m (8ft)	1
!	KT-1441	228413	Cable Leads 6m(20ft) w/ gas hose 2.4m(8ft)	1	NS	T-13106	228481	Robo Leads 15m (50ft) w/ Gas Hose 1.8m (6ft)	1
!	KT-1427	228295	Cable Leads 7.5m(25ft) w/ Gas Hose 1.8m(6ft)	1	NS	T-13113	228488	Robo Leads 15m (50ft) w/ Gas Hose 2.4m (8ft)	1
!	KT-1442	228414	Cable Leads 7.5m(25ft) w/ Gas Hose 2.4m(8ft)	1	More types of cable leads are available on request				
!	KT-1428	228296	Cable Leads 10m(35ft) w/ Gas Hose 1.8m(6ft)	1	Torch Kit - set of spare parts for 220706, contains items 3 (4 pcs.), 3a (8 pcs.), 1a (2 pcs.), 1b (1 pc.), 1c (1 pc.), 2a (1 pc.), Cooling Tube 220340-UR, Silicone Lubricant T-0994				
!	KT-1437	228415	Cable Leads 10m(35ft) w/ Gas Hose 2.4m(8ft)	1					
!	KT-1429	228297	Cable Leads 15m(50ft) w/ Gas Hose 1.8m(6ft)	1					
!	KT-1436	228416	Cable Leads 15m(50ft) w/ Gas Hose 2.4m(8ft)	1					
!	KT-1430	228547	Cable Leads 20m(65ft) w/ Gas Hose 1.8m(6ft)	1					
!	KT-1434	228546	Cable Leads 20m(65ft) w/ Gas Hose 2.4m(8ft)	1	Torch with leads available on request				

! OHMIC CONTACT WIRE IS NOT PART OF THE CABLE LEADS

NS NOT SHOWN IN THE PICTURE

Q. D. QUICK DISCONNECT

ALL PARTS ARE WITH O-RINGS

W/ WITH

THERMACUT®, FHT-EX® AND EX-TRAFIRE® ARE REGISTERED TRADEMARKS OF THERMACUT, K. S. AND MAY BE REGISTERED IN CZECH REPUBLIC AND/OR OTHER COUNTRIES. ALL OTHER TRADEMARKS ARE PROPERTIES OF THEIR RESPECTIVE OWNERS. THERMACUT IS NO WAY AFFILIATED WITH HYPERTHERM®. MOST THERMACUT PARTS ARE MADE FOR OR BY AN IBG COMPANY. PARTS INDICATED WITH A OEM ARE ORIGINAL PARTS MANUFACTURED BY THE ABOVE NAMED MANUFACTURER AND ARE BEING RESOLD BY THERMACUT. THERMACUT RESERVES THE RIGHT TO SUBSTITUTE OEM PARTS IN PLACE OF THERMACUT PARTS. VALID FROM SEPTEMBER 2024 • PREVIOUS VERSION IS NO LONGER VALID. • © COPYRIGHT 2024 BY THERMACUT® CZECH REPUBLIC. ALL RIGHTS RESERVED.

THERMACUT® REPLACEMENT PARTS SUITABLE FOR
Hypertherm®
HySpeed® Plasma | HSD®130 MILD STEEL

PRODUCT BROCHURE WITH DETAILS AT
WWW.THERMACUT.COM

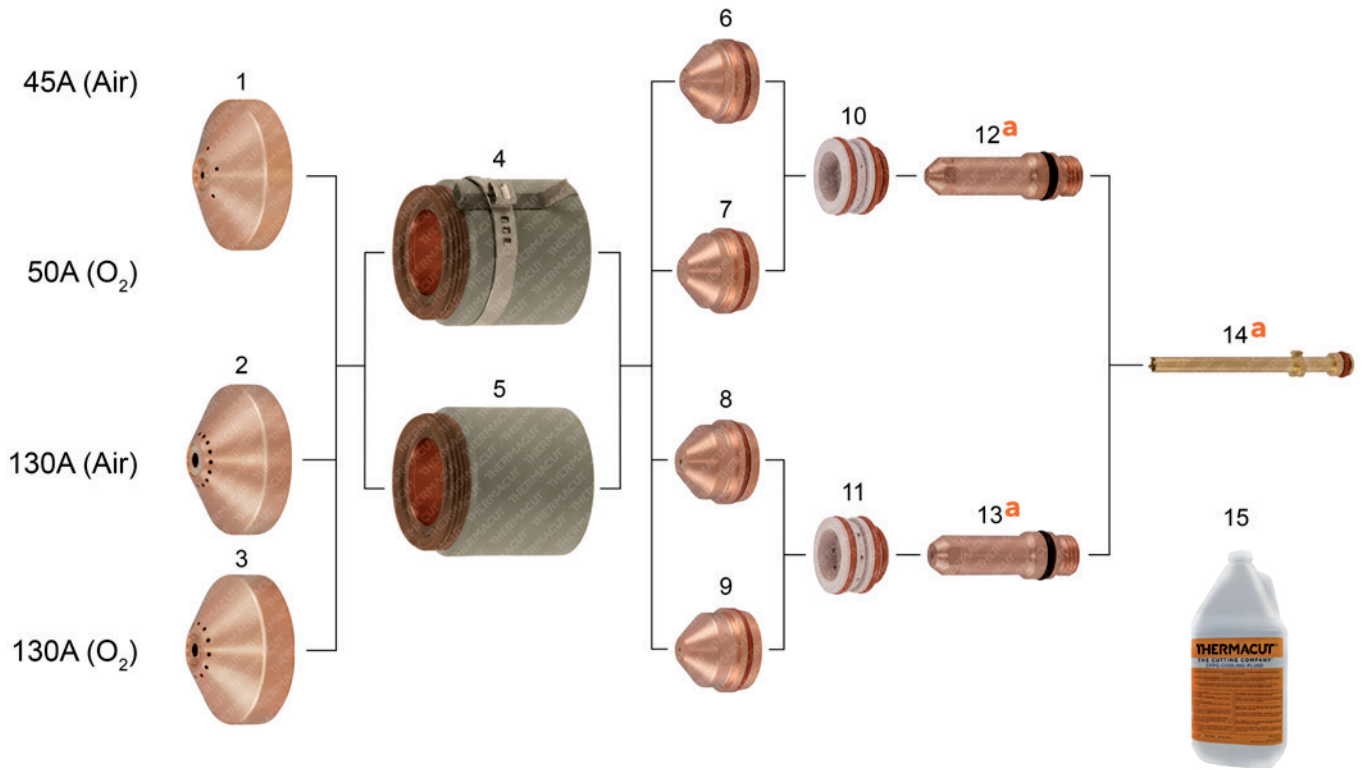

Item	Part No.	Ref. No.	Description	Std. Pkg.	Item	Part No.	Ref. No.	Description	Std. Pkg.
1.	T-11283	220532	Shield 45A, Air (50A, O ₂)	1	9.	T-11305	220489	Nozzle 130A, O ₂	5
2.	T-11284	220536	Shield 130A, Air	1	10.	T-11282	220529	Swirl Ring 45A, Air (50A, O ₂)	1
3.	T-11281	220491	Shield 130A, O ₂	1	11.	T-11280	220488	Swirl Ring 130A (200A)	1
4.	T-13095	220578	Ret. Cap 45/130A, Air (50/130A, O ₂), with IHS	1	a 12.	T-11309	220528-UR	Electrode 45A (50A)	5
5.	T-13094	220490	Ret. Cap 45/130A, Air (50/130A, O ₂), without IHS	1	a 13.	T-11304	220487-UR	Electrode 130A, Air/O ₂	5
6.	T-11308	220525	Nozzle 45A, Air	5	a 14.	T-11307	220521-UR	Cooling Tube	1
7.	T-11311	220530	Nozzle 50A, O ₂	5	15.			Coolant Liquid. Details on the Accessories page.	
8.	T-11306	220492	Nozzle 130A, Air	5					

* FULLY INTERCHANGEABLE WITH ORIGINAL PARTS, BUT DIFFERS FROM ORIGINAL DESIGN

a THERMACUT® ELECTRODES HAS TO BE USED WITH THERMACUT® DESIGN COOLING TUBE, OTHERWISE IT DOESN'T FIT TO THE TORCH, THERMACUT® COOLING TUBE CAN BE USED FOR THERMACUT® DESIGN ELECTRODES AND FOR ORIGINAL DESIGN TOO.

THERMACUT®, FHT-EX® AND EX-TRAFIRE® ARE REGISTERED TRADEMARKS OF THERMACUT, K. S. AND MAY BE REGISTERED IN CZECH REPUBLIC AND/OR OTHER COUNTRIES. ALL OTHER TRADEMARKS ARE PROPERTIES OF THEIR RESPECTIVE OWNERS. THERMACUT IS NO WAY AFFILIATED WITH HYPERTHERM®. MOST THERMACUT PARTS ARE MADE FOR OR BY AN IBG COMPANY. PARTS INDICATED WITH A OEM ARE ORIGINAL PARTS MANUFACTURED BY THE ABOVE NAMED MANUFACTURER AND ARE BEING RESOLD BY THERMACUT. THERMACUT RESERVES THE RIGHT TO SUBSTITUTE OEM PARTS IN PLACE OF THERMACUT PARTS. VALID FROM SEPTEMBER 2024 • PREVIOUS VERSION IS NO LONGER VALID. • © COPYRIGHT 2024 BY THERMACUT® CZECH REPUBLIC. ALL RIGHTS RESERVED.

**THERMACUT® REPLACEMENT PARTS SUITABLE FOR
Hypertherm®
HySpeed® Plasma | HSD®130 STAINLESS STEEL**

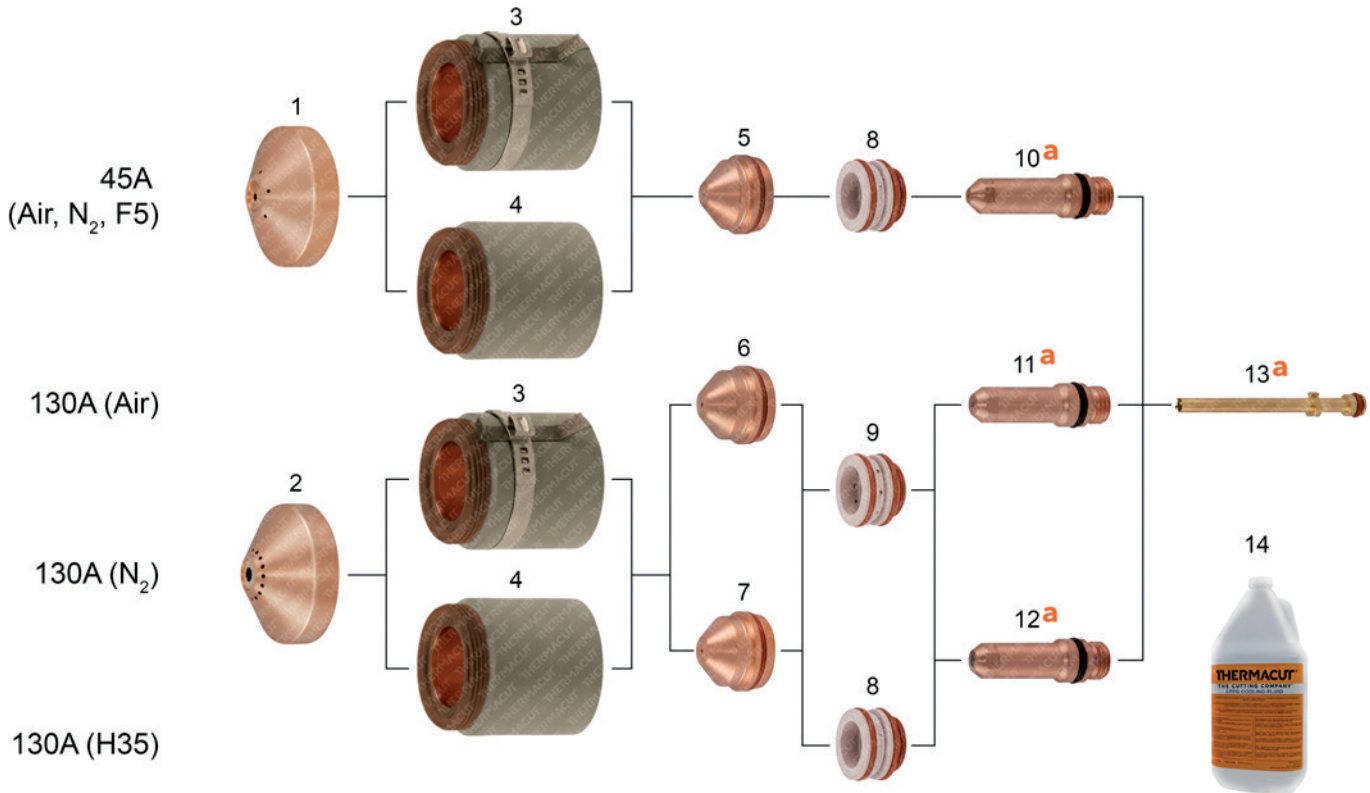

Item	Part No.	Ref. No.	Description	Std. Pkg.	Item	Part No.	Ref. No.	Description	Std. Pkg.
1.	T-11283	220532	Shield 45A, Air/N ₂ /F5	1	9.	T-11280	220488	Swirl Ring 130A (200A)	1
2.	T-11284	220536	Shield 130A, Air/H35/N ₂	1	a10.	T-11309	220528-UR	Electrode 45A (50A)	5
3.	T-13095	220578	Ret. Cap 45A, Air (130A, Air/N ₂), with IHS	1	a11.	T-11304	220487-UR	Electrode 130A, Air	5
4.	T-13094	220490	Ret. Cap 45A, Air (130A, Air/N ₂), without IHS	1	a12.	T-0382	020415-UR	Electrode 100-200A	5
5.	T-11308	220525	Nozzle 45A, Air/N ₂ /F5	5	a13.	T-11307	220521-UR	Cooling Tube	1
6.	T-11306	220492	Nozzle 130A, Air	5	14.			Coolant Liquid. Details on the Accessories page.	
OD 7.	T-11310	220535	Nozzle 130A, H35/N ₂	5					
8.	T-11282	220529	Swirl Ring 45A, Air/N ₂ /F5 (130A, H35)	1					

* FULLY INTERCHANGEABLE WITH ORIGINAL PARTS, BUT DIFFERS FROM ORIGINAL DESIGN

a THERMACUT® ELECTRODES HAS TO BE USED WITH THERMACUT® DESIGN COOLING TUBE, OTHERWISE IT DOESN'T FIT TO THE TORCH, THERMACUT® COOLING TUBE CAN BE USED FOR THERMACUT® DESIGN ELECTRODES AND FOR ORIGINAL DESIGN TOO.

OD ON DEMAND – WE DO NOT KEEP THESE PARTS IN STOCK, COST IS SET ACCORDING TO THE ORDERED QUANTITY, DELIVERY TIME MAY DIFFER FROM STANDARD PRODUCTS.

THERMACUT®, FHT-EX® AND EX-TRAFIRE® ARE REGISTERED TRADEMARKS OF THERMACUT, K. S. AND MAY BE REGISTERED IN CZECH REPUBLIC AND/OR OTHER COUNTRIES. ALL OTHER TRADEMARKS ARE PROPERTIES OF THEIR RESPECTIVE OWNERS. THERMACUT IS NO WAY AFFILIATED WITH HYPERTHERM®. MOST THERMACUT PARTS ARE MADE FOR OR BY AN IBG COMPANY. PARTS INDICATED WITH A OEM ARE ORIGINAL PARTS MANUFACTURED BY THE ABOVE NAMED MANUFACTURER AND ARE BEING RESOLD BY THERMACUT. THERMACUT RESERVES THE RIGHT TO SUBSTITUTE OEM PARTS IN PLACE OF THERMACUT PARTS. VALID FROM SEPTEMBER 2024 • PREVIOUS VERSION IS NO LONGER VALID. • © COPYRIGHT 2024 BY THERMACUT® CZECH REPUBLIC. ALL RIGHTS RESERVED.

THERMACUT® REPLACEMENT PARTS SUITABLE FOR
Hypertherm®
HySpeed® Plasma | HSD®130 ALUMINIUM

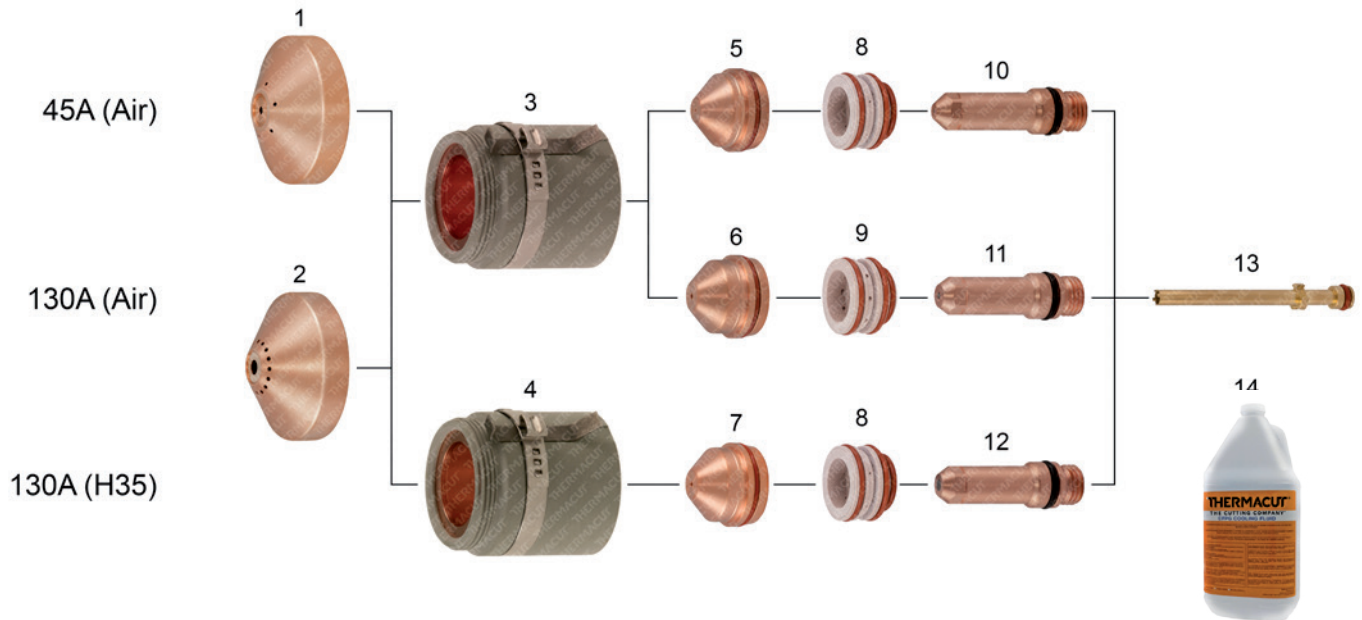

Item	Part No.	Ref. No.	Description	Std. Pkg.	Item	Part No.	Ref. No.	Description	Std. Pkg.
1.	T-11283	220532	Shield 45A, Air	1	9.	T-11280	220488	Swirl Ring 130A (200A)	1
2.	T-11284	220536	Shield 130A, Air/H35	1	a10.	T-11309	220528-UR	Electrode 45A (50A)	5
3.	T-13095	220578	Retaining Cap 45/130A, Air, with IHS	1	a11.	T-11304	220487-UR	Electrode 130A, Air	5
4.	T-13094	220490	Retaining Cap 45/130A, Air, without IHS	1	a12.	T-0382	020415-UR	Electrode 100-200A	5
5.	T-11308	220525	Nozzle 45A, Air	5	a13.	T-11307	220521-UR	Cooling Tube	1
6.	T-11306	220492	Nozzle 130A, Air	5	14.	Coolant Liquid. Details on the Accessories page.			
OD 7.	T-11310	220535	Nozzle 130A, H35	5	15.		220534 OEM	Ret. Cap 45A N ₂ /F5, 130A H35 w/ IHS	1
8.	T-11282	220529	Swirl Ring 45A, Air (130A, H35)	1			220533 OEM	Ret. Cap 45A N ₂ /F5, 130A H35 w/o IHS	1

* FULLY INTERCHANGEABLE WITH ORIGINAL PARTS, BUT DIFFERS FROM ORIGINAL DESIGN

a THERMACUT® ELECTRODES HAS TO BE USED WITH THERMACUT® DESIGN COOLING TUBE, OTHERWISE IT DOESN'T FIT TO THE TORCH, THERMACUT® COOLING TUBE CAN BE USED FOR THERMACUT® DESIGN ELECTRODES AND FOR ORIGINAL DESIGN TOO.

OD ON DEMAND – WE DO NOT KEEP THESE PARTS IN STOCK, COST IS SET ACCORDING TO THE ORDERED QUANTITY, DELIVERY TIME MAY DIFFER FROM STANDARD PRODUCTS.

W/ WITH

W/O WITHOUT

THERMACUT®, FHT-EX® AND EX-TRAFIRE® ARE REGISTERED TRADEMARKS OF THERMACUT, K. S. AND MAY BE REGISTERED IN CZECH REPUBLIC AND/OR OTHER COUNTRIES. ALL OTHER TRADEMARKS ARE PROPERTIES OF THEIR RESPECTIVE OWNERS. THERMACUT IS NO WAY AFFILIATED WITH HYPERTHERM®. MOST THERMACUT PARTS ARE MADE FOR OR BY AN IBG COMPANY. PARTS INDICATED WITH A OEM ARE ORIGINAL PARTS MANUFACTURED BY THE ABOVE NAMED MANUFACTURER AND ARE BEING RESOLD BY THERMACUT. THERMACUT RESERVES THE RIGHT TO SUBSTITUTE OEM PARTS IN PLACE OF THERMACUT PARTS. VALID FROM SEPTEMBER 2024 • PREVIOUS VERSION IS NO LONGER VALID. • © COPYRIGHT 2024 BY THERMACUT® CZECH REPUBLIC. ALL RIGHTS RESERVED.

THERMACUT® REPLACEMENT PARTS SUITABLE FOR
Hypertherm®
HyPerformance® Plasma | XPR® 170/300

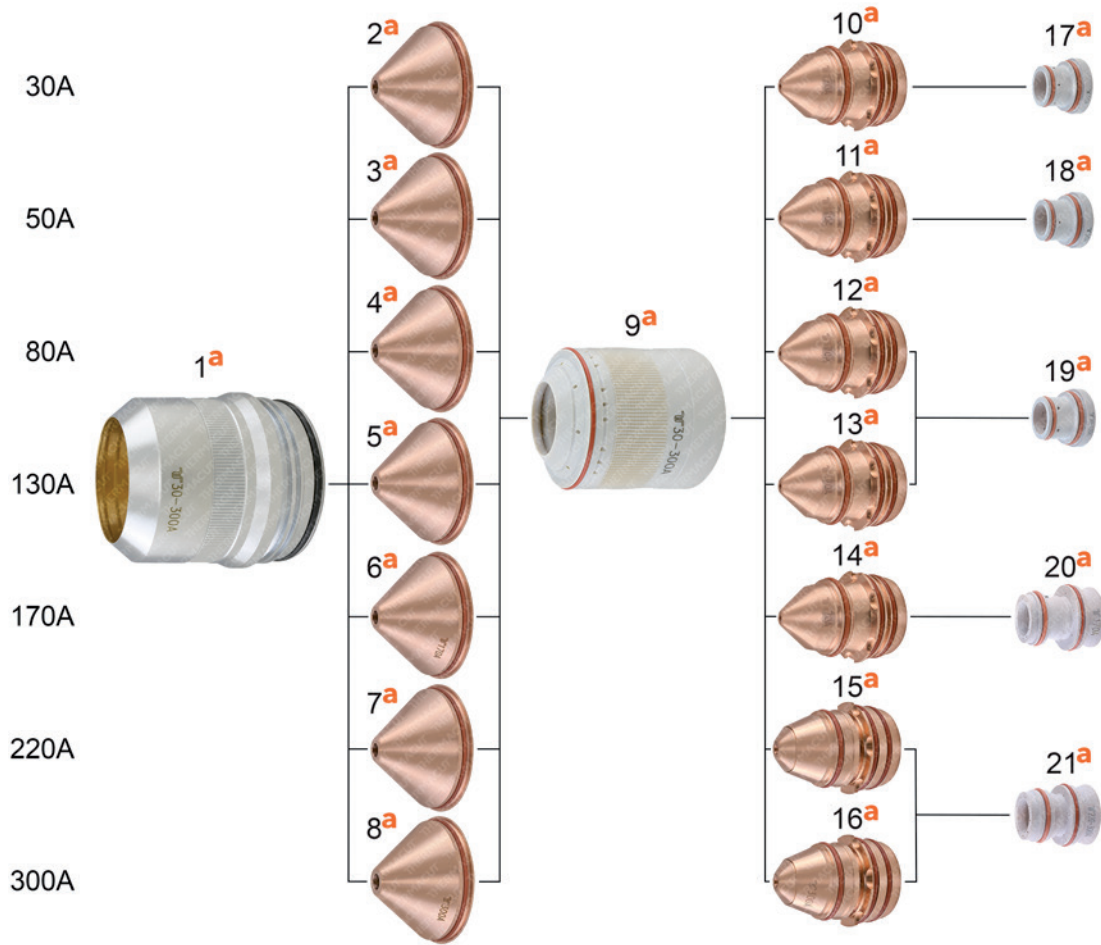

Item	Part No.	Ref. No.	Description	Std. Pkg.	Item	Part No.	Ref. No.	Description	Std. Pkg.
a 1.	T-13241	420200-UR	Shield Cap 30-300A	1	a 13.	T-13291	420252-UR	Nozzle 130A	1
a 2.	T-13297	420228-UR	Shield 30A	1	a 14.	T-13244	420261-UR	Nozzle 170A	1
a 3.	T-13300	420237-UR	Shield 50A	1	a*15.	T-13321*	420270-UR	Nozzle 220A	1
a 4.	T-13289	420246-UR	Shield 80A	1	a 16.	T-13245	420279-UR	Nozzle 300A	1
a 5.	T-13290	420255-UR	Shield 130A	1	a 17.	T-13301	420407-UR	Swirl Ring 30A	1
a 6.	T-13247	420513-UR	Shield 170A	1	a 18.	T-13298	420233-UR	Swirl Ring 50A	1
a 7.	T-13322	420273-UR	Shield 220A	1	a 19.	T-13287	420242-UR	Swirl Ring 80-130A	1
a 8.	T-13246	420491-UR	Shield 300A	1	a 20.	T-13242	420260-UR	Swirl Ring 170A	1
a 9.	T-13258	420365-UR	Retaining Cap 30-300A	1	a 21.	T-13243	420406-UR	Swirl Ring 220-300A	1
a 10.	T-13296	420225-UR	Nozzle 30A	1					
a 11.	T-13299	420234-UR	Nozzle 50A	1					
a 12.	T-13288	420243-UR	Nozzle 80A	1					

* COMING SOON

a MUST BE USED ONLY AS A SET OF ALL PARTS, THIS COMPLETE SET CAN BE USED INTO ORIGINAL TORCH BODY.

THERMACUT®, FHT-EX® AND EX-TRAFIRE® ARE REGISTERED TRADEMARKS OF THERMACUT, K. S. AND MAY BE REGISTERED IN CZECH REPUBLIC AND/OR OTHER COUNTRIES. ALL OTHER TRADEMARKS ARE PROPERTIES OF THEIR RESPECTIVE OWNERS. THERMACUT IS NO WAY AFFILIATED WITH HYPERTHERM®. MOST THERMACUT PARTS ARE MADE FOR OR BY AN IBG COMPANY. PARTS INDICATED WITH A OEM ARE ORIGINAL PARTS MANUFACTURED BY THE ABOVE NAMED MANUFACTURER AND ARE BEING RESOLD BY THERMACUT. THERMACUT RESERVES THE RIGHT TO SUBSTITUTE OEM PARTS IN PLACE OF THERMACUT PARTS. VALID FROM SEPTEMBER 2024 • PREVIOUS VERSION IS NO LONGER VALID. • © COPYRIGHT 2024 BY THERMACUT® CZECH REPUBLIC. ALL RIGHTS RESERVED.

**THERMACUT® REPLACEMENT PARTS SUITABLE FOR
KALIBURN®**

SPIRIT®, ProLine™

SPIRIT® 150a, 200a, 275a, 400a, ProLine™ 2150, 2200, 2260 MILD STEEL

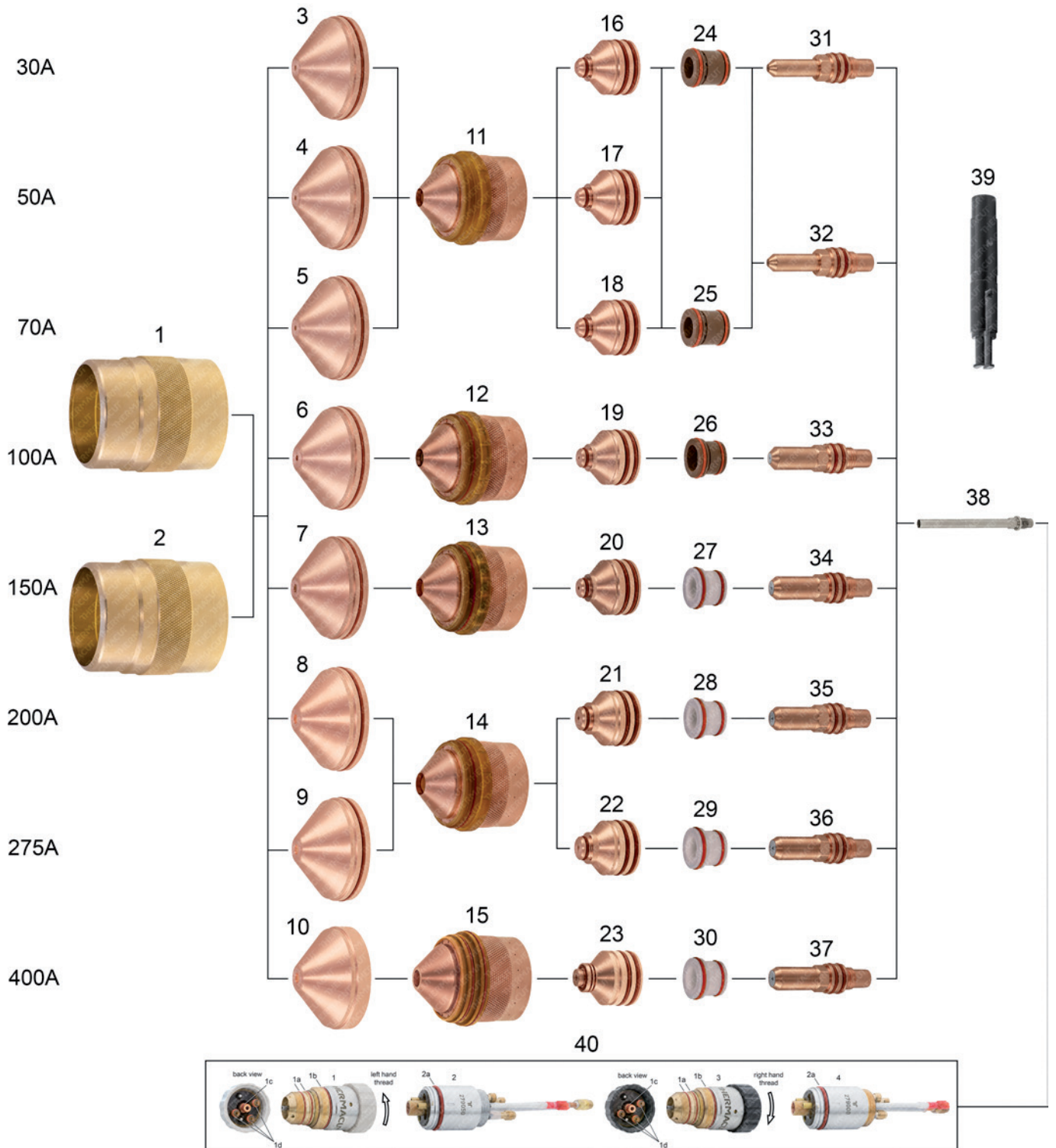

THERMACUT®, FHT-EX® AND EX-TRAFIRE® ARE REGISTERED TRADEMARKS OF THERMACUT, K. S. AND MAY BE REGISTERED IN CZECH REPUBLIC AND/OR OTHER COUNTRIES. ALL OTHER TRADEMARKS ARE PROPERTIES OF THEIR RESPECTIVE OWNERS. THERMACUT IS NO WAY AFFILIATED WITH KALIBURN®. MOST THERMACUT PARTS ARE MADE FOR OR BY AN IBG COMPANY. PARTS INDICATED WITH A OEM ARE ORIGINAL PARTS MANUFACTURED BY THE ABOVE NAMED MANUFACTURER AND ARE BEING RESOLD BY THERMACUT. THERMACUT RESERVES THE RIGHT TO SUBSTITUTE OEM PARTS IN PLACE OF THERMACUT PARTS. VALID FROM SEPTEMBER 2024 • PREVIOUS VERSION IS NO LONGER VALID. • © COPYRIGHT 2024 BY THERMACUT® CZECH REPUBLIC. ALL RIGHTS RESERVED.

THERMACUT® REPLACEMENT PARTS SUITABLE FOR KALIBURN®

SPIRIT®, ProLine™

SPIRIT® 150a, 200a, 275a, 400a, ProLine™ 2150, 2200, 2260 MILD STEEL



PRODUCT BROCHURE WITH DETAILS AT
WWW.THERMACUT.COM

Item	Part No.	Ref. No.	Description	Std. Pkg.	Item	Part No.	Ref. No.	Description	Std. Pkg.
1.	T-11909	284150	Outer Retaining Cap 30-400A	1	21.	T-11884	277289	Nozzle 200A MS/SS/AL, Air	1
2.	T-11892	277154	Outer Retaining Cap 30-275A	1	22.	T-11888	277269	Nozzle 275A MS	1
3.	T-12034	277145	Shield Cap 30A MS/AL	1	23.	T-12028	284125	Nozzle 400A MS	5
4.	T-12029	277115	Shield Cap 50A MS	1	24.	T-12033	277140	Swirl Ring 30-70A MS/SS/AL, H17	1
5.	T-11901	277150	Shield Cap 70A MS/SS/AL	1	25.	T-11894	277142	Swirl Ring 50-70A MS/SS/AL	1
6.	T-11898	277286	Shield Cap 100A MS/SS/AL, Air	1	26.	T-11893	277283	Swirl Ring 100A MS/SS/AL, Air	1
7.	T-11907	277117	Shield Cap 150A MS/SS/AL	1	*27.	T-11897	277139-UR	Swirl Ring 150A MS/SS/AL	1
8.	T-11899	277274	Shield Cap 200A MS/SS/AL	1	*28.	T-11896	277143-UR	Swirl Ring 200A MS/SS/AL	1
9.	T-11900	277263	Shield Cap 275A MS/SS/AL	1	*29.	T-11895	277258-UR	Swirl Ring 275A MS/SS/AL	1
10.	T-12037	284123	Shield Cap 400A MS	1	*30.	T-12036	284122-UR	Swirl Ring 400A MS/SS/AL	1
11.	T-11891	277153	Inner Retaining Cap 30-70A MS/SS/AL	1	31.	T-12032	277130	Electrode 30A MS/AL	5
12.	T-11908	277151	Inner Retaining Cap 100/150A MS/SS/AL	1	32.	T-11906	277131	Electrode 50/70A MS/SS/AL	5
13.	T-11890	277152	Inner Retaining Cap 150A MS/SS/AL	1	33.	T-11902	277282-PRO	Electrode 100A MS/SS/AL, Silver PRO	5
14.	T-11889	277266	Inner Retaining Cap 200/275A MS/SS/AL	1	34.	T-11904	277292-PRO	Electrode 150A MS/SS/AL, Silver PRO	5
15.	T-12035	284121	Inner Retaining Cap 400A MS	1	35.	T-11903	277291-PRO	Electrode 200A MS/SS/AL, Silver PRO	5
16.	T-12030	277120	Nozzle 30A MS/AL	1	36.	T-11905	277270-PRO	Electrode 275A MS/SS/AL, Silver PRO	5
17.	T-12031	277122	Nozzle 50A MS/AL	1	37.	T-12038	284124-PRO	Electrode 400A MS, Silver PRO	5
18.	T-11887	277125	Nozzle 70A MS/SS/AL	1	38.	T-11944	277007	Cooling Tube	1
19.	T-11886	277284	Nozzle 100A MS/SS/AL, Air	1	39.	T-11322	12.40320	Wrench for Swirl Ring 150-400A	1
20.	T-11885	277293	Nozzle 150A MS/SS/AL, Air	1	40.	Torches. See following pages for details.			

* FULLY INTERCHANGEABLE AND COMPATIBLE WITH ORIGINAL PARTS, BUT DIFFERS FROM ORIGINAL DESIGN

-PRO SILVER PRO TECHNOLOGY INCREASES ELECTRODE LIFETIME SIGNIFICANTLY COMPARED TO STANDARD COPPER ELECTRODES

THERMACUT®, FHT-EX® AND EX-TRAFIRE® ARE REGISTERED TRADEMARKS OF THERMACUT, K. S. AND MAY BE REGISTERED IN CZECH REPUBLIC AND/OR OTHER COUNTRIES. ALL OTHER TRADEMARKS ARE PROPERTIES OF THEIR RESPECTIVE OWNERS. THERMACUT IS NO WAY AFFILIATED WITH KALIBURN®. MOST THERMACUT PARTS ARE MADE FOR OR BY AN IBG COMPANY. PARTS INDICATED WITH A OEM ARE ORIGINAL PARTS MANUFACTURED BY THE ABOVE NAMED MANUFACTURER AND ARE BEING RESOLD BY THERMACUT. THERMACUT RESERVES THE RIGHT TO SUBSTITUTE OEM PARTS IN PLACE OF THERMACUT PARTS. VALID FROM SEPTEMBER 2024 • PREVIOUS VERSION IS NO LONGER VALID. • © COPYRIGHT 2024 BY THERMACUT® CZECH REPUBLIC. ALL RIGHTS RESERVED.

**THERMACUT® REPLACEMENT PARTS SUITABLE FOR
KALIBURN®**

SPIRIT®, ProLine™

SPIRIT® 150a, 200a, 275a, 400a, ProLine™ 2150, 2200, 2260 STAINLESS STEEL

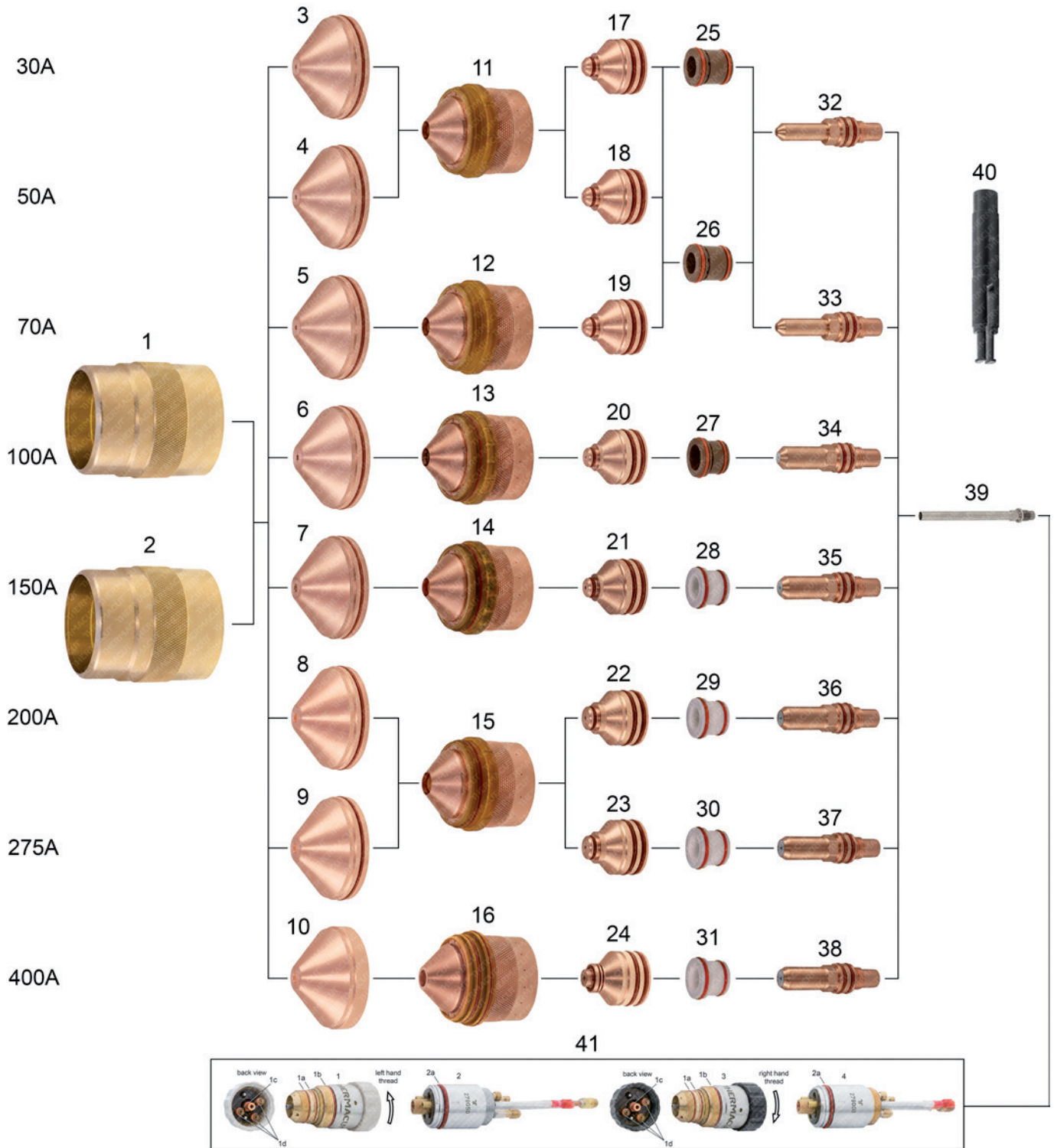

THERMACUT®, FHT-EX® AND EX-TRAFIRE® ARE REGISTERED TRADEMARKS OF THERMACUT, K. S. AND MAY BE REGISTERED IN CZECH REPUBLIC AND/OR OTHER COUNTRIES. ALL OTHER TRADEMARKS ARE PROPERTIES OF THEIR RESPECTIVE OWNERS. THERMACUT IS NO WAY AFFILIATED WITH KALIBURN®. MOST THERMACUT PARTS ARE MADE FOR OR BY AN IBG COMPANY. PARTS INDICATED WITH A OEM ARE ORIGINAL PARTS MANUFACTURED BY THE ABOVE NAMED MANUFACTURER AND ARE BEING RESOLD BY THERMACUT. THERMACUT RESERVES THE RIGHT TO SUBSTITUTE OEM PARTS IN PLACE OF THERMACUT PARTS. VALID FROM SEPTEMBER 2024 • PREVIOUS VERSION IS NO LONGER VALID. • © COPYRIGHT 2024 BY THERMACUT® CZECH REPUBLIC. ALL RIGHTS RESERVED.

THERMACUT® REPLACEMENT PARTS SUITABLE FOR KALIBURN®

SPIRIT®, ProLine™

SPIRIT® 150a, 200a, 275a, 400a, ProLine™ 2150, 2200, 2260 STAINLESS STEEL



PRODUCT BROCHURE WITH DETAILS AT
WWW.THERMACUT.COM

Item	Part No.	Ref. No.	Description	Std. Pkg.	Item	Part No.	Ref. No.	Description	Std. Pkg.
1.	T-11909	284150	Outer Retaining Cap 30-400A	1	23.	T-12056	277276	Nozzle 275A SS/AL	1
2.	T-11892	277154	Outer Retaining Cap 30-275A	1	OD 24.	T-12057	284157	Nozzle 400A SS	1
3.	T-12049	277144	Shield Cap 30A SS	1	25.	T-12059	277138	Swirl Ring 30A SS	1
4.	T-12050	277149	Shield Cap 50A SS	1	26.	T-11894	277142	Swirl Ring 50/70A MS/SS/AL	1
5.	T-11901	277150	Shield Cap 70A MS/SS/AL	1	*27.	T-11893	277283	Swirl Ring 100A MS/SS/AL, Air	1
6.	T-11898	277286	Shield Cap 100A MS/SS/AL, Air	1	*28.	T-11897	277139-UR	Swirl Ring 150A MS/SS/AL	1
7.	T-11907	277117	Shield Cap 150A MS/SS/AL	1	*29.	T-11896	277143-UR	Swirl Ring 200A MS/SS/AL	1
8.	T-11899	277274	Shield Cap 200A MS/SS/AL	1	*30.	T-11895	277258-UR	Swirl Ring 275A MS/SS/AL	1
9.	T-11900	277263	Shield Cap 275A MS/SS/AL	1	31.	T-12036	284122-UR	Swirl Ring 400A MS/SS/AL	1
10.	T-12051	284155	Shield Cap 400A SS/AL	1	32.	T-12060	277137	Electrode 30/50A SS	10
11.	T-12052	277110	Inner Retaining Cap 30-50A SS	1	33.	T-11906	277131	Electrode 70A MS/SS/AL	5
12.	T-11891	277153	Inner Retaining Cap 70A MS/SS/AL	1	34.	T-11902	277282-PRO	Electrode 100A MS/SS/AL, Silver PRO	5
13.	T-11908	277151	Inner Retaining Cap 100A MS/SS/AL	1	35.	T-11904	277292-PRO	Electrode 150A MS/SS/AL, Silver PRO	5
14.	T-11890	277152	Inner Retaining Cap 150A MS/SS/AL	1	36.	T-11903	277291-PRO	Electrode 200A MS/SS/AL, Silver PRO	5
15.	T-11889	277266	Inner Retaining Cap 200/275A MS/SS/AL	1	37.	T-11905	277270-PRO	Electrode 275A MS/SS/AL, Silver PRO	5
16.	T-12053	284156	Inner Retaining Cap 400A SS/AL	1	38.	T-12061	284159	Electrode 400A SS/AL	5
17.	T-12054	277121	Nozzle 30A SS	1	39.	T-11944	277007	Cooling Tube	1
18.	T-12055	277123	Nozzle 50A SS	1	40.	T-11322	12.40320	Wrench for Swirl Ring 150-400A	1
19.	T-11887	277125	Nozzle 70A MS/SS/AL	1	41.	Torches. See following pages for details.			
20.	T-11886	277284	Nozzle 100A MS/SS/AL, Air	1					
21.	T-11885	277293	Nozzle 150A MS/SS/AL, Air	1					
22.	T-11884	277289	Nozzle 200A MS/SS/AL, Air	1					

OD ON DEMAND – WE DO NOT KEEP THESE PARTS IN STOCK, COST IS SET ACCORDING TO THE ORDERED QUANTITY, DELIVERY TIME MAY DIFFER FROM STANDARD PRODUCTS.

***** FULLY INTERCHANGEABLE AND COMPATIBLE WITH ORIGINAL PARTS, BUT DIFFERS FROM ORIGINAL DESIGN

-PRO SILVER PRO TECHNOLOGY INCREASES ELECTRODE LIFETIME SIGNIFICANTLY COMPARED TO STANDARD COPPER ELECTRODES

THERMACUT®, FHT-EX® AND EX-TRAFIRE® ARE REGISTERED TRADEMARKS OF THERMACUT, K. S. AND MAY BE REGISTERED IN CZECH REPUBLIC AND/OR OTHER COUNTRIES. ALL OTHER TRADEMARKS ARE PROPERTIES OF THEIR RESPECTIVE OWNERS. THERMACUT IS NO WAY AFFILIATED WITH KALIBURN®. MOST THERMACUT PARTS ARE MADE FOR OR BY AN IBG COMPANY. PARTS INDICATED WITH A OEM ARE ORIGINAL PARTS MANUFACTURED BY THE ABOVE NAMED MANUFACTURER AND ARE BEING RESOLD BY THERMACUT. THERMACUT RESERVES THE RIGHT TO SUBSTITUTE OEM PARTS IN PLACE OF THERMACUT PARTS. VALID FROM SEPTEMBER 2024 • PREVIOUS VERSION IS NO LONGER VALID. • © COPYRIGHT 2024 BY THERMACUT® CZECH REPUBLIC. ALL RIGHTS RESERVED.

**THERMACUT® REPLACEMENT PARTS SUITABLE FOR
KALIBURN®**

SPIRIT®, ProLine™

SPIRIT® 150a, 200a, 275a, 400a, ProLine™ 2150, 2200, 2260 ALUMINIUM

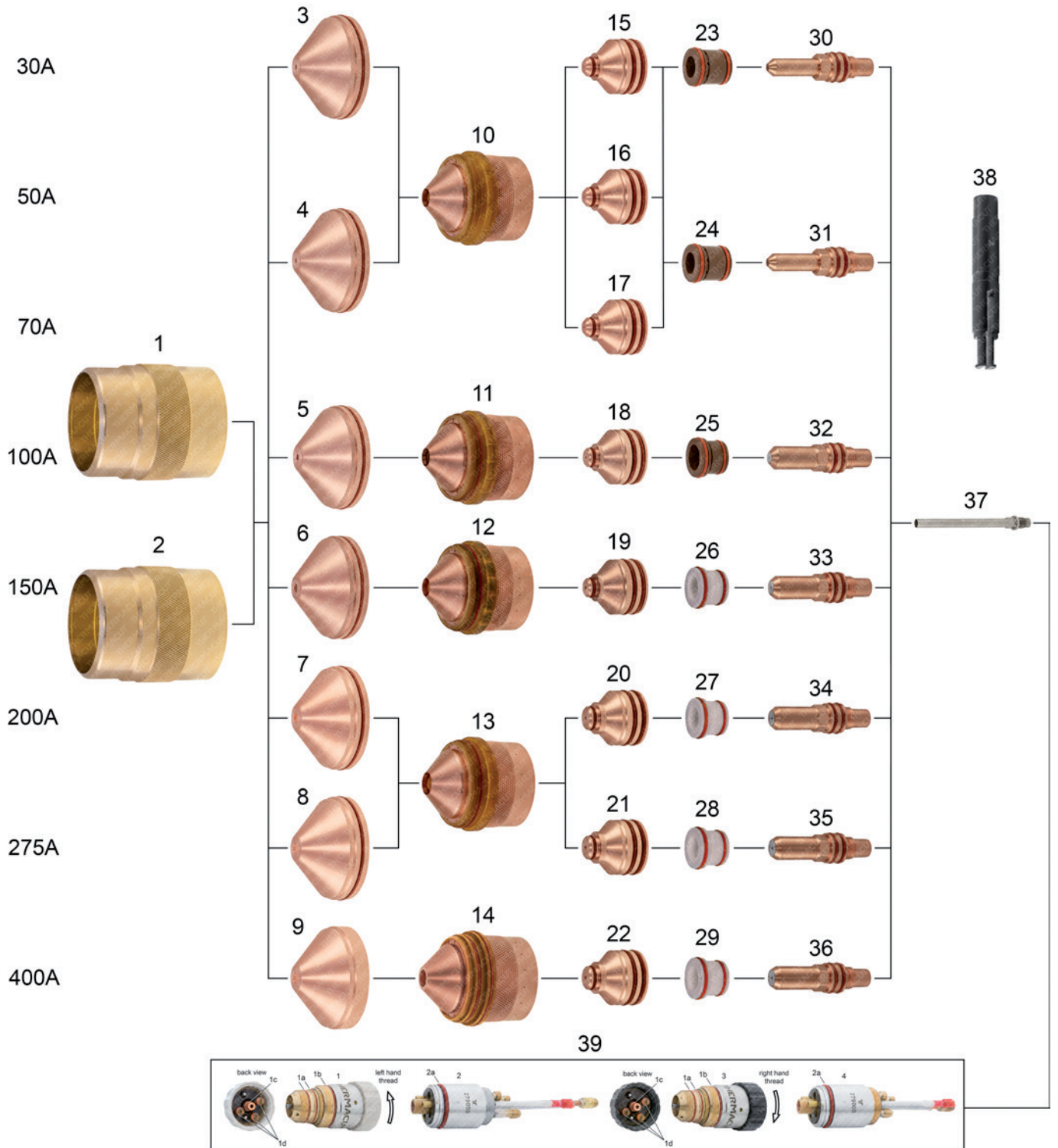

THERMACUT®, FHT-EX® AND EX-TRAFIRE® ARE REGISTERED TRADEMARKS OF THERMACUT, K. S. AND MAY BE REGISTERED IN CZECH REPUBLIC AND/OR OTHER COUNTRIES. ALL OTHER TRADEMARKS ARE PROPERTIES OF THEIR RESPECTIVE OWNERS. THERMACUT IS NO WAY AFFILIATED WITH KALIBURN®. MOST THERMACUT PARTS ARE MADE FOR OR BY AN IBG COMPANY. PARTS INDICATED WITH A OEM ARE ORIGINAL PARTS MANUFACTURED BY THE ABOVE NAMED MANUFACTURER AND ARE BEING RESOLD BY THERMACUT. THERMACUT RESERVES THE RIGHT TO SUBSTITUTE OEM PARTS IN PLACE OF THERMACUT PARTS. VALID FROM SEPTEMBER 2024 • PREVIOUS VERSION IS NO LONGER VALID. • © COPYRIGHT 2024 BY THERMACUT® CZECH REPUBLIC. ALL RIGHTS RESERVED.

THERMACUT® REPLACEMENT PARTS SUITABLE FOR KALIBURN®

SPIRIT®, ProLine™

SPIRIT® 150a, 200a, 275a, 400a, ProLine™ 2150, 2200, 2260 ALUMINIUM



PRODUCT BROCHURE WITH DETAILS AT
WWW.THERMACUT.COM

Item	Part No.	Ref. No.	Description	Std. Pkg.	Item	Part No.	Ref. No.	Description	Std. Pkg.
1.	T-11909	284150	Outer Retaining Cap 30-400A	1	21.	T-12056	277276	Nozzle 275A SS/AL	1
2.	T-11892	277154	Outer Retaining Cap 30-275A	1	22.	T-12058	284158	Nozzle 400A AL	1
3.	T-12034	277145	Shield Cap 30A MS/AL	1	23.	T-12033	277140	Swirl Ring 30A MS/SS/AL, H17	1
4.	T-11901	277150	Shield Cap 50/70A MS/SS/AL	1	24.	T-11894	277142	Swirl Ring 50/70A MS/SS/AL	1
5.	T-11898	277286	Shield Cap 100A MS/SS/AL, Air	1	25.	T-11893	277283	Swirl Ring 100A MS/SS/AL	1
6.	T-11907	277117	Shield Cap 150A MS/SS/AL	1	*26.	T-11897	277139-UR	Swirl Ring 150A MS/SS/AL	1
7.	T-11899	277274	Shield Cap 200A MS/SS/AL	1	*27.	T-11896	277143-UR	Swirl Ring 200A MS/SS/AL	1
8.	T-11900	277263	Shield Cap 275A MS/SS/AL	1	*28.	T-11895	277258-UR	Swirl Ring 275A MS/SS/AL	1
9.	T-12051	284155	Shield Cap 400A SS/AL	1	*29.	T-12036	284122-UR	Swirl Ring 400A MS/SS/AL	1
10.	T-11891	277153	Inner Retaining Cap 30-70A MS/SS/AL	1	30.	T-12032	277130	Electrode 30A MS/AL	1
11.	T-11908	277151	Inner Retaining Cap 100A MS/SS/AL	1	31.	T-11906	277131	Electrode 50/70A MS/SS/AL	5
12.	T-11890	277152	Inner Retaining Cap 150A MS/SS/AL	1	32.	T-11902	277282-PRO	Electrode 100A MS/SS/AL, Silver PRO	5
13.	T-11889	277266	Inner Retaining Cap 200/275A MS/SS/AL	1	33.	T-11904	277292-PRO	Electrode 150A MS/SS/AL, Silver PRO	5
14.	T-12053	284156	Inner Retaining Cap 400A SS/AL	1	34.	T-11903	277291-PRO	Electrode 200A MS/SS/AL, Silver PRO	5
15.	T-12030	277120	Nozzle 30A MS/AL	1	35.	T-11905	277270-PRO	Electrode 275A MS/SS/AL, Silver PRO	5
16.	T-12031	277122	Nozzle 50A MS/AL	1	36.	T-12061	284159	Electrode 400A SS/AL	5
17.	T-11887	277125	Nozzle 70A MS/SS/AL	1	37.	T-11944	277007	Cooling Tube	1
18.	T-11886	277284	Nozzle 100A MS/SS/AL, Air	1	38.	T-11322	12.40320	Wrench for Swirl Ring 150-400A	1
19.	T-11885	277293	Nozzle 150A MS/SS/AL, Air	1	39.	Torches. See following pages for details.			
20.	T-11884	277289	Nozzle 200A MS/SS/AL, Air	1					

* FULLY INTERCHANGEABLE AND COMPATIBLE WITH ORIGINAL PARTS, BUT DIFFERS FROM ORIGINAL DESIGN

-PRO SILVER PRO TECHNOLOGY INCREASES ELECTRODE LIFETIME SIGNIFICANTLY COMPARED TO STANDARD COPPER ELECTRODES

THERMACUT®, FHT-EX® AND EX-TRAFIRE® ARE REGISTERED TRADEMARKS OF THERMACUT, K. S. AND MAY BE REGISTERED IN CZECH REPUBLIC AND/OR OTHER COUNTRIES. ALL OTHER TRADEMARKS ARE PROPERTIES OF THEIR RESPECTIVE OWNERS. THERMACUT IS NO WAY AFFILIATED WITH KALIBURN®. MOST THERMACUT PARTS ARE MADE FOR OR BY AN IBG COMPANY. PARTS INDICATED WITH A OEM ARE ORIGINAL PARTS MANUFACTURED BY THE ABOVE NAMED MANUFACTURER AND ARE BEING RESOLD BY THERMACUT. THERMACUT RESERVES THE RIGHT TO SUBSTITUTE OEM PARTS IN PLACE OF THERMACUT PARTS. VALID FROM SEPTEMBER 2024 • PREVIOUS VERSION IS NO LONGER VALID. • © COPYRIGHT 2024 BY THERMACUT® CZECH REPUBLIC. ALL RIGHTS RESERVED.

**THERMACUT® REPLACEMENT PARTS SUITABLE FOR
KALIBURN®
SPIRIT®, ProLine™ | TORCHES**

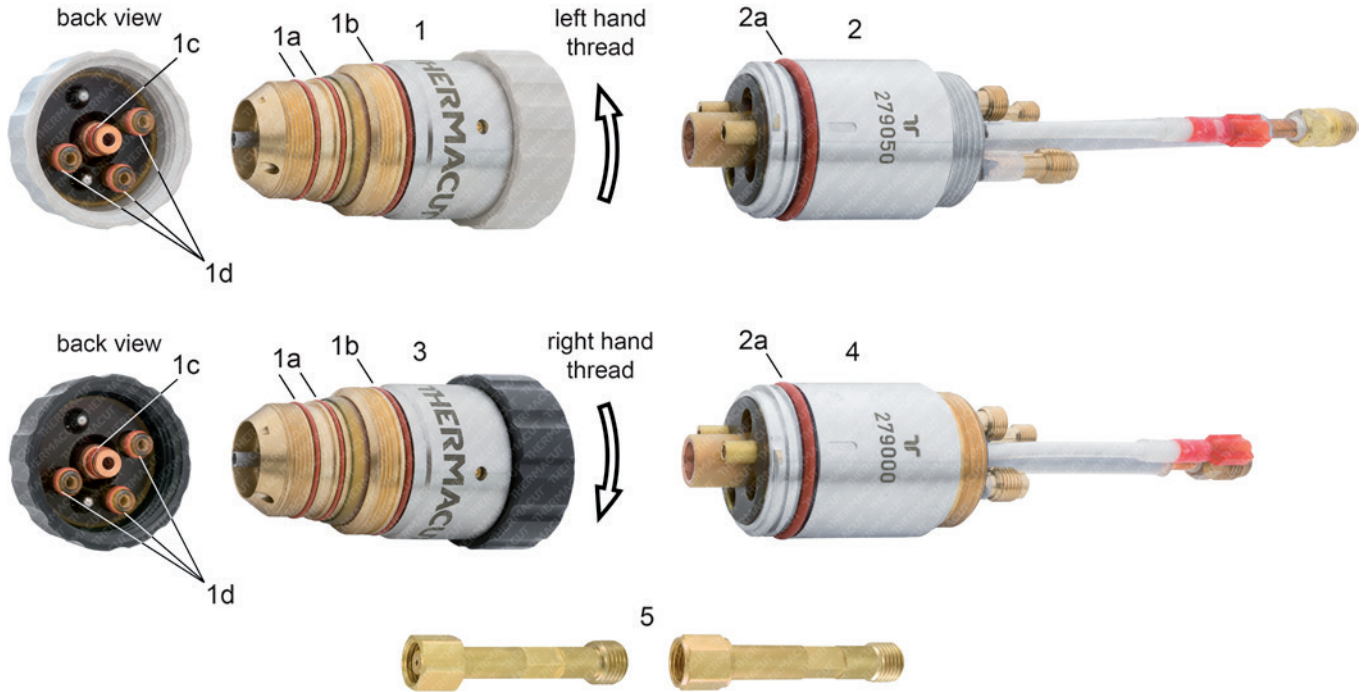

Item	Part No.	Ref. No.	Description	Std. Pkg.	Item	Part No.	Ref. No.	Description	Std. Pkg.
1.	T-12182	279150	Torch Body, Spirit 150-275A	1	2a.	N-21421	N-21421	O-Ring	10
1a.	N-10092	N-10092	2× O-Ring	1	3.	T-13082	279100	Torch Body, Spirit 400A	1
1b.	N-21467	N-21467	O-Ring	1	4.	T-13083	279000	Torch Base, Spirit 400A	1
1c.	N-21415	N-21415	O-Ring	1	5.	T-13195	T-13195	Adaptor Kit to upgrade 1-piece Torch 277000 to 2-piece Torch Adaptor 279050	1
1d.	N-10055	N-10055	6× O-Ring	1					
2.	T-12185	279050	Torch Base, Spirit 150-275A	1					

NS NOT SHOWN IN THE PICTURE

THERMACUT®, FHT-EX® AND EX-TRAFIRE® ARE REGISTERED TRADEMARKS OF THERMACUT, K. S. AND MAY BE REGISTERED IN CZECH REPUBLIC AND/OR OTHER COUNTRIES. ALL OTHER TRADEMARKS ARE PROPERTIES OF THEIR RESPECTIVE OWNERS. THERMACUT IS NO WAY AFFILIATED WITH KALIBURN®. MOST THERMACUT PARTS ARE MADE FOR OR BY AN IBG COMPANY. PARTS INDICATED WITH A OEM ARE ORIGINAL PARTS MANUFACTURED BY THE ABOVE NAMED MANUFACTURER AND ARE BEING RESOLD BY THERMACUT. THERMACUT RESERVES THE RIGHT TO SUBSTITUTE OEM PARTS IN PLACE OF THERMACUT PARTS. VALID FROM SEPTEMBER 2024 • PREVIOUS VERSION IS NO LONGER VALID. • © COPYRIGHT 2024 BY THERMACUT® CZECH REPUBLIC. ALL RIGHTS RESERVED.

- This page intentionally left blank -

**THERMACUT® REPLACEMENT PARTS SUITABLE FOR
KJELLBERG®
PA-S20W™, PA-S25W™, PA-S40W™, PA-S45W™, PA-S70W™ | PB-S45W™**

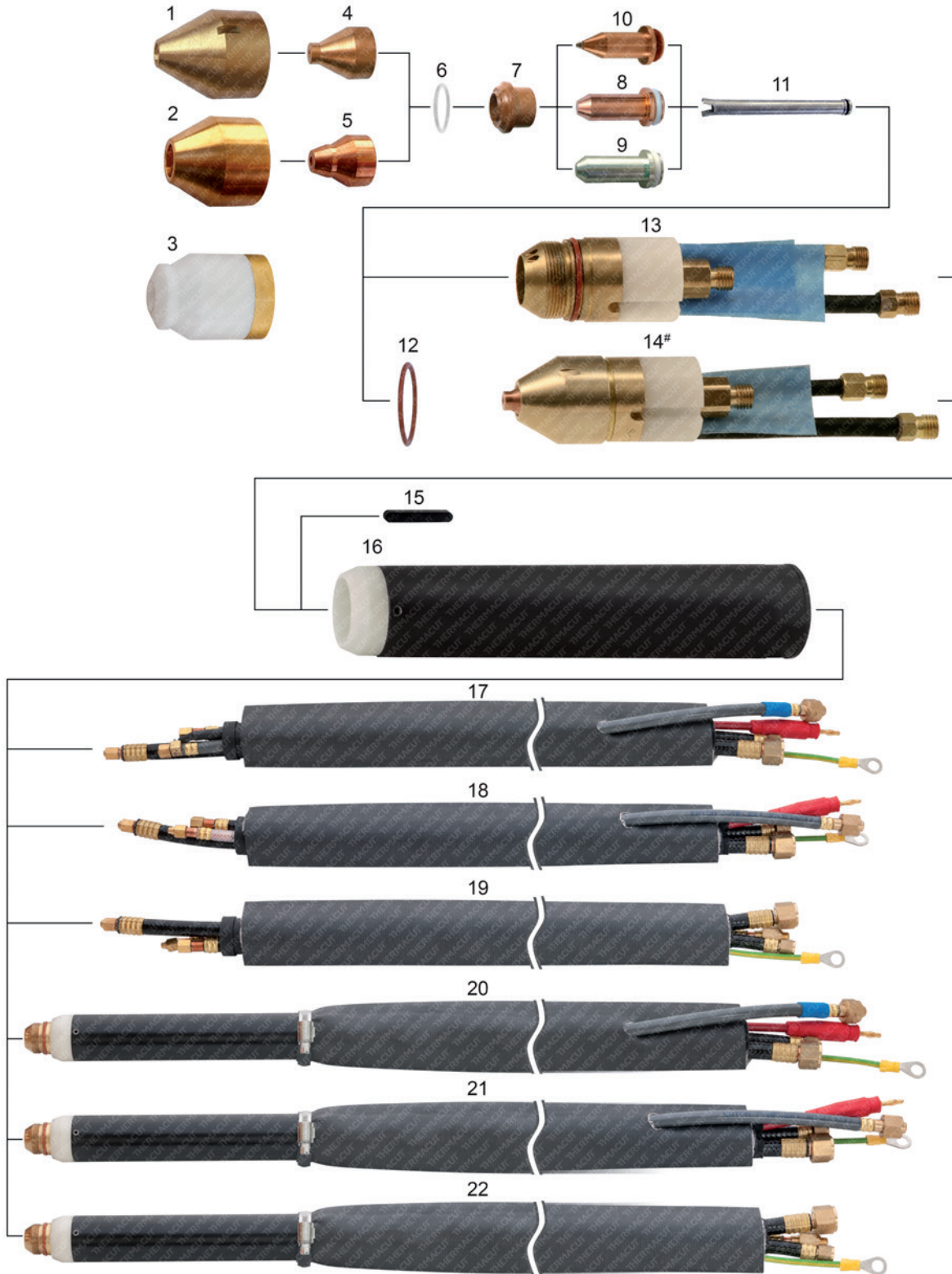

THERMACUT®, FHT-EX® AND EX-TRAFIRE® ARE REGISTERED TRADEMARKS OF THERMACUT, K. S. AND MAY BE REGISTERED IN CZECH REPUBLIC AND/OR OTHER COUNTRIES. ALL OTHER TRADEMARKS ARE PROPERTIES OF THEIR RESPECTIVE OWNERS. THERMACUT IS NO WAY AFFILIATED WITH KJELLBERG®. MOST THERMACUT PARTS ARE MADE FOR OR BY AN IBG COMPANY. PARTS INDICATED WITH A OEM ARE ORIGINAL PARTS MANUFACTURED BY THE ABOVE NAMED MANUFACTURER AND ARE BEING RESOLD BY THERMACUT. THERMACUT RESERVES THE RIGHT TO SUBSTITUTE OEM PARTS IN PLACE OF THERMACUT PARTS. VALID FROM SEPTEMBER 2024 • PREVIOUS VERSION IS NO LONGER VALID. • © COPYRIGHT 2024 BY THERMACUT® CZECH REPUBLIC. ALL RIGHTS RESERVED.

THERMACUT® REPLACEMENT PARTS SUITABLE FOR KJELLBERG®

PA-S20W™, PA-S25W™, PA-S40W™, PA-S45W™, PA-S70W™ | PB-S45W™

Item	Part No.	Ref. No.	Sh.Ref.No.	Description	Std.Pkg.	Item	Part No.	Ref. No.	Sh.Ref.No.	Description	Std.Pkg.
1.	T-8609	11.828.201.151		Nose Cap 6.0	1	15.	PT-12482	11.828.201.250-3		Tube Pin	1
2.	T-8617	11.830.301.151		Nose Cap 9.6	1	16.	T-8610	11.828.201.250		Tube Complete, incl. pos. 15	1
3.	T-10040	11.828.101.160		Protection Cap, Hand	1	17.	KT-1068	11.832.521.701		Cable Leads 10m PB-S45W-1/O ₂	1
4.	T-8612	11.828.201.413	Ld	Nozzle 1.3mm 90A, Air	5		KT-1449	K.PB-S45W-102.15M.K		Cable Leads 15m PB-S45W-1/O ₂	1
5.	T-8614	11.828.203.410	Lle	Nozzle 1.0mm 45A, Lle, Air	10	18.	T-13237	11.832.501.700		Cable Leads 6m PB-S45W-1/L	1
	T-8615	11.828.203.413	Lde	Nozzle 1.3mm 90A, Lde, Air	10		KT-1468	11.832.501.701		Cable Leads 10m PB-S45W-1/L	1
	T-8616	11.828.203.414	Lee	Nozzle 1.4mm 130A, Lee, Air	10		KT-1373	K.PB-S45W-1L15M.K		Cable Leads 15m PB-S45W-1/L	1
OD	T-8736	11.828.213.613	Ade	Nozzle 1.3mm 80A, ArH2	10		KT-1516	K.PB-S45W-1L17M.K		Cable Leads 18m PB-S45W-1/L	1
OD	T-8737	11.828.213.614	Aee	Nozzle 1.4mm 100A, ArH2	5	19.	KT-1473	11.831.601.700		Cable Leads 6m PB-S45WH/L	1
	T-8738	11.828.213.616	Afe	Nozzle 1.6mm 130A, ArH2	5		KT-1296	11.832.401.701		Cable Leads 10m PB-S45W/L	1
	T-8620	11.834.321.410	Lle-XL	Nozzle 1.0mm 45A, O ₂	10		KT-1322	K.PB-S45W-L.15M.K		Cable Leads 15m PB-S45W/L	1
	T-8621	11.834.321.413	Lde-XL	Nozzle 1.3mm 90A, O ₂	10	20.	KT-1208	11.832.521.006		Torch with Leads 6m PB-S45W-1/O ₂	1
	T-8622	11.834.321.414	Lee-XL	Nozzle 1.4mm 130A, O ₂	10		KT-1255	11.832.521.010		Torch with Leads 10m PB-S45W-1/O ₂	1
6.	T-8601	10.575.036		O-Ring	10		KT-1490	K.PB-S45W-1L-O2.15M		Torch with Leads 15m PB-S45W-1/O ₂	1
7.	T-8604	11.828.001.153	Z111	Swirl Ring	1	21.	KT-1230	11.832.501.1015		Torch with Leads 1.5m PB-S45W-1/L	1
OD	T-10794	11.828.001.153K	Z111	Swirl Ring, Ceramic	5		KT-1413	11.832.501.006		Torch with Leads 6m PB-S45W-1/L	1
8.	T-8605	11.828.001.3001	Kb	Cathode	5		KT-1254	11.832.501.010		Torch with Leads 10m PB-S45W-1/L	1
9.	T-4921	11.834.321.3001-AG		Cathode, SilverEX-®	5	OD	KT-1272	K.PB-S45W-1L15M		Torch with Leads 15m PB-S45W-1/L	1
10.	T-8735	11.828.211.5001	Ka	Cathode, ArH2 (i)	5	22.	KT-1402	11.832.401.006		Torch with Leads 6m PB-S45W/L	1
11.	T-8603	11.828.001.152		Cooling Tube	1		KT-1116	11.832.401.010		Torch with Leads 10m PB-S45W/L	1
12.	T-8602	10.575.052		O-Ring	10		KT-1054	K.PB-S45W-L.15M		Torch with Leads 15m PB-S45W/L	1
13.	T-8926	11.828.301.100		Torch Body, Machine	1		KT-1356	K.PB-S45W-L.20M		Torch with Leads 20m PB-S45W/L	1
#14.	T-8607#	11.828.201.100		Complete Torch, Machine	1	NS	KT-1417	K.PB-S45W-1L-O2.20M		Torch with Leads 20m PB-S45W/L-1/O ₂	1
OD NS	T-11572	11.828.001.810 OEM		Nose Cap Tool	1					Different types of cable leads available on request	

OD ON DEMAND – WE DO NOT KEEP THESE PARTS IN STOCK, COST IS SET ACCORDING TO THE ORDERED QUANTITY, DELIVERY TIME MAY DIFFER FROM STANDARD PRODUCTS.

(i) THIS PART MAY NOT BE DISTRIBUTED ON THE GERMAN MARKET. THERMACUT® ACCEPTS NO RESPONSIBILITY IN CASE OF INDIRECT SALES TO GERMANY.

INCLUDING PARTS: TORCH 11.828.301.100, ELECTRODE 11.828.001.3001, SWIRL RING 11.828.001.153, O-RING 10.575.036, NOZZLE 11.828.203.413, NOSE CAP 11.830.301.151

NS NOT SHOWN IN THE PICTURE

THERMACUT®, FHT-EX® AND EX-TRAFIRE® ARE REGISTERED TRADEMARKS OF THERMACUT, K. S. AND MAY BE REGISTERED IN CZECH REPUBLIC AND/OR OTHER COUNTRIES. ALL OTHER TRADEMARKS ARE PROPERTIES OF THEIR RESPECTIVE OWNERS. THERMACUT IS NO WAY AFFILIATED WITH KJELLBERG®.

MOST THERMACUT PARTS ARE MADE FOR OR BY AN IBG COMPANY. PARTS INDICATED WITH A OEM ARE ORIGINAL PARTS MANUFACTURED BY THE ABOVE NAMED MANUFACTURER AND ARE BEING RESOLD BY THERMACUT. THERMACUT RESERVES THE RIGHT TO SUBSTITUTE OEM PARTS IN PLACE OF THERMACUT PARTS.

VALID FROM SEPTEMBER 2024 • PREVIOUS VERSION IS NO LONGER VALID. • © COPYRIGHT 2024 BY THERMACUT® CZECH REPUBLIC. ALL RIGHTS RESERVED.

**THERMACUT® REPLACEMENT PARTS SUITABLE FOR
KJELLBERG®
FineFocus® 450 | PB-S47™ W - 1 / O₂**

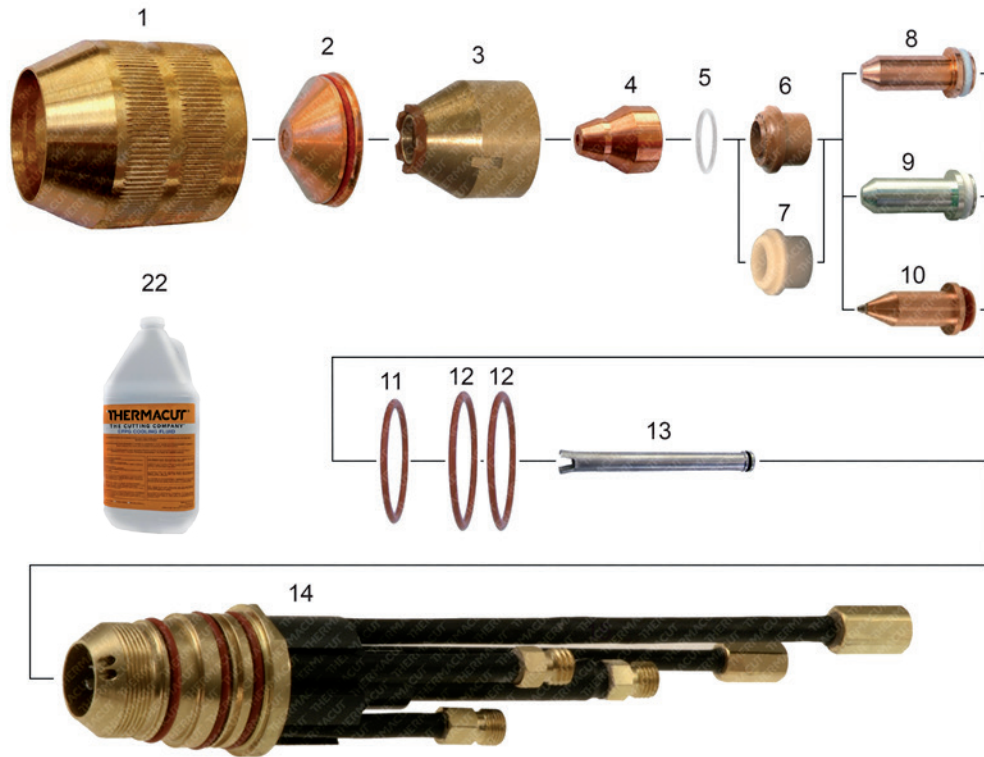

1:3



THERMACUT®, FHT-EX® AND EX-TRAFIRE® ARE REGISTERED TRADEMARKS OF THERMACUT, K. S. AND MAY BE REGISTERED IN CZECH REPUBLIC AND/OR OTHER COUNTRIES. ALL OTHER TRADEMARKS ARE PROPERTIES OF THEIR RESPECTIVE OWNERS. THERMACUT IS NO WAY AFFILIATED WITH KJELLBERG®. MOST THERMACUT PARTS ARE MADE FOR OR BY AN IBG COMPANY. PARTS INDICATED WITH A OEM ARE ORIGINAL PARTS MANUFACTURED BY THE ABOVE NAMED MANUFACTURER AND ARE BEING RESOLD BY THERMACUT. THERMACUT RESERVES THE RIGHT TO SUBSTITUTE OEM PARTS IN PLACE OF THERMACUT PARTS. VALID FROM SEPTEMBER 2024 • PREVIOUS VERSION IS NO LONGER VALID. • © COPYRIGHT 2024 BY THERMACUT® CZECH REPUBLIC. ALL RIGHTS RESERVED.

**THERMACUT® REPLACEMENT PARTS SUITABLE FOR
KJELLBERG®
FineFocus® 450 | PB-S47™ W - 1 / O₂**

Item	Part No.	Ref. No.	Sh.Ref.No.	Description	Std.Pkg.	Item	Part No.	Ref. No.	Sh.Ref.No.	Description	Std.Pkg.
1.	T-8641	11.832.201.081	W501	Protection Cap	1	10.	T-8735	11.828.211.5001	Ka	Cathode, ArH2 (i)	5
2.	T-8642	11.832.201.1561	W4130	Swirl Gas Cup 3.0	10	11.	T-8602	10.575.052		O-Ring	10
	T-8643	11.832.201.1571	W4140	Swirl Gas Cup 4.0	10	12.	T-8647	10.505.915		O-Ring	1
3.	T-8644	11.832.201.160	W3030	Nozzle Cap	1	13.	PT-10232	11.832.201.152	W901	Cooling Tube	1
4.	T-8614	11.828.203.410	Lle	Nozzle 1.0mm 45A, Lle, Air	10	14.	T-8649	11.832.221.100		Torch Body, Machine	1
	T-8615	11.828.203.413	Lde	Nozzle 1.3mm 90A, Lde, Air	10	OD 15.	T-8648	10.505.948		O-Ring	10
	T-8616	11.828.203.414	Lee	Nozzle 1.4mm 130A, Lee, Air	10	OD 16.	T-10193	11.832.221.100-10		Tube Adaptor	1
	T-8620	11.834.321.410	Lle-XL	Nozzle 1.0mm 45A, O ₂	10	17.	T-10925	11.832.201.077		Clamping Bush	1
	T-8621	11.834.321.413	Lde-XL	Nozzle 1.3mm 90A, O ₂	10	18.	T-10924	11.832.201.076		Outer Bush	1
	T-8622	11.834.321.414	Lee-XL	Nozzle 1.4mm 130A, O ₂	10	19.	T-10772	11.834.321.250		Tube PB-S47W™	1
OD	T-8736	11.828.213.613	Ade	Nozzle 1.3mm 80A, ArH2	10	20.	KT-1155	11.834.721.1015		Torch with Leads 1.5m 2/O ₂	1
OD	T-8737	11.828.213.614	Aee	Nozzle 1.4mm 100A, ArH2	5	21.	KT-1056	11.834.321.006		Torch with Leads 6m 1/O ₂	1
	T-8738	11.828.213.616	Afe	Nozzle 1.6mm 130A, ArH2	5		KT-1422	11.834.321.010		Torch with Leads 10m 1/O ₂	1
5.	T-8601	10.575.036		O-Ring	10		KT-1102	11.834.321.015		Torch with Leads 15m 1/O ₂	1
6.	T-8618	11.834.321.153	Z111	Swirl Ring	1		KT-1127	K.PB-S47W.20M		Torch with Leads 20m 1/O ₂	1
7.	T-9287	11.834.321.153K	Z111	Swirl Ring, Ceramic	1	NS	KT-1470	11.834.321.701A		PB-S47W™ Cable Leads 15m 1/O ₂	1
8.	T-8619	11.834.321.3001	Kb-XL	Cathode	5	NS	T-13187	11.834.721.700B		PB-S47W™ Cable Leads 1.5m 2/O ₂	1
9.	T-4921	11.834.321.3001-AG	Kb-XL	Cathode, SilverEX-®	5	22.	Coolant Liquid. Details on the Accessories page.				

OD ON DEMAND – WE DO NOT KEEP THESE PARTS IN STOCK, COST IS SET ACCORDING TO THE ORDERED QUANTITY, DELIVERY TIME MAY DIFFER FROM STANDARD PRODUCTS.

(i) THIS PART MAY NOT BE DISTRIBUTED ON THE GERMAN MARKET. THERMACUT® ACCEPTS NO RESPONSIBILITY IN CASE OF INDIRECT SALES TO GERMANY.

NS NOT SHOWN IN THE PICTURE

THERMACUT®, FHT-EX® AND EX-TRAFIRE® ARE REGISTERED TRADEMARKS OF THERMACUT, K. S. AND MAY BE REGISTERED IN CZECH REPUBLIC AND/OR OTHER COUNTRIES. ALL OTHER TRADEMARKS ARE PROPERTIES OF THEIR RESPECTIVE OWNERS. THERMACUT IS NO WAY AFFILIATED WITH KJELLBERG®. MOST THERMACUT PARTS ARE MADE FOR OR BY AN IBG COMPANY. PARTS INDICATED WITH A OEM ARE ORIGINAL PARTS MANUFACTURED BY THE ABOVE NAMED MANUFACTURER AND ARE BEING RESOLD BY THERMACUT. THERMACUT RESERVES THE RIGHT TO SUBSTITUTE OEM PARTS IN PLACE OF THERMACUT PARTS.
VALID FROM SEPTEMBER 2024 • PREVIOUS VERSION IS NO LONGER VALID. • © COPYRIGHT 2024 BY THERMACUT® CZECH REPUBLIC. ALL RIGHTS RESERVED.

**THERMACUT® REPLACEMENT PARTS SUITABLE FOR
KJELLBERG®
HiFocus® 100 | PerCut® 100, PerCut® 101**

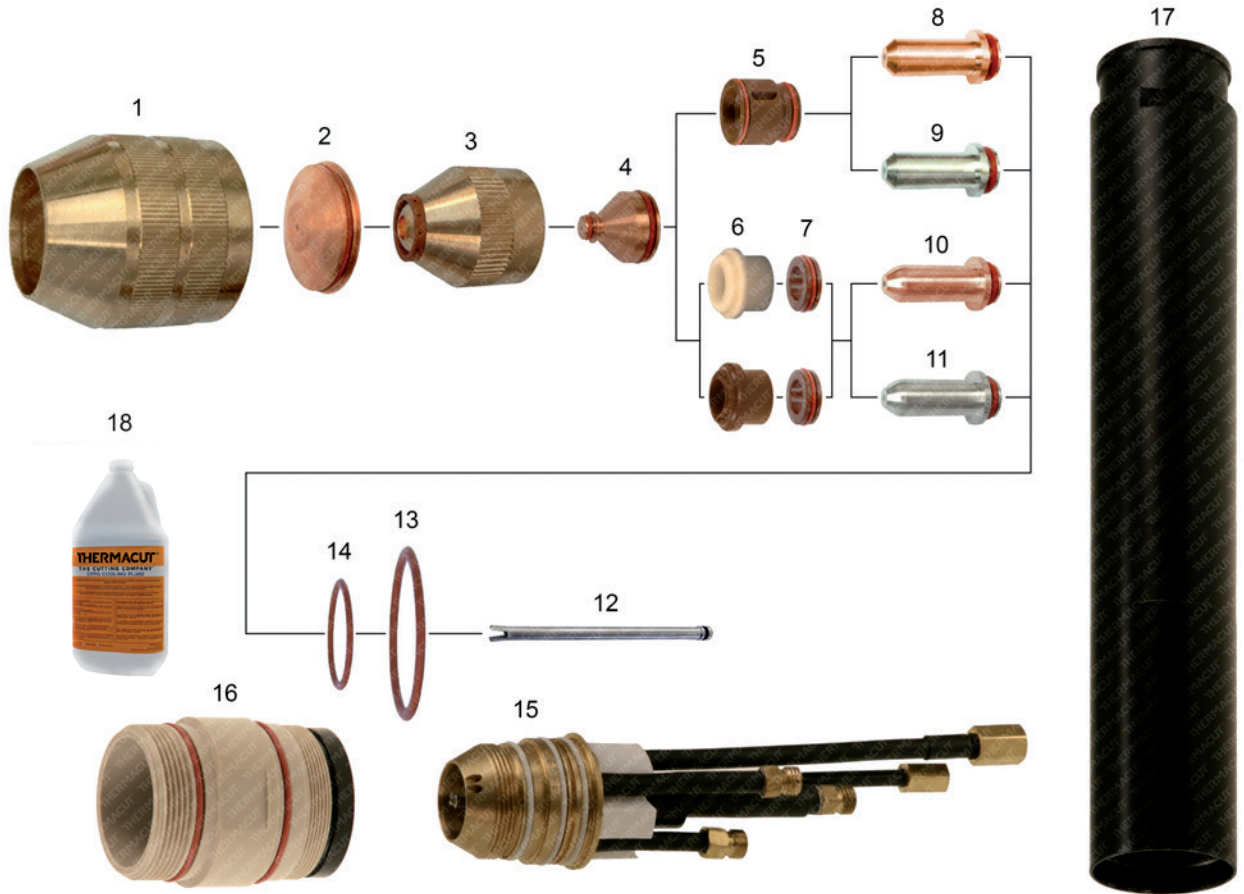

THERMACUT®, FHT-EX® AND EX-TRAFIRE® ARE REGISTERED TRADEMARKS OF THERMACUT, K. S. AND MAY BE REGISTERED IN CZECH REPUBLIC AND/OR OTHER COUNTRIES. ALL OTHER TRADEMARKS ARE PROPERTIES OF THEIR RESPECTIVE OWNERS. THERMACUT IS NO WAY AFFILIATED WITH KJELLBERG®. MOST THERMACUT PARTS ARE MADE FOR OR BY AN IBG COMPANY. PARTS INDICATED WITH A OEM ARE ORIGINAL PARTS MANUFACTURED BY THE ABOVE NAMED MANUFACTURER AND ARE BEING RESOLD BY THERMACUT. THERMACUT RESERVES THE RIGHT TO SUBSTITUTE OEM PARTS IN PLACE OF THERMACUT PARTS. VALID FROM SEPTEMBER 2024 • PREVIOUS VERSION IS NO LONGER VALID. • © COPYRIGHT 2024 BY THERMACUT® CZECH REPUBLIC. ALL RIGHTS RESERVED.

THERMACUT® REPLACEMENT PARTS SUITABLE FOR KJELLBERG®

HiFocus® 100 | PerCut® 100, PerCut® 101

Item	Part No.	Ref. No.	Sh.Ref.No.	Description	Std. Pkg.	Item	Part No.	Ref. No.	Sh.Ref.No.	Description	Std. Pkg.	
1.	T-8630	11.835.201.081	Z501	Protection Cap	1	7.	T-8655	11.835.421.303	Z111A	Spacer	2	
2.	T-8631	11.835.201.1561	Z4015	Swirl Gas Cap 1.5	10	8.	T-8624	11.835.221.3101	Z002Cu	Cathode, XL, O ₂ , Copper (i)	5	
	T-8632	11.835.201.1571	Z4020	Swirl Gas Cap 2.0	10	9.	T-4922	11.835.221.3101-AG	Z002	Cathode, XL, O ₂ , SilverEX-®	5	
	T-8633	11.835.201.1581	Z4025	Swirl Gas Cap 2.5	10	10.	T-8653	11.835.421.3101-PRO	Z012Cu	Cathode, XL, O ₂ , Silver PRO	5	
	T-8634	11.835.201.1591	Z4030	Swirl Gas Cap 3.0	10	11.	T-4923	11.835.421.3101-AG	Z012	Cathode, XL, O ₂ , SilverEX-®	5	
	T-8650	11.835.401.1571	Z4140	Swirl Gas Cap 4.0	10	12.	T-8638	11.835.201.152	Z901	Cooling Tube	1	
	T-9928	11.835.411.1581	Z4530	Swirl Gas Cap 3.0	10	13.	T-8640	10.505.946		O-Ring	10	
3.	T-9929	11.835.411.1591	Z4540	Swirl Gas Cap 4.0	10	OD14.	N-10040	10.505.916		O-Ring	1	
	T-10154	11.835.411.1590	Z4545	Swirl Gas Cap 4.5	10	15.	T-8654	11.835.221.100		Torch Body, Machine	1	
	T-8635	11.835.201.160	Z3004	Nozzle Cap 0.4	1	16.	T-10282	11.842.221.100-10		Tube Adaptor	1	
	T-8636	11.835.201.162	Z3008	Nozzle Cap 0.8	1	17.	T-9857	11.842.421.250		Tube D44-295	1	
	T-8625	11.835.221.406	Z2006	Nozzle 0.6 25A	5	NS	T-9755	11.835.201.077		Clamping Bush	1	
4.	T-8626	11.835.221.407	Z2007	Nozzle 0.7 35A	10	NS	T-9756	11.835.201.076		Outer Bush	1	
	T-8627	11.835.221.408	Z2008	Nozzle 0.8 50/60A	10	NS	KT-1203	11.838.221.1015		PerCut® 101-2	1	
	T-8628	11.835.221.410	Z2010	Nozzle 1.0 80/90A	10					Torch with Leads		
	T-8929	11.835.221.411	Z2011	Nozzle 1.1 90/100A	10	NS	KT-1185	11.838.421.700		PerCut® 101-1	1	
	T-8629	11.835.221.412	Z2012	Nozzle 1.2 100A	10					Cable Leads 6m		
	OD	T-8637	11.835.221.414	Z2014	Nozzle 1.4 130A					10		NS
	T-8651	11.835.421.412	Z2112	Nozzle 1.2 100A	10	Cable Leads 15m						
	5.	T-8652	11.835.421.414	Z2114	Nozzle 1.4 130A	10	NS	KT-1410	11.838.221.103		PerCut® 101-2	1
T-8623		11.835.221.153	Z101	Swirl Ring 0.4 (3×CW)	1	Torch with Leads						
6.	T-8886	11.835.221.154	Z102	Swirl Ring 0.4 (2×CW)	1	18.					Coolant Liquid. Details on the Accessories page.	
	T-9287	11.834.321.153K	Z111	Swirl Ring, Ceramic	1							
	T-8618	11.834.321.153	Z111	Swirl Ring, Vespel®	1							

OD ON DEMAND – WE DO NOT KEEP THESE PARTS IN STOCK, COST IS SET ACCORDING TO THE ORDERED QUANTITY, DELIVERY TIME MAY DIFFER FROM STANDARD PRODUCTS.

(i) THIS PART MAY NOT BE DISTRIBUTED ON THE GERMAN, ITALIAN, FRENCH AND GREAT BRITAIN MARKET. THERMACUT® ACCEPTS NO RESPONSIBILITY IN CASE OF INDIRECT SALES TO GERMANY, ITALY, FRANCE AND GREAT BRITAIN.

NS NOT SHOWN IN THE PICTURE

-PRO TECHNOLOGY OF SILVER INSERTED COPPER ELECTRODE BODY, WHICH SIGNIFICANTLY DECREASES ELECTRODE COSTS WITH SIMILAR WORK PERFORMANCE COMPARED TO FULL SILVER ELECTRODES.

THERMACUT®, FHT-EX® AND EX-TRAFIRE® ARE REGISTERED TRADEMARKS OF THERMACUT, K. S. AND MAY BE REGISTERED IN CZECH REPUBLIC AND/OR OTHER COUNTRIES. ALL OTHER TRADEMARKS ARE PROPERTIES OF THEIR RESPECTIVE OWNERS. THERMACUT IS NO WAY AFFILIATED WITH KJELLBERG®.

MOST THERMACUT PARTS ARE MADE FOR OR BY AN IBG COMPANY. PARTS INDICATED WITH A OEM ARE ORIGINAL PARTS MANUFACTURED BY THE ABOVE NAMED MANUFACTURER AND ARE BEING RESOLD BY THERMACUT. THERMACUT RESERVES THE RIGHT TO SUBSTITUTE OEM PARTS IN PLACE OF THERMACUT PARTS.

VALID FROM SEPTEMBER 2024 • PREVIOUS VERSION IS NO LONGER VALID. • © COPYRIGHT 2024 BY THERMACUT® CZECH REPUBLIC. ALL RIGHTS RESERVED.

**THERMACUT® REPLACEMENT PARTS SUITABLE FOR
KJELLBERG®
HiFocus® 160i | PerCut® 160 / PerCut® 170**

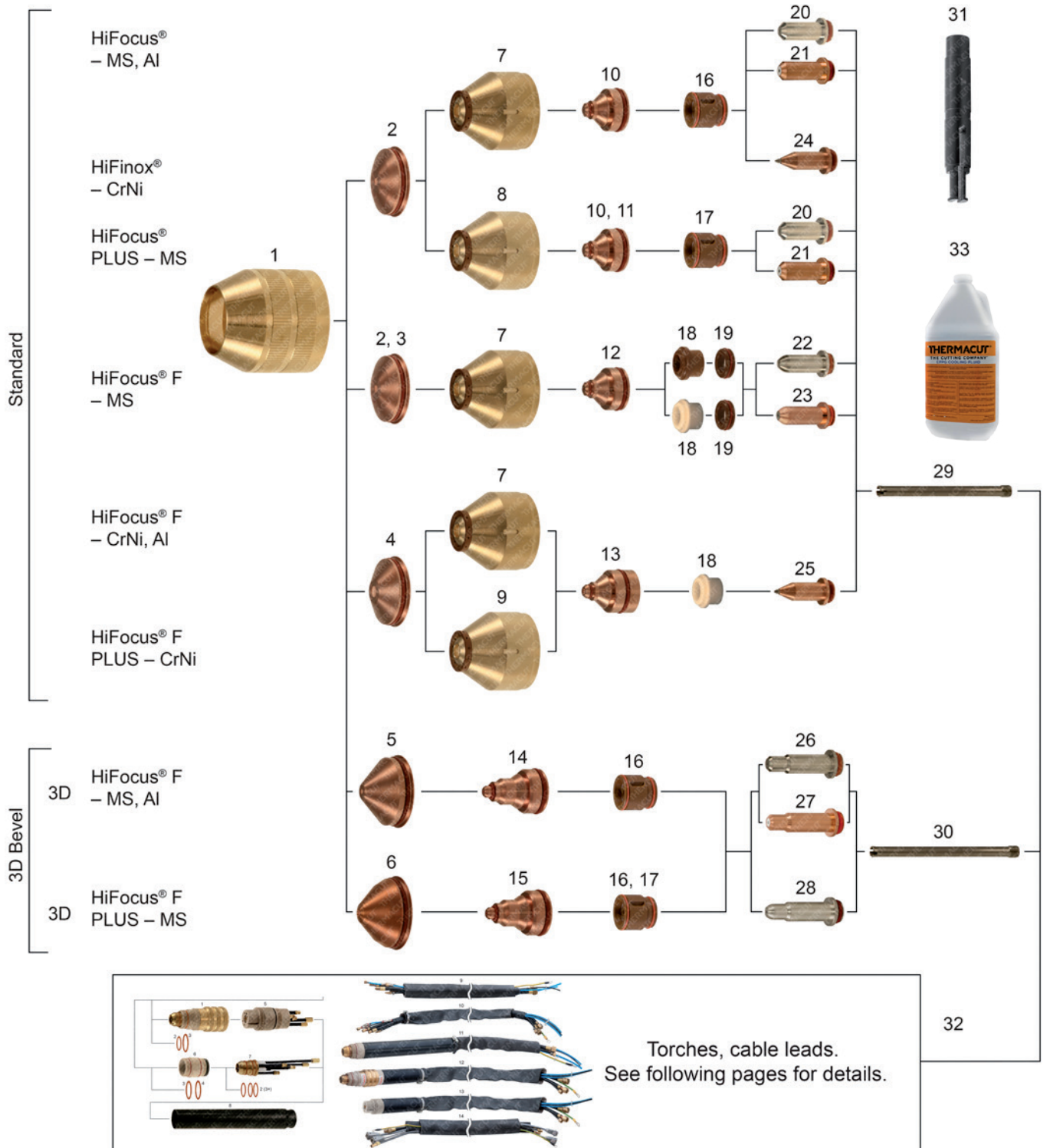

THERMACUT®, FHT-EX® AND EX-TRAFIRE® ARE REGISTERED TRADEMARKS OF THERMACUT, K. S. AND MAY BE REGISTERED IN CZECH REPUBLIC AND/OR OTHER COUNTRIES. ALL OTHER TRADEMARKS ARE PROPERTIES OF THEIR RESPECTIVE OWNERS. THERMACUT IS NO WAY AFFILIATED WITH KJELLBERG®. MOST THERMACUT PARTS ARE MADE FOR OR BY AN IBG COMPANY. PARTS INDICATED WITH A OEM ARE ORIGINAL PARTS MANUFACTURED BY THE ABOVE NAMED MANUFACTURER AND ARE BEING RESOLD BY THERMACUT. THERMACUT RESERVES THE RIGHT TO SUBSTITUTE OEM PARTS IN PLACE OF THERMACUT PARTS. VALID FROM SEPTEMBER 2024 • PREVIOUS VERSION IS NO LONGER VALID. • © COPYRIGHT 2024 BY THERMACUT® CZECH REPUBLIC. ALL RIGHTS RESERVED.

THERMACUT® REPLACEMENT PARTS SUITABLE FOR KJELLBERG®

HiFocus® 160i | PerCut® 160 / PerCut® 170



PRODUCT BROCHURE WITH DETAILS AT
WWW.THERMACUT.COM

Item	Part No.	Ref. No.	Sh.Ref.No.	Description	Std. Pkg.	Item	Part No.	Ref. No.	Sh.Ref.No.	Description	Std. Pkg.
1.	T-8630	11.835.201.081	Z501	Protection Cap	1	12.	T-10008	11.843.121.412	S2112X	Nozzle 1.2 100A	10
2.	T-8631	11.835.201.1561	Z4015	Swirl Gas Cap 1.5	10		T-10009	11.843.121.414	S2114X	Nozzle 1.4 130A	10
	T-8632	11.835.201.1571	Z4020	Swirl Gas Cap 2.0	10		T-10010	11.843.121.416	S2116X	Nozzle 1.6 160A	10
	T-8885	11.835.201.1551	Z4022	Swirl Gas Cap 2.2	10	13.	T-10011	11.843.111.614	S2514X	Nozzle 1.4 120A	5
	T-8633	11.835.201.1581	Z4025	Swirl Gas Cap 2.5	10		T-9926	11.843.111.616	S2516X	Nozzle 1.6 140A	5
	T-8634	11.835.201.1591	Z4030	Swirl Gas Cap 3.0	10		T-9927	11.843.111.618	S2518X	Nozzle 1.8 160A	5
3.	T-8650	11.835.401.1571	Z4140	Swirl Gas Cap 4.0	10	14.	T-10272	11.842.621.407	R2007	Nozzle 0.7 35A (3D)	10
4.	T-9928	11.835.411.1581	Z4530	Swirl Gas Cap 3.0	10	15.	T-10252	11.842.621.408	R2008	Nozzle 0.8 50A (3D)	10
	T-10153	11.835.411.1580	Z4535	Swirl Gas Cap 3.5	10	OD	T-10273	11.842.621.409	R2009	Nozzle 0.9 70A (3D)	5
	T-9929	11.835.411.1591	Z4540	Swirl Gas Cap 4.0	10		T-10274	11.842.621.410	R2010	Nozzle 1.0 80A (3D)	5
5.	T-10279	11.838.001.1571	Y4020	Swirl Gas Cap 2.0 (3D)	5		T-10275	11.842.621.411	R2011	Nozzle 1.1 90A (3D)	10
6.	T-10294	11.842.601.157	R4020	Swirl Gas Cap 2.0 (3D)	5		T-10276	11.842.621.412	R2012	Nozzle 1.2 100A (3D)	10
	T-10278	11.842.601.155	R4022	Swirl Gas Cap 2.2 (3D)	5		T-10277	11.842.621.414	R2014	Nozzle 1.4 130A (3D)	10
	T-10280	11.842.601.158	R4025	Swirl Gas Cap 2.5 (3D)	5	16.	T-8623	11.835.221.153	Z101	Swirl Ring 0.4 (3×CW)	1
OD	T-10303	11.842.701.158	R4130	Swirl Gas Cap 3.0 (3D)	5	17.	T-8886	11.835.221.154	Z102	Swirl Ring 0.4 (2×CW)	1
	T-10302	11.842.701.159	R4140	Swirl Gas Cap 4.0 (3D)	5	18.	T-9287	11.834.321.153K	Z111	Swirl Ring, Ceramic	1
7.	T-8887	11.842.401.160	S3004	Nozzle Cap 0.4	1		T-8618	11.834.321.153	Z111	Swirl Ring, Vespel®	1
	T-8888	11.842.401.162	S3008	Nozzle Cap 0.8	1	19.	T-8655	11.835.421.303	Z111A	Spacer	2
8.	T-8889	11.842.401.1622	S3028	Nozzle Cap 0.8	1	20.	T-4920	11.843.021.320-AG	S002Y	Cathode, SilverEX®	5
	T-10208	11.842.401.1624	S3048	Nozzle Cap 0.8	1	21.	T-11204*	11.843.021.320-PRO	S002Y	Cathode, Silver PRO	5
9.	T-10328	11.842.401.1621	S3018	Nozzle Cap 0.8	1	22.	T-4924	11.843.121.310-AG	S012X	Cathode, SilverEX®	5
OD NS	T-10298	11.842.601.162 OEM	R3008	Nozzle Cap 0.8	1	23.	T-11853*	11.843.121.310-PRO	S012X	Cathode, Silver PRO	5
OD NS	T-10251	11.842.601.1622 OEM	R3028	Nozzle Cap 0.8 (3D)	1	24.	T-9924	11.842.411.510	S042	Cathode, HiFinox™ (i)	5
10.	T-10000	11.843.021.406	S2006X	Nozzle 0.6 25A	10	25.	T-9925	11.842.511.510	S052	Cathode, FineFocus® (i)	5
	T-10001	11.843.021.407	S2007X	Nozzle 0.7 35A	10	26.	T-4931	11.842.621.310-AG	R002	Cathode, XL, O ₂ , SilverEX®	5
11.	T-10002	11.843.021.408	S2008X	Nozzle 0.8 50/60A	10	27.	T-11851	11.842.621.310-PRO	R002	Cathode, XL, O ₂ , Silver PRO	5
	T-10003	11.843.021.409	S2009X	Nozzle 0.9 70/80A	10	28.	T-11839	11.842.721.310-AG	R012	Cathode, O ₂ , SilverEX®	5
	T-10004	11.843.021.410	S2010X	Nozzle 1.0 80/90A	10	29.	T-10207	11.842.401.152	S901	Cooling Tube	1
	T-9699	11.843.021.411	S2011X	Nozzle 1.1 90/100A	10	30.	T-11161	11.842.601.152	R901	Cooling Tube	1
	T-10005	11.843.021.412	S2012X	Nozzle 1.2 100/130A	10	31.	T-11322	12.40320		Wrench for Swirl Ring	1
	T-10006	11.843.021.414	S2014X	Nozzle 1.4 130/160A	10	32.	Torches, cable leads. See following pages for details.				
	T-10007	11.843.021.416	S2016X	Nozzle 1.6 160A	10	33.	Coolant Liquid. Details on the Accessories page.				

OD ON DEMAND – WE DO NOT KEEP THESE PARTS IN STOCK, COST IS SET ACCORDING TO THE ORDERED QUANTITY, DELIVERY TIME MAY DIFFER FROM STANDARD PRODUCTS.

(i) THIS PART MAY NOT BE DISTRIBUTED ON THE GERMAN MARKET. THERMACUT® ACCEPTS NO RESPONSIBILITY IN CASE OF INDIRECT SALES TO GERMANY.

***** FULLY INTERCHANGEABLE AND COMPATIBLE WITH ORIGINAL PARTS, BUT DIFFERS FROM ORIGINAL DESIGN

NS NOT SHOWN IN THE PICTURE

-PRO TECHNOLOGY OF SILVER INSERTED COPPER ELECTRODE BODY, WHICH SIGNIFICANTLY DECREASES ELECTRODE COSTS WITH SIMILAR WORK PERFORMANCE COMPARED TO FULL SILVER ELECTRODES.

THERMACUT®, FHT-EX® AND EX-TRAFIRE® ARE REGISTERED TRADEMARKS OF THERMACUT, K. S. AND MAY BE REGISTERED IN CZECH REPUBLIC AND/OR OTHER COUNTRIES. ALL OTHER TRADEMARKS ARE PROPERTIES OF THEIR RESPECTIVE OWNERS. THERMACUT IS NO WAY AFFILIATED WITH KJELLBERG®.

MOST THERMACUT PARTS ARE MADE FOR OR BY AN IBG COMPANY. PARTS INDICATED WITH A OEM ARE ORIGINAL PARTS MANUFACTURED BY THE ABOVE NAMED MANUFACTURER AND ARE BEING RESOLD BY THERMACUT. THERMACUT RESERVES THE RIGHT TO SUBSTITUTE OEM PARTS IN PLACE OF THERMACUT PARTS.

VALID FROM SEPTEMBER 2024 • PREVIOUS VERSION IS NO LONGER VALID. • © COPYRIGHT 2024 BY THERMACUT® CZECH REPUBLIC. ALL RIGHTS RESERVED.

**THERMACUT® REPLACEMENT PARTS SUITABLE FOR
KJELLBERG®
HiFocus® 160i | PerCut® 160 / PerCut® 170 TORCHES AND CABLE LEADS**

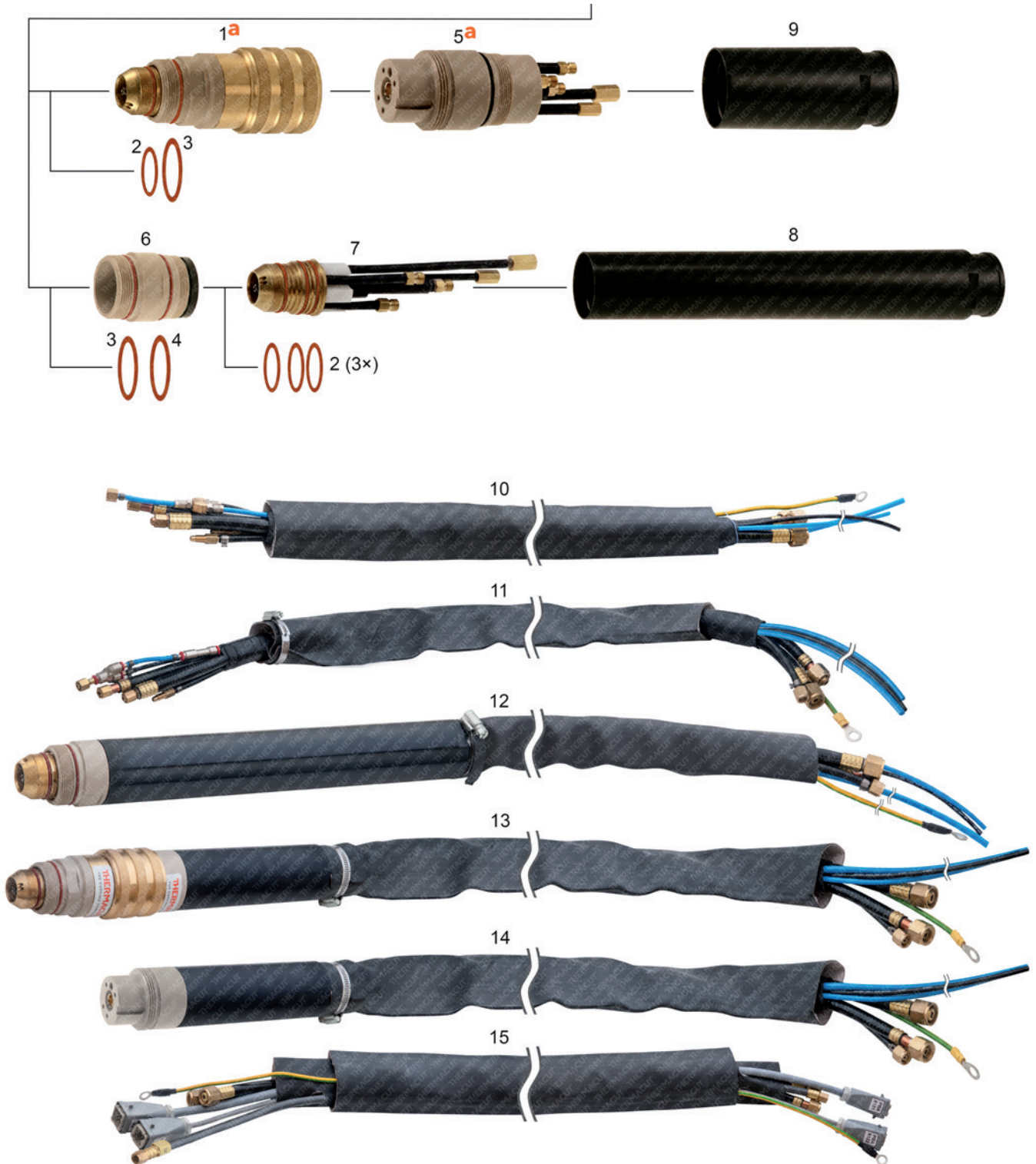

THERMACUT®, FHT-EX® AND EX-TRAFIRE® ARE REGISTERED TRADEMARKS OF THERMACUT, K. S. AND MAY BE REGISTERED IN CZECH REPUBLIC AND/OR OTHER COUNTRIES. ALL OTHER TRADEMARKS ARE PROPERTIES OF THEIR RESPECTIVE OWNERS. THERMACUT IS NO WAY AFFILIATED WITH KJELLBERG®. MOST THERMACUT PARTS ARE MADE FOR OR BY AN IBG COMPANY. PARTS INDICATED WITH A OEM ARE ORIGINAL PARTS MANUFACTURED BY THE ABOVE NAMED MANUFACTURER AND ARE BEING RESOLD BY THERMACUT. THERMACUT RESERVES THE RIGHT TO SUBSTITUTE OEM PARTS IN PLACE OF THERMACUT PARTS. VALID FROM SEPTEMBER 2024 • PREVIOUS VERSION IS NO LONGER VALID. • © COPYRIGHT 2024 BY THERMACUT® CZECH REPUBLIC. ALL RIGHTS RESERVED.

THERMACUT® REPLACEMENT PARTS SUITABLE FOR KJELLBERG®

HiFocus® 160i | PerCut® 160 / PerCut® 170 TORCHES AND CABLE LEADS

Item	Part No.	Ref. No.	Description	Std. Pkg.	Item	Part No.	Ref. No.	Description	Std. Pkg.	
a	1.	T-10174	11.843.021.100-UR	PerCut® 170 Front Part	1		KT-1179	11.842.421.700A	PerCut® 160-2 Cable Leads 1.75m	1
	2.	N-12300	10.505.916	O-Ring	1	11.	KT-1220	K.PERCUT170-2.1,75M.K	PerCut® 170-2 Cable Leads 1.75m	1
	3.	T-8640	10.505.946	O-Ring	10		T-13369	K.PERCUT170-2.3M.K	PerCut® 170-2 Cable Leads 2.3m	1
	4.	N-18132	N-18132	O-Ring	1	12.	KT-1051	11.842.421.1015	PerCut® 160-2 Mach. Torch with Leads 1.75m	1
a	5.	T-10175	11.822.583-UR	PerCut® 170 Adaptor	1	13.	KT-1064	11.843.021.1015-UR	PerCut® 170-2-UR Mach. Torch w/ Leads 1.75m	1
	6.	T-10282	11.842.221.100-10	Tube PerCut® 160	1		KT-1065	K.PERCUT170.3M	PerCut® 170-2-UR Mach. Torch with Leads 3m	1
	7.	T-9933	11.842.221.100	Torch PerCut® 160	1		KT-1218	K.PERCUT170-2.6M	PerCut® 170-2-UR Mach. Torch with Leads 6m	1
	8.	T-9857	11.842.421.250	Tube PerCut® 160	1	14.	KT-1265	K.PERCUT170-2.A	PerCut® 170 Adaptor with Leads 1.75m	1
	9.	T-10176	11.843.021.250	Tube PerCut® 170	1	15.	KT-1381	11.825.710.1	PBL-H160 Lead Set, 10m	1
NS	T-9755	11.835.201.077	Clamping Bush	1		KT-1308	11.825.715.1	PBL-H160 Lead Set, 15m	1	
NS	T-9756	11.835.201.076	Outer Bush	1		Different types of cable leads available on request				
	10.	KT-1271	K.PERCUT160.1,5M	PerCut® 160-2 Mach. Torch with Leads 1.5m	1					

a THERMACUT® TORCH & ADAPTOR HAVE TO BE USED AS A SET, CONECTORS ARE NOT COMPATIBLE WITH OEM CONECTORS.

NS NOT SHOWN IN THE PICTURE

W/ WITH

THERMACUT®, FHT-EX® AND EX-TRAFIRE® ARE REGISTERED TRADEMARKS OF THERMACUT, K. S. AND MAY BE REGISTERED IN CZECH REPUBLIC AND/OR OTHER COUNTRIES. ALL OTHER TRADEMARKS ARE PROPERTIES OF THEIR RESPECTIVE OWNERS. THERMACUT IS NO WAY AFFILIATED WITH KJELLBERG®. MOST THERMACUT PARTS ARE MADE FOR OR BY AN IBG COMPANY. PARTS INDICATED WITH A OEM ARE ORIGINAL PARTS MANUFACTURED BY THE ABOVE NAMED MANUFACTURER AND ARE BEING RESOLD BY THERMACUT. THERMACUT RESERVES THE RIGHT TO SUBSTITUTE OEM PARTS IN PLACE OF THERMACUT PARTS. VALID FROM SEPTEMBER 2024 • PREVIOUS VERSION IS NO LONGER VALID. • © COPYRIGHT 2024 BY THERMACUT® CZECH REPUBLIC. ALL RIGHTS RESERVED.

**THERMACUT® REPLACEMENT PARTS SUITABLE FOR
KJELLBERG®**

HiFocus® 160i, HiFocus® 161i, HiFocus® 280i, HiFocus® 360i, HiFocus® 440i

PerCut® 200 / 201 / 210 / 211 / 450M / 451M MILD STEEL

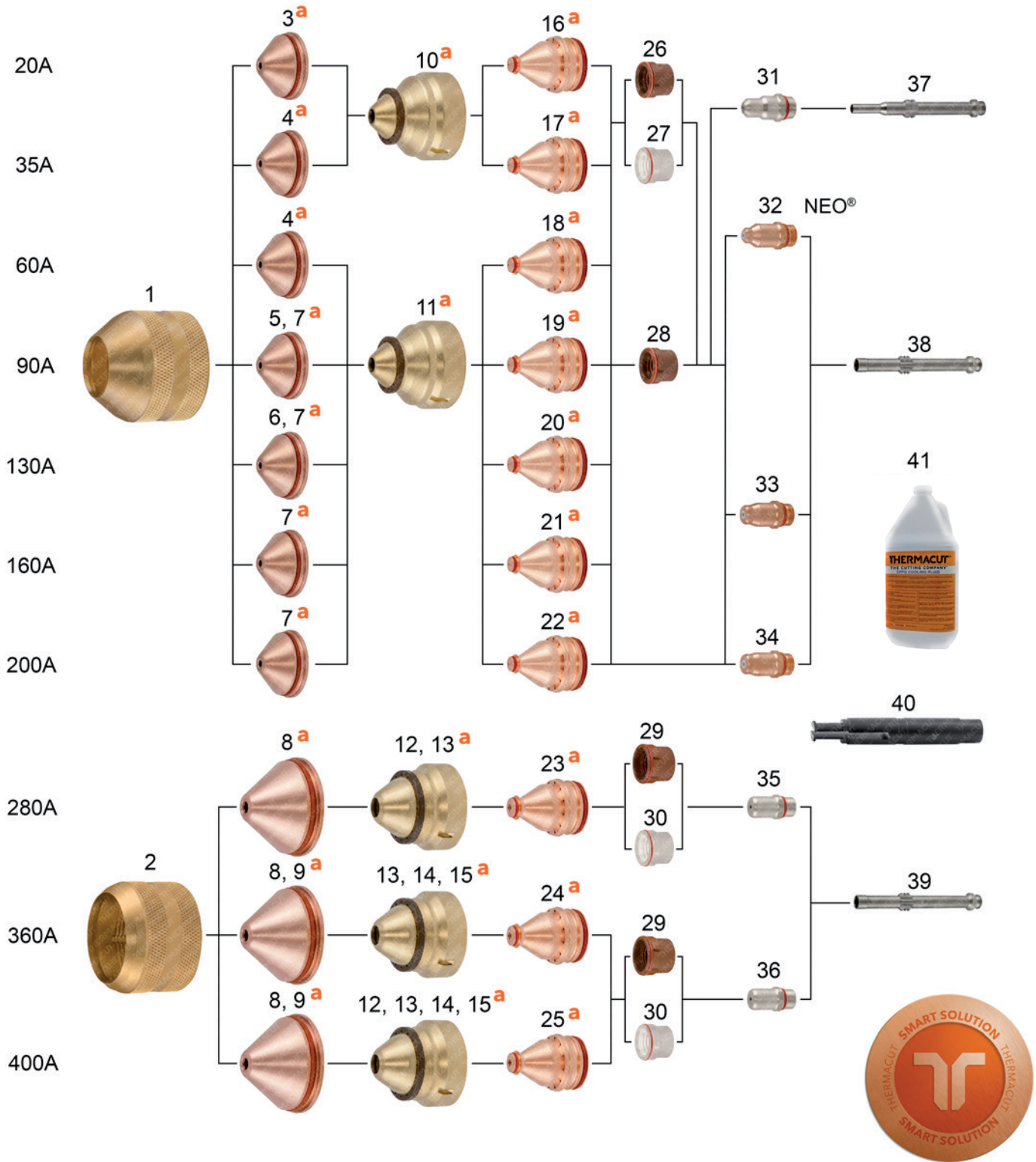

THERMACUT®, FHT-EX® AND EX-TRAFIRE® ARE REGISTERED TRADEMARKS OF THERMACUT, K. S. AND MAY BE REGISTERED IN CZECH REPUBLIC AND/OR OTHER COUNTRIES. ALL OTHER TRADEMARKS ARE PROPERTIES OF THEIR RESPECTIVE OWNERS. THERMACUT IS NO WAY AFFILIATED WITH KJELLBERG®. MOST THERMACUT PARTS ARE MADE FOR OR BY AN IBG COMPANY. PARTS INDICATED WITH A OEM ARE ORIGINAL PARTS MANUFACTURED BY THE ABOVE NAMED MANUFACTURER AND ARE BEING RESOLD BY THERMACUT. THERMACUT RESERVES THE RIGHT TO SUBSTITUTE OEM PARTS IN PLACE OF THERMACUT PARTS. VALID FROM SEPTEMBER 2024 • PREVIOUS VERSION IS NO LONGER VALID. • © COPYRIGHT 2024 BY THERMACUT® CZECH REPUBLIC. ALL RIGHTS RESERVED.

THERMACUT® REPLACEMENT PARTS SUITABLE FOR KJELLBERG®

HiFocus® 160i, HiFocus® 161i, HiFocus® 280i, HiFocus® 360i, HiFocus® 440i
PerCut® 200 / 201 / 210 / 211 / 450M / 451M MILD STEEL



PRODUCT BROCHURE WITH DETAILS AT
WWW.THERMACUT.COM

Item	Part No.	Ref. No.	Sh.Ref.No.	Description	Std. Pkg.	Item	Part No.	Ref. No.	Sh.Ref.No.	Description	Std. Pkg.
1.	T-11221	11.848.201.081	G501	Protection Cap 20-200A	1	a 21.	T-11357	11.848.221.414-UR	G2014Y	Nozzle 1.4mm 160A	1
	T-12010	11.852.201.081	G502	P. Cap 20-200A, PerCut® 451M	1	a 22.	T-11358	11.848.221.416-UR	G2016Y	Nozzle 1.6mm 200A	1
2.	T-11227	11.848.401.081	G521	Protection Cap 280-400A	1	a	T-11835	11.848.221.417-UR	G2017Y	Nozzle 1.7mm 200A	1
	T-12011	11.852.401.081	G522	P. Cap 280-440A, PerCut® 451M	1	a 23.	T-11359	11.848.421.426-UR	G2326Y	Nozzle 2.6mm 280A	1
a 3.	T-11368	11.848.201.1515-UR	G4015	Swirl Gas Cap 20A	10	a 24.	T-11360	11.848.421.430-UR	G2330Y	Nozzle 3.0mm 360A	1
a 4.	T-11369	11.848.201.1520-UR	G4020	Swirl Gas Cap 35/60A	10	a 25.	T-11361	11.848.421.431-UR	G2331Y	Nozzle 3.1mm 400A	1
a 5.	T-11371	11.848.201.1525-UR	G4025	Swirl Gas Cap 90A	10	26.	T-11223	11.848.221.145	G101	Swirl Ring	1
a 6.	T-11370	11.848.201.1522-UR	G4022	Swirl Gas Cap 130A	10	27.	T-12626	11.848.221.145C	G101C	Swirl Ring Ceramic	1
a 7.	T-11372	11.848.201.1530-UR	G4030	Swirl Gas Cap 90-200A	10	28.	T-11224	11.848.221.146	G102	Swirl Ring	1
a	T-11968	11.848.201.1535-UR	G4035	Swirl Gas Cap 200A	10	29.	T-11230	11.848.421.145	G121	Swirl Ring	1
a	T-11969	11.848.201.1540-UR	G4040	Swirl Gas Cap 200A	10		T-11231	11.848.421.149	G125	Swirl Ring	1
a 8.	T-11373	11.848.401.1550-UR	G4350	Swirl Gas Cap 280-400A	1	30.	T-12627	11.848.421.145C	G121C	Swirl Ring Ceramic	1
a 9.	T-11374	11.848.401.1555-UR	G4355	Swirl Gas Cap 360-400A	1	31.	T-11225*	11.848.221.300-AG	G002Y	Cathode, SilverEX-®	5
a 10.	T-11362	11.848.201.1604-UR	G3004	Retaining Cap 20-35A	1	32.	T-11858	11.848.231.320-PRO	G011Y	Cathode, Silver PRO	5
a 11.	T-11363	11.848.201.1628-UR	G3028	Retaining Cap 60-200A	1	33.	T-11859	11.848.231.350-PRO	G015Y	Cathode, Silver PRO	5
a 12.	T-11367	11.848.401.1649-UR	G3249	Retaining Cap 280/400A	1	34.	T-11860	11.848.231.360-PRO	G016Y	Cathode, Silver PRO	5
a 13.	T-11365	11.848.401.1619-UR	G3219	Retaining Cap 280-400A	1	35.	T-11232*	11.848.421.310-AG	G032Y	Cathode, SilverEX-®	5
a 14.	T-11366	11.848.401.1629-UR	G3229	Retaining Cap 360/400A	1	36.	T-11233*	11.848.421.330-AG	G034Y	Cathode, SilverEX-®	5
a 15.	T-11364	11.848.401.1609-UR	G3209	Retaining Cap 360/400A	1	37.	T-11222	11.848.201.142	G901Y	Cooling Tube 20-200A	1
a 16.	T-11352	11.848.221.406-UR	G2006Y	Nozzle 0.6mm 20A	1	38.	T-11847	11.852.201.142	G902Y	Cooling Tube	1
a 17.	T-11353	11.848.221.407-UR	G2007Y	Nozzle 0.7mm 35A	1	39.	T-11228	11.848.401.142	G931Y	Cooling Tube 280-400A	1
a 18.	T-11354	11.848.221.408-UR	G2008Y	Nozzle 0.8mm 60A	1	40.	T-11322	12.40320		Wrench for Swirl Ring	1
a 19.	T-11355	11.848.221.410-UR	G2010Y	Nozzle 1.0mm 90A	1	41.	Coolant Liquid. Details on the Accessories page.				
a 20.	T-11356	11.848.221.412-UR	G2012Y	Nozzle 1.2mm 130A	1						

* FULLY INTERCHANGEABLE AND COMPATIBLE WITH ORIGINAL PARTS, BUT DIFFERS FROM ORIGINAL DESIGN

a MUST BE USED ONLY AS A SET OF SWIRL GAS CAP, RETAINING CAP AND NOZZLE, THIS COMPLETE SET IS INTERCHANGEABLE AND COMPATIBLE WITH ORIGINAL PARTS

THERMACUT® DESIGN IS PROTECTED BY UTILITY PATENT

-PRO SILVER PRO TECHNOLOGY INCREASES ELECTRODE LIFETIME SIGNIFICANTLY COMPARED TO STANDARD COPPER ELECTRODES

SMART SOLUTION - DESIGN IMPROVEMENTS THAT BRINGS ADDED VALUE SUCH AS IMPROVED LIFETIME OF CONSUMABLES, EXCELLENT CUT QUALITY, SPEED OR BETTER COST EFFECTIVENESS OF YOUR SYSTEM

THERMACUT®, FHT-EX® AND EX-TRAFIRE® ARE REGISTERED TRADEMARKS OF THERMACUT, K. S. AND MAY BE REGISTERED IN CZECH REPUBLIC AND/OR OTHER COUNTRIES. ALL OTHER TRADEMARKS ARE PROPERTIES OF THEIR RESPECTIVE OWNERS. THERMACUT IS NO WAY AFFILIATED WITH KJELLBERG®.

MOST THERMACUT PARTS ARE MADE FOR OR BY AN IBG COMPANY. PARTS INDICATED WITH A OEM ARE ORIGINAL PARTS MANUFACTURED BY THE ABOVE NAMED MANUFACTURER AND ARE BEING RESOLD BY THERMACUT. THERMACUT RESERVES THE RIGHT TO SUBSTITUTE OEM PARTS IN PLACE OF THERMACUT PARTS.

VALID FROM SEPTEMBER 2024 • PREVIOUS VERSION IS NO LONGER VALID. • © COPYRIGHT 2024 BY THERMACUT® CZECH REPUBLIC. ALL RIGHTS RESERVED.

**THERMACUT® REPLACEMENT PARTS SUITABLE FOR
KJELLBERG®**

**HiFocus® 160i, HiFocus® 161i, HiFocus® 280i, HiFocus® 360i, HiFocus® 440i
PerCut® 200 / 201 / 210 / 211 / 450M / 451M STAINLESS STEEL**

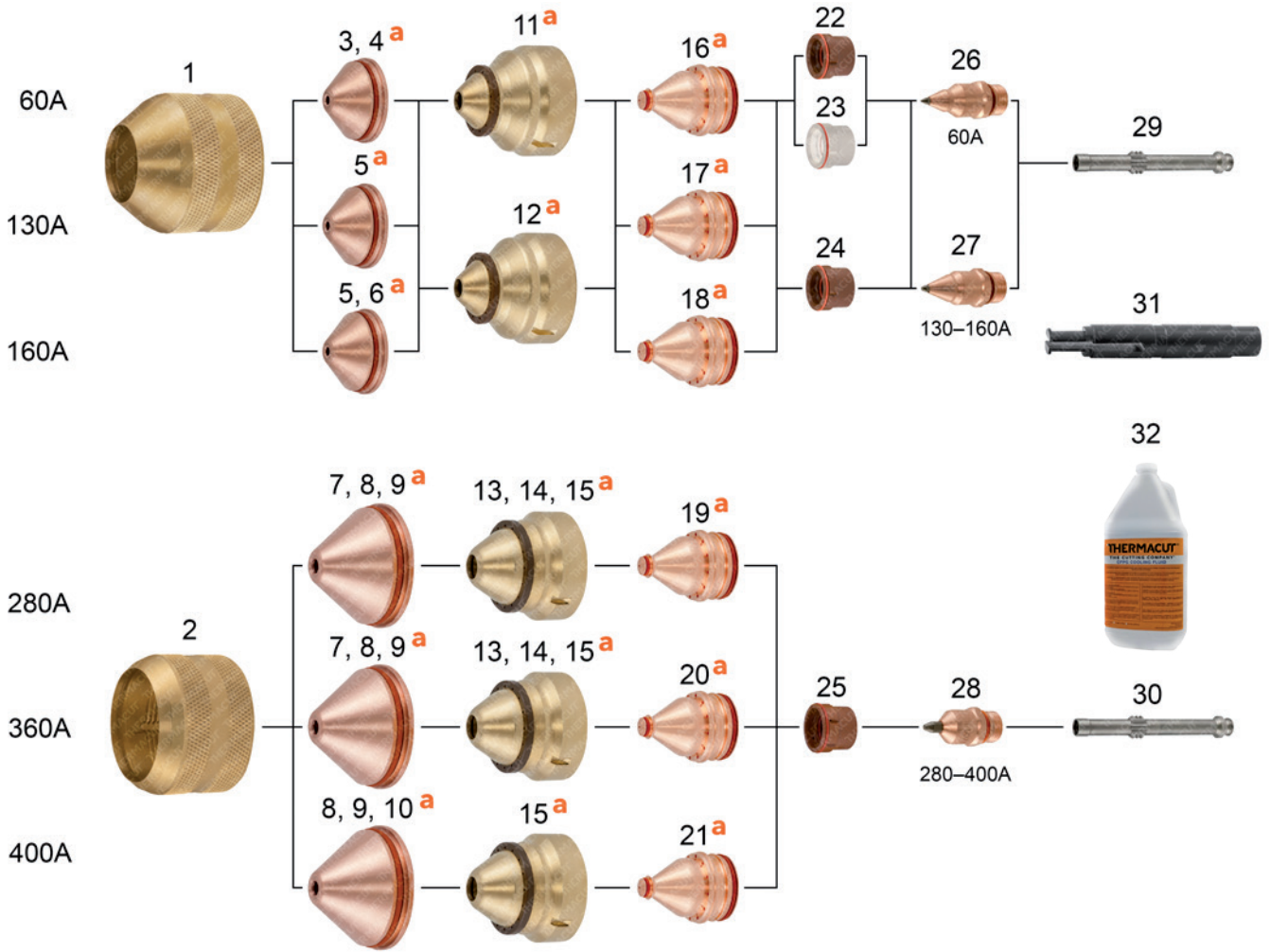

THERMACUT®, FHT-EX® AND EX-TRAFIRE® ARE REGISTERED TRADEMARKS OF THERMACUT, K. S. AND MAY BE REGISTERED IN CZECH REPUBLIC AND/OR OTHER COUNTRIES. ALL OTHER TRADEMARKS ARE PROPERTIES OF THEIR RESPECTIVE OWNERS. THERMACUT IS NO WAY AFFILIATED WITH KJELLBERG®. MOST THERMACUT PARTS ARE MADE FOR OR BY AN IBG COMPANY. PARTS INDICATED WITH A OEM ARE ORIGINAL PARTS MANUFACTURED BY THE ABOVE NAMED MANUFACTURER AND ARE BEING RESOLD BY THERMACUT. THERMACUT RESERVES THE RIGHT TO SUBSTITUTE OEM PARTS IN PLACE OF THERMACUT PARTS. VALID FROM SEPTEMBER 2024 • PREVIOUS VERSION IS NO LONGER VALID. • © COPYRIGHT 2024 BY THERMACUT® CZECH REPUBLIC. ALL RIGHTS RESERVED.

THERMACUT® REPLACEMENT PARTS SUITABLE FOR KJELLBERG®

HiFocus® 160i, HiFocus® 161i, HiFocus® 280i, HiFocus® 360i, HiFocus® 440i
PerCut® 200 / 201 / 210 / 211 / 450M / 451M STAINLESS STEEL



PRODUCT BROCHURE WITH DETAILS AT
WWW.THERMACUT.COM

Item	Part No.	Ref. No.	Sh.Ref.No.	Description	Std. Pkg.	Item	Part No.	Ref. No.	Sh.Ref.No.	Description	Std. Pkg.
1.	T-11221	11.848.201.081	G501	Protection Cap 60-160A	1	a 17.	T-12006	11.848.311.614-UR	G2514	Nozzle 1.4mm 130A (i)	1
2.	T-11227	11.848.401.081	G521	Protection Cap 280-440A	1	a 18.	T-12007	11.848.311.615-UR	G2515	Nozzle 1.5mm 160A (i)	1
a 3.	T-11370	11.848.201.1522-UR	G4022	Swirl Gas Cap 60A (1-5mm)	10	a 19.	T-11995	11.848.411.625-UR	G2725	Nozzle 2.5mm 280A (i)	1
a 4.	T-11371	11.848.201.1525-UR	G4025	Swirl Gas Cap 60A (6mm)	10	a 20.	T-12009	11.848.411.627-UR	G2727	Nozzle 2.7mm 360A (i)	1
a 5.	T-11372	11.848.201.1530-UR	G4030	Swirl Gas Cap 130/160A (5-20mm)	10	a 21.	T-12005	11.848.411.629-UR	G2729	Nozzle 2.9mm 440A (i)	1
a 6.	T-11968	11.848.201.1535-UR	G4035	Swirl Gas Cap 160A (12-15mm)	10	22.	T-11223	11.848.221.145	G101	Swirl Ring 60A	1
a 7.	T-12001	11.848.401.1535-UR	G4335	Swirl Gas Cap 280/360A (15-30mm)	1	23.	T-12626	11.848.221.145C	G101C	Swirl Ring Ceramic	1
a 8.	T-12003	11.848.401.1540-UR	G4340	Swirl Gas Cap 280-440A (20-40mm)	1	24.	T-11998	11.848.221.149	G105	Swirl Ring 130/160A	1
a 9.	T-12002	11.848.401.1545-UR	G4345	Swirl Gas Cap 280-440A (40-80mm)	1	25.	T-11231	11.848.421.149	G125	Swirl Ring 280-440A	1
a 10.	T-11373	11.848.401.1550-UR	G4350	Swirl Gas Cap 440A (80-120mm)	1	26.	T-12000	11.848.211.510	G042	Cathode 60A (i)	5
a 11.	T-11997	11.848.201.1608-UR	G3008	Retaining Cap 35-80A (1-10mm)	1	27.	T-11999	11.848.311.510	G052	Cathode 130/160A (i)	5
a 12.	T-11996	11.848.201.1618-UR	G3018	Retaining Cap 130/160A (5-20mm)	1	28.	T-12004	11.848.411.500	G071	Cathode 280-440A (i)	5
a 13.	T-11366	11.848.401.1629-UR	G3229	Retaining Cap 280/360A (15-20mm)	1	29.	T-12008	11.848.211.142	G941	Cooling Tube 60-160A	1
a 14.	T-11365	11.848.401.1619-UR	G3219	Retaining Cap 280/360A (20-30mm)	1	30.	T-11229	11.848.411.142	G971	Cooling Tube 280-440A	1
a 15.	T-11364	11.848.401.1609-UR	G3209	Retaining Cap 280/440A (40-120mm)	1	31.	T-11322	12.40320		Wrench for Swirl Ring	1
a 16.	T-11355	11.848.221.410-UR	G2010Y	Nozzle 1.0mm 60A (i)	1	32.	Coolant Liquid. Details on the Accessories page.				

* FULLY INTERCHANGEABLE AND COMPATIBLE WITH ORIGINAL PARTS, BUT DIFFERS FROM ORIGINAL DESIGN

(i) THIS PARTS MAY NOT BE DISTRIBUTED ON THE GERMAN MARKET. THERMACUT® ACCEPTS NO RESPONSIBILITY IN CASE OF INDIRECT SALES TO GERMANY.

a MUST BE USED ONLY AS A SET OF SWIRL GAS CAP, RETAINING CAP AND NOZZLE, THIS COMPLETE SET IS INTERCHANGEABLE AND COMPATIBLE WITH ORIGINAL PARTS

THERMACUT® DESIGN IS PROTECTED BY UTILITY PATENT

-PRO SILVER PRO TECHNOLOGY INCREASES ELECTRODE LIFETIME SIGNIFICANTLY COMPARED TO STANDARD COPPER ELECTRODES

SMART SOLUTION - DESIGN IMPROVEMENTS THAT BRINGS ADDED VALUE SUCH AS IMPROVED LIFETIME OF CONSUMABLES, EXCELLENT CUT QUALITY, SPEED OR BETTER COST EFFECTIVENESS OF YOUR SYSTEM

THERMACUT®, FHT-EX® AND EX-TRAFIRE® ARE REGISTERED TRADEMARKS OF THERMACUT, K. S. AND MAY BE REGISTERED IN CZECH REPUBLIC AND/OR OTHER COUNTRIES. ALL OTHER TRADEMARKS ARE PROPERTIES OF THEIR RESPECTIVE OWNERS. THERMACUT IS NO WAY AFFILIATED WITH KJELLBERG®.

MOST THERMACUT PARTS ARE MADE FOR OR BY AN IBG COMPANY. PARTS INDICATED WITH A OEM ARE ORIGINAL PARTS MANUFACTURED BY THE ABOVE NAMED MANUFACTURER AND ARE BEING RESOLD BY THERMACUT. THERMACUT RESERVES THE RIGHT TO SUBSTITUTE OEM PARTS IN PLACE OF THERMACUT PARTS.

VALID FROM SEPTEMBER 2024 • PREVIOUS VERSION IS NO LONGER VALID. • © COPYRIGHT 2024 BY THERMACUT® CZECH REPUBLIC. ALL RIGHTS RESERVED.

**THERMACUT® REPLACEMENT PARTS SUITABLE FOR
KJELLBERG®**

HiFocus® 280 / HiFocus® 360, HiFocus® 440 | PerCut® 370.1, PerCut® 370.2

REPLACEMENT PARTS SUITABLE FOR PerCut® 370.1

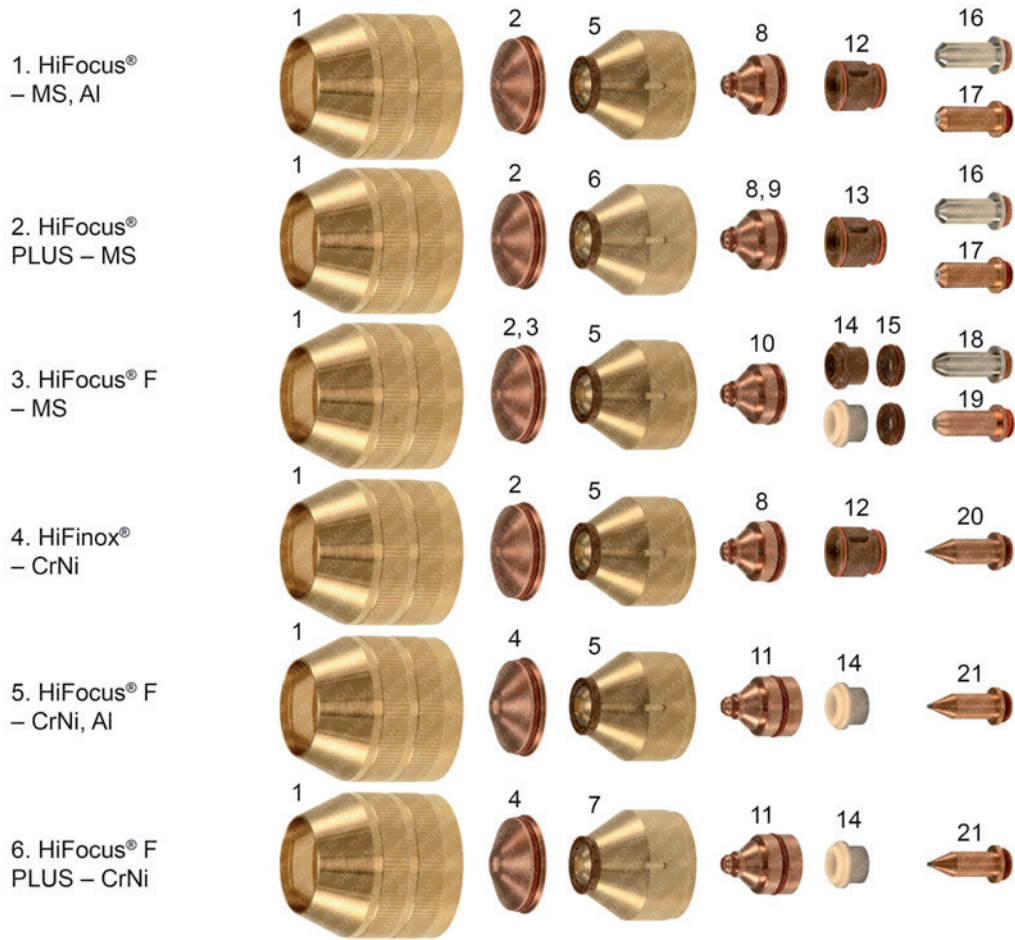

REPLACEMENT PARTS SUITABLE FOR PerCut® 370.2

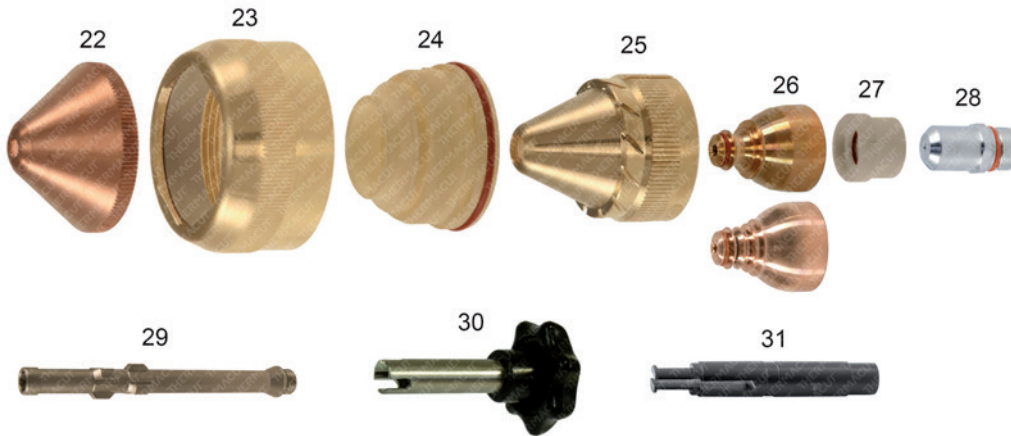

THERMACUT®, FHT-EX® AND EX-TRAFIRE® ARE REGISTERED TRADEMARKS OF THERMACUT, K. S. AND MAY BE REGISTERED IN CZECH REPUBLIC AND/OR OTHER COUNTRIES. ALL OTHER TRADEMARKS ARE PROPERTIES OF THEIR RESPECTIVE OWNERS. THERMACUT IS NO WAY AFFILIATED WITH KJELLBERG®. MOST THERMACUT PARTS ARE MADE FOR OR BY AN IBG COMPANY. PARTS INDICATED WITH A OEM ARE ORIGINAL PARTS MANUFACTURED BY THE ABOVE NAMED MANUFACTURER AND ARE BEING RESOLD BY THERMACUT. THERMACUT RESERVES THE RIGHT TO SUBSTITUTE OEM PARTS IN PLACE OF THERMACUT PARTS. VALID FROM SEPTEMBER 2024 • PREVIOUS VERSION IS NO LONGER VALID. • © COPYRIGHT 2024 BY THERMACUT® CZECH REPUBLIC. ALL RIGHTS RESERVED.

THERMACUT® REPLACEMENT PARTS SUITABLE FOR KJELLBERG®

HiFocus® 280 / HiFocus® 360, HiFocus® 440 | PerCut® 370.1, PerCut® 370.2

REPLACEMENT PARTS SUITABLE FOR PerCut® 370.1

Item	Part No.	Ref. No.	Sh.Ref.No.	Description	Std. Pkg.	Item	Part No.	Ref. No.	Sh.Ref.No.	Description	Std. Pkg.
1.	T-8630	11.835.201.081	Z501	Protection Cap	1		T-10005	11.843.021.412	S2012X	Nozzle 1.2 100/130A	10
2.	T-8631	11.835.201.1561	Z4015	Swirl Gas Cap 1.5	10		T-10006	11.843.021.414	S2014X	Nozzle 1.4 130/160A	10
	T-8632	11.835.201.1571	Z4020	Swirl Gas Cap 2.0	10		T-10007	11.843.021.416	S2016X	Nozzle 1.6 160A	10
	T-8885	11.835.201.1551	Z4022	Swirl Gas Cap 2.2	10	10.	T-10008	11.843.121.412	S2112X	Nozzle 1.2 100A	10
	T-8633	11.835.201.1581	Z4025	Swirl Gas Cap 2.5	10		T-10009	11.843.121.414	S2114X	Nozzle 1.4 130A	10
	T-8634	11.835.201.1591	Z4030	Swirl Gas Cap 3.0	10		T-10010	11.843.121.416	S2116X	Nozzle 1.6 160A	10
3.	T-8650	11.835.401.1571	Z4140	Swirl Gas Cap 4.0	10	11.	T-10011	11.843.111.614	S2514X	Nozzle 1.4 120A	5
4.	T-9928	11.835.411.1581	Z4530	Swirl Gas Cap 3.0	10		T-9926	11.843.111.616	S2516X	Nozzle 1.6 140A	5
	T-10153	11.835.411.1580	Z4535	Swirl Gas Cap 3.5	10		T-9927	11.843.111.618	S2518X	Nozzle 1.8 160A	5
	T-9929	11.835.411.1591	Z4540	Swirl Gas Cap 4.0	10	12.	T-8623	11.835.221.153	Z101	Swirl Ring 0.4 (3×CW)	1
5.	T-8887	11.842.401.160	S3004	Nozzle Cap 0.4	1	13.	T-8886	11.835.221.154	Z102	Swirl Ring 0.4 (2×CW)	1
	T-8888	11.842.401.162	S3008	Nozzle Cap 0.8	1	14.	T-9287	11.834.321.153K	Z111	Swirl Ring, Ceramic	1
6.	T-8889	11.842.401.1622	S3028	Nozzle Cap 0.8	1		T-8618	11.834.321.153	Z111	Swirl Ring, Vespel®	1
	T-10208	11.842.401.1624	S3048	Nozzle Cap 0.8	1	15.	T-8655	11.835.421.303	Z111A	Spacer	2
7.	T-10328	11.842.401.1621	S3018	Nozzle Cap 0.8	1	16.	T-4920	11.843.021.320-AG	S002Y	Cathode, SilverEX®	5
8.	T-10000	11.843.021.406	S2006X	Nozzle 0.6 25A	10	17.	T-11204**	11.843.021.320-PRO	S002Y	Cathode, Silver PRO	5
	T-10001	11.843.021.407	S2007X	Nozzle 0.7 35A	10	18.	T-4924	11.843.121.310-AG	S012X	Cathode, SilverEX®	5
9.	T-10002	11.843.021.408	S2008X	Nozzle 0.8 50/60A	10	19.	T-11853**	11.843.121.310-PRO	S012X	Cathode, Silver PRO	5
	T-10003	11.843.021.409	S2009X	Nozzle 0.9 70/80A	10	20.	T-9924	11.842.411.510	S042	Cathode, HiFinox™ (i)	5
	T-10004	11.843.021.410	S2010X	Nozzle 1.0 80/90A	10	21.	T-9925	11.842.511.510	S052	Cathode, FineFocus® (i)	5
	T-9699	11.843.021.411	S2011X	Nozzle 1.1 90/100A	10	31.	T-11322	12.40320		Wrench for Swirl Ring	1

REPLACEMENT PARTS SUITABLE FOR PerCut® 370.2

Item	Part No.	Ref. No.	Sh.Ref.No.	Description	Std. Pkg.	Item	Part No.	Ref. No.	Sh.Ref.No.	Description	Std. Pkg.
22.	T-10591	11.833.101.1550	V4330	Swirl Gas Cap 3.0	1		T-10562	11.846.921.427	T2127Y	Nozzle 300A, O ₂ , repl. 11.836.921.427 (i)	10
	T-10220	11.833.101.155	V4335	Swirl Gas Cap 3.5	1		T-10563	11.846.921.430	T2130Y	Nozzle 360A, O ₂ , repl. 11.836.921.430 (i)	10
	T-10221	11.833.101.156	V4340	Swirl Gas Cap 4.0	1		T-10927**	11.846.921.415-UR	T2115Y	Nozzle 120A, O ₂ , repl. 11.836.921.415	10
	T-10222	11.833.101.157	V4345	Swirl Gas Cap 4.5	1		T-10928**	11.846.921.420-UR	T2120Y	Nozzle 200A, O ₂ , repl. 11.836.921.420	10
	T-10223	11.833.101.158	V4350	Swirl Gas Cap 5.0	1		T-10929**	11.846.921.425-UR	T2125Y	Nozzle 250A, O ₂ , repl. 11.836.921.425	10
	T-10224	11.833.101.159	V4360	Swirl Gas Cap 6.0	1		T-10930**	11.846.921.427-UR	T2127Y	Nozzle 300A, O ₂ , repl. 11.836.921.427	10
23.	T-10470	11.841.721.081	T502	Protection Cap PerCut® 370.2	1		T-10931**	11.846.921.430-UR	T2130Y	Nozzle 360A, O ₂ , repl. 11.836.921.430	10
24.	N-18267	11.836.921.271	T522	Insulator PerCut® 370.2	1	27.	T-10466	11.836.921.1542	T104	Swirl Ring (3×0.4 CW)	1
24a.	N-18371	N-18371		O-Ring	1		T-10672	11.836.921.153	T101	Swirl Ring (6×0.8 CW), Vespel®	1
25.	T-10214	11.836.901.163	T3030	Nozzle Cap (12×1.5 30° CW)	1		T-10464	11.836.921.154	T102	Swirl Ring (3×0.8 CW)	1
	T-10215	11.836.901.164	T3045	Nozzle Cap (12×1.5 45° CW)	1	OD	TN-0004	11.836.921.153	T101	Swirl Ring (6×0.8 CW), Ceramic	1
OD	T-10217	11.836.901.1641	T3145	Nozzle Cap (12×1.5 45° CCW)	1	*28.	T-10804*	11.844.921.300-AG	T012Y	Cathode, SilverEX®	5
	T-10216	11.836.901.165	T3060	Nozzle Cap (12×1.5 60° CW)	1	*29.	T-10558*	11.844.901.152	T902Y	Cooling Tube	1
26.	T-10559	11.846.921.415	T2115Y	Nozzle 120A, O ₂ , repl. 11.836.921.415 (i)	10	30.	T-10564	12.38180		Wrench for Cooling Tube	1
	T-10560	11.846.921.420	T2120Y	Nozzle 200A, O ₂ , repl. 11.836.921.420 (i)	10	31.	T-11322	12.40320		Wrench for Swirl Ring	1
	T-10561	11.846.921.425	T2125Y	Nozzle 250A, O ₂ , repl. 11.836.921.425 (i)	10						

- OD ON DEMAND – WE DO NOT KEEP THESE PARTS IN STOCK, COST IS SET ACCORDING TO THE ORDERED QUANTITY, DELIVERY TIME MAY DIFFER FROM STANDARD PRODUCTS.
- (i) THIS PART MAY NOT BE DISTRIBUTED ON THE GERMAN MARKET. THERMACUT® ACCEPTS NO RESPONSIBILITY IN CASE OF INDIRECT SALES TO GERMANY.
- * FULLY INTERCHANGEABLE AND COMPATIBLE WITH ORIGINAL PARTS, BUT DIFFERS FROM ORIGINAL DESIGN
- ** A UNIQUE DESIGN WHICH ENHANCES PERFORMANCE AND DIFFERS FROM OEM DESIGNS
- CCW COUNTER CLOCK WISE GAS SWIRLING, USE OF CCW PARTS WILL MAKE CUT ANGLE ON THE OPPOSITE SIDE, THAN WITH STANDARD CLOCK WISE (CW) SWIRLING PARTS.
- PRO TECHNOLOGY OF SILVER INSERTED COPPER ELECTRODE BODY, WHICH SIGNIFICANTLY DECREASES ELECTRODE COSTS WITH SIMILAR WORK PERFORMANCE COMPARED TO FULL SILVER ELECTRODES.

THERMACUT®, FHT-EX® AND EX-TRAFIRE® ARE REGISTERED TRADEMARKS OF THERMACUT, K. S. AND MAY BE REGISTERED IN CZECH REPUBLIC AND/OR OTHER COUNTRIES. ALL OTHER TRADEMARKS ARE PROPERTIES OF THEIR RESPECTIVE OWNERS. THERMACUT IS NO WAY AFFILIATED WITH KJELLBERG®. MOST THERMACUT PARTS ARE MADE FOR OR BY AN IBG COMPANY. PARTS INDICATED WITH A OEM ARE ORIGINAL PARTS MANUFACTURED BY THE ABOVE NAMED MANUFACTURER AND ARE BEING RESOLD BY THERMACUT. THERMACUT RESERVES THE RIGHT TO SUBSTITUTE OEM PARTS IN PLACE OF THERMACUT PARTS. VALID FROM SEPTEMBER 2024 • PREVIOUS VERSION IS NO LONGER VALID. • © COPYRIGHT 2024 BY THERMACUT® CZECH REPUBLIC. ALL RIGHTS RESERVED.

**THERMACUT® REPLACEMENT PARTS SUITABLE FOR
KJELLBERG®**

FineFocus® 800 / FineFocus® 900 | PA-S75™/PB-S75™/PB-S76™/PB-S77™

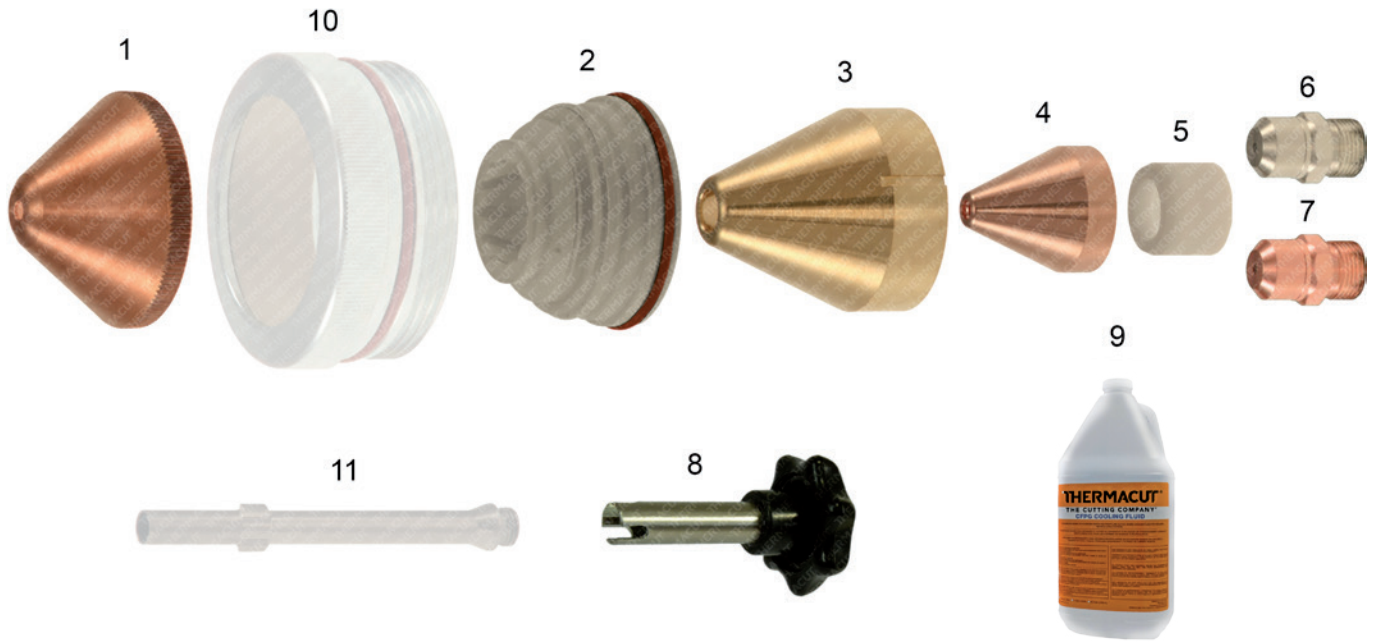

Item	Part No.	Ref. No.	Sh.Ref.No.	Description	Std. Pkg.	Item	Part No.	Ref. No.	Sh.Ref.No.	Description	Std. Pkg.
1.	T-10591	11.833.101.1550	V4330	Swirl Gas Cap 3.0	1		T-11301	11.828.901.425	L2 XL	Nozzle 250A, Air/O ₂	10
	T-10220	11.833.101.155	V4335	Swirl Gas Cap 3.5	1		T-10247	11.828.901.427	L4XL	Nozzle 300A, Air/O ₂	5
	T-10221	11.833.101.156	V4340	Swirl Gas Cap 4.0	1		T-10588	12.40850	L2	Nozzle 250A PB-S75™ WH	5
	T-10222	11.833.101.157	V4345	Swirl Gas Cap 4.5	1	5.	T-10369	12.40860		Swirl Ring, Air/O ₂ , PB-S75™	5
	T-10223	11.833.101.158	V4350	Swirl Gas Cap 5.0	1	6.	T-4932	11.828.921.300-AG	K2-XL	Cathode, O ₂ /Air, SilverEX-®, PB-S76™, PB-S75™	5
	T-10224	11.833.101.159	V4360	Swirl Gas Cap 6.0	1		T-4933	11.833.121.300-AG	K3-XL	Cathode, O ₂ /Air, SilverEX-®, PB-S77™	5
2.	N-18266	11.836.901.271	T521	Insulator	1	7.	T-10225	12.40870	K2	Cathode, Air/O ₂ , PB-S75™ WH	5
2a.	N-18371	N-18371		O-Ring	1	8.	T-10564	12.38180		Wrench for Cooling Tube	1
3.	T-10219	12.37790		Nozzle Cap PB-S75™	1	9.	Coolant Liquid. Details on the Accessories page.				
4.	T-8927	11.828.901.420	L1 XL	Nozzle 160A, Air/O ₂	10	10.-11.	Not available any more - OEM only.				

THERMACUT®, FHT-EX® AND EX-TRAFIRE® ARE REGISTERED TRADEMARKS OF THERMACUT, K. S. AND MAY BE REGISTERED IN CZECH REPUBLIC AND/OR OTHER COUNTRIES. ALL OTHER TRADEMARKS ARE PROPERTIES OF THEIR RESPECTIVE OWNERS. THERMACUT IS NO WAY AFFILIATED WITH KJELLBERG®. MOST THERMACUT PARTS ARE MADE FOR OR BY AN IBG COMPANY. PARTS INDICATED WITH A OEM ARE ORIGINAL PARTS MANUFACTURED BY THE ABOVE NAMED MANUFACTURER AND ARE BEING RESOLD BY THERMACUT. THERMACUT RESERVES THE RIGHT TO SUBSTITUTE OEM PARTS IN PLACE OF THERMACUT PARTS. VALID FROM SEPTEMBER 2024 • PREVIOUS VERSION IS NO LONGER VALID. • © COPYRIGHT 2024 BY THERMACUT® CZECH REPUBLIC. ALL RIGHTS RESERVED.

**THERMACUT® REPLACEMENT PARTS SUITABLE FOR
KJELLBERG®
FineFocus® 800 / FineFocus® 900 | PB-S80™**

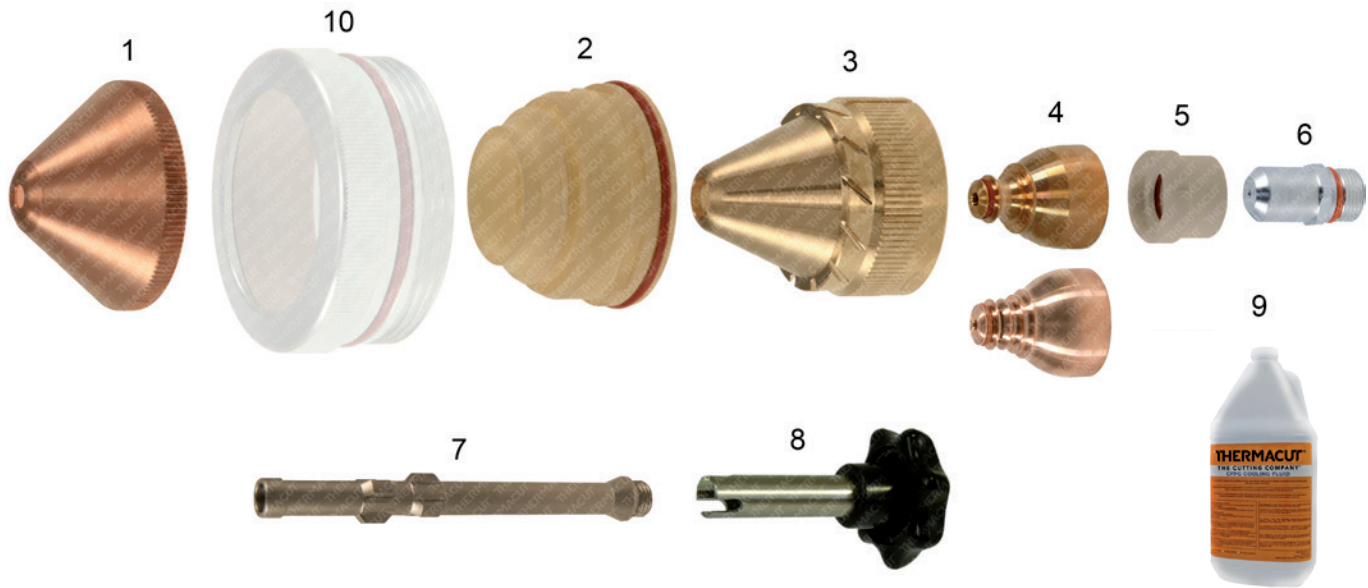

Item	Part No.	Ref. No.	Sh.Ref.No.	Description	Std. Pkg.	Item	Part No.	Ref. No.	Sh.Ref.No.	Description	Std. Pkg.
1.	T-10591	11.833.101.1550	V4330	Swirl Gas Cap 3.0	1		T-10927**	11.846.921.415-UR	T2115Y	Nozzle 120A, O ₂ , repl. 11.836.921.415	10
	T-10220	11.833.101.155	V4335	Swirl Gas Cap 3.5	1		T-10928**	11.846.921.420-UR	T2120Y	Nozzle 200A, O ₂ , repl. 11.836.921.420	10
	T-10221	11.833.101.156	V4340	Swirl Gas Cap 4.0	1		T-10929**	11.846.921.425-UR	T2125Y	Nozzle 250A, O ₂ , repl. 11.836.921.425	10
	T-10222	11.833.101.157	V4345	Swirl Gas Cap 4.5	1		T-10930**	11.846.921.427-UR	T2127Y	Nozzle 300A, O ₂ , repl. 11.836.921.427	10
	T-10223	11.833.101.158	V4350	Swirl Gas Cap 5.0	1		T-10931**	11.846.921.430-UR	T2130Y	Nozzle 360A, O ₂ , repl. 11.836.921.430	10
	T-10224	11.833.101.159	V4360	Swirl Gas Cap 6.0	1	5.	T-10466	11.836.921.1542	T104	Swirl Ring (3×0.4 CW)	1
2.	N-18267	11.836.921.271		Insulator	1		T-10672	11.836.921.153	T101	Swirl Ring (6×0.8 CW), Vespel®	1
	N-18266	11.836.901.271	T521	Insulator	1		T-10464	11.836.921.154	T102	Swirl Ring (3×0.8 CW)	1
2a.	N-18371	N-18371		O-Ring	1	OD	TN-0004	11.836.921.153	T101	Swirl Ring (6×0.8 CW), Ceramic	1
3.	T-10214	11.836.901.163	T3030	Nozzle Cap (12×1.5 30° CW)	1	6.	T-10804	11.844.921.300-AG	T012Y	Cathode, SilverEX®, use with T902Y	5
	T-10215	11.836.901.164	T3045	Nozzle Cap (12×1.5 45° CW)	1	7.	T-10467	11.828.911.230	V951	Cooling Tube PB-S77™; PB-S80™	1
OD	T-10217	11.836.901.1641	T3145	Nozzle Cap (12×1.5 45° CCW)	1		T-10558	11.844.901.152	T902Y	Cooling Tube, use with T012Y	1
	T-10216	11.836.901.165	T3060	Nozzle Cap (12×1.5 60° CW)	1	8.	T-10564	12.38180		Wrench for Cooling Tube	1
4.	T-10559	11.846.921.415	T2115Y	Nozzle 120A, O ₂ , repl. 11.836.921.415 (i)	10	9.	Coolant Liquid. Details on the Accessories page.				
	T-10560	11.846.921.420	T2120Y	Nozzle 200A, O ₂ , repl. 11.836.921.420 (i)	10	10.	Not available any more – OEM only.				
	T-10561	11.846.921.425	T2125Y	Nozzle 250A, O ₂ , repl. 11.836.921.425 (i)	10						
	T-10562	11.846.921.427	T2127Y	Nozzle 300A, O ₂ , repl. 11.836.921.427 (i)	10						
	T-10563	11.846.921.430	T2130Y	Nozzle 360A, O ₂ , repl. 11.836.921.430 (i)	10						

OD ON DEMAND – WE DO NOT KEEP THESE PARTS IN STOCK, COST IS SET ACCORDING TO THE ORDERED QUANTITY, DELIVERY TIME MAY DIFFER FROM STANDARD PRODUCTS.

(i) THIS PART MAY NOT BE DISTRIBUTED ON THE GERMAN, ITALIAN, FRENCH AND GREAT BRITAIN MARKET. THERMACUT® ACCEPTS NO RESPONSIBILITY IN CASE OF INDIRECT SALES TO GERMANY, ITALY, FRANCE AND GREAT BRITAIN.

****** A UNIQUE DESIGN WHICH ENHANCES PERFORMANCE AND DIFFERS FROM OEM DESIGNS

CCW COUNTER CLOCK WISE GAS SWIRLING, USE OF CCW PARTS WILL MAKE CUT ANGLE ON THE OPPOSITE SIDE, THAN WITH STANDARD CLOCK WISE (CW) SWIRLING PARTS.

THERMACUT®, FHT-EX® AND EX-TRAFIRE® ARE REGISTERED TRADEMARKS OF THERMACUT, K. S. AND MAY BE REGISTERED IN CZECH REPUBLIC AND/OR OTHER COUNTRIES. ALL OTHER TRADEMARKS ARE PROPERTIES OF THEIR RESPECTIVE OWNERS. THERMACUT IS NO WAY AFFILIATED WITH KJELLBERG®. MOST THERMACUT PARTS ARE MADE FOR OR BY AN IBG COMPANY. PARTS INDICATED WITH A OEM ARE ORIGINAL PARTS MANUFACTURED BY THE ABOVE NAMED MANUFACTURER AND ARE BEING RESOLD BY THERMACUT. THERMACUT RESERVES THE RIGHT TO SUBSTITUTE OEM PARTS IN PLACE OF THERMACUT PARTS.
VALID FROM SEPTEMBER 2024 • PREVIOUS VERSION IS NO LONGER VALID. • © COPYRIGHT 2024 BY THERMACUT® CZECH REPUBLIC. ALL RIGHTS RESERVED.

**THERMACUT® REPLACEMENT PARTS SUITABLE FOR
KOMATSU®
G990™, G9120™ TORCH, 90A | RASOR® KCR-1251, 12714, 9714, 0951**

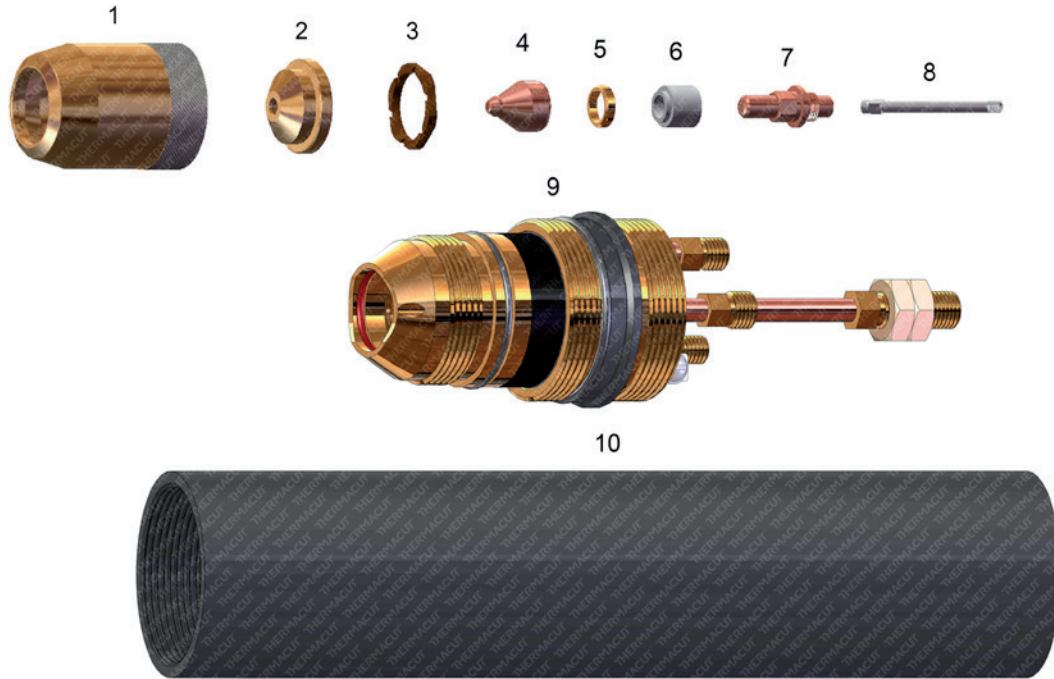

Item	Part No.	Ref. No.	Description	Std. Pkg	Item	Part No.	Ref. No.	Description	Std. Pkg
1.	T-2057	65-0434-016	Cap #2	1	OD 6.	T-2061	65-0434-020	Guide	1
OD 2.	T-4097	65-0442-005	Shield Cap	1	7.	T-2321	65-0442-001	Electrode	5
OD 3.	T-2359	65-0442-004	Spacer Ring	1	8.	T-3421	65-0442-009	Cooling Tube 120A	1
4.	T-2058	65-0434-017	Nozzle 0.8mm	5	9.	T-8818	7848-65-5620	Torch Body	1
	T-2353	65-0442-002	Nozzle 1.3mm	5	OD 10.	T-11198	969-94-61310	Tube	1
5.	T-9595	65-0434-018	Swirl Ring	2	NS	KT-1414		G990™ Cable Leads 10m (33')	1

OD ON DEMAND – WE DO NOT KEEP THESE PARTS IN STOCK, COST IS SET ACCORDING TO THE ORDERED QUANTITY, DELIVERY TIME MAY DIFFER FROM STANDARD PRODUCTS.

NS NOT SHOWN IN THE PICTURE

THERMACUT®, FHT-EX® AND EX-TRAFIRE® ARE REGISTERED TRADEMARKS OF THERMACUT, K. S. AND MAY BE REGISTERED IN CZECH REPUBLIC AND/OR OTHER COUNTRIES. ALL OTHER TRADEMARKS ARE PROPERTIES OF THEIR RESPECTIVE OWNERS. THERMACUT IS NO WAY AFFILIATED WITH KOMATSU®. MOST THERMACUT PARTS ARE MADE FOR OR BY AN IBG COMPANY. PARTS INDICATED WITH A OEM ARE ORIGINAL PARTS MANUFACTURED BY THE ABOVE NAMED MANUFACTURER AND ARE BEING RESOLD BY THERMACUT. THERMACUT RESERVES THE RIGHT TO SUBSTITUTE OEM PARTS IN PLACE OF THERMACUT PARTS. VALID FROM SEPTEMBER 2024 • PREVIOUS VERSION IS NO LONGER VALID. • © COPYRIGHT 2024 BY THERMACUT® CZECH REPUBLIC. ALL RIGHTS RESERVED.

**THERMACUT® REPLACEMENT PARTS SUITABLE FOR
LINCOLN ELECTRIC® TH1538
APPLICATION OF DURAMAX® TORCH TO TOMAHAWK® 1538 CUTTING SYSTEM**

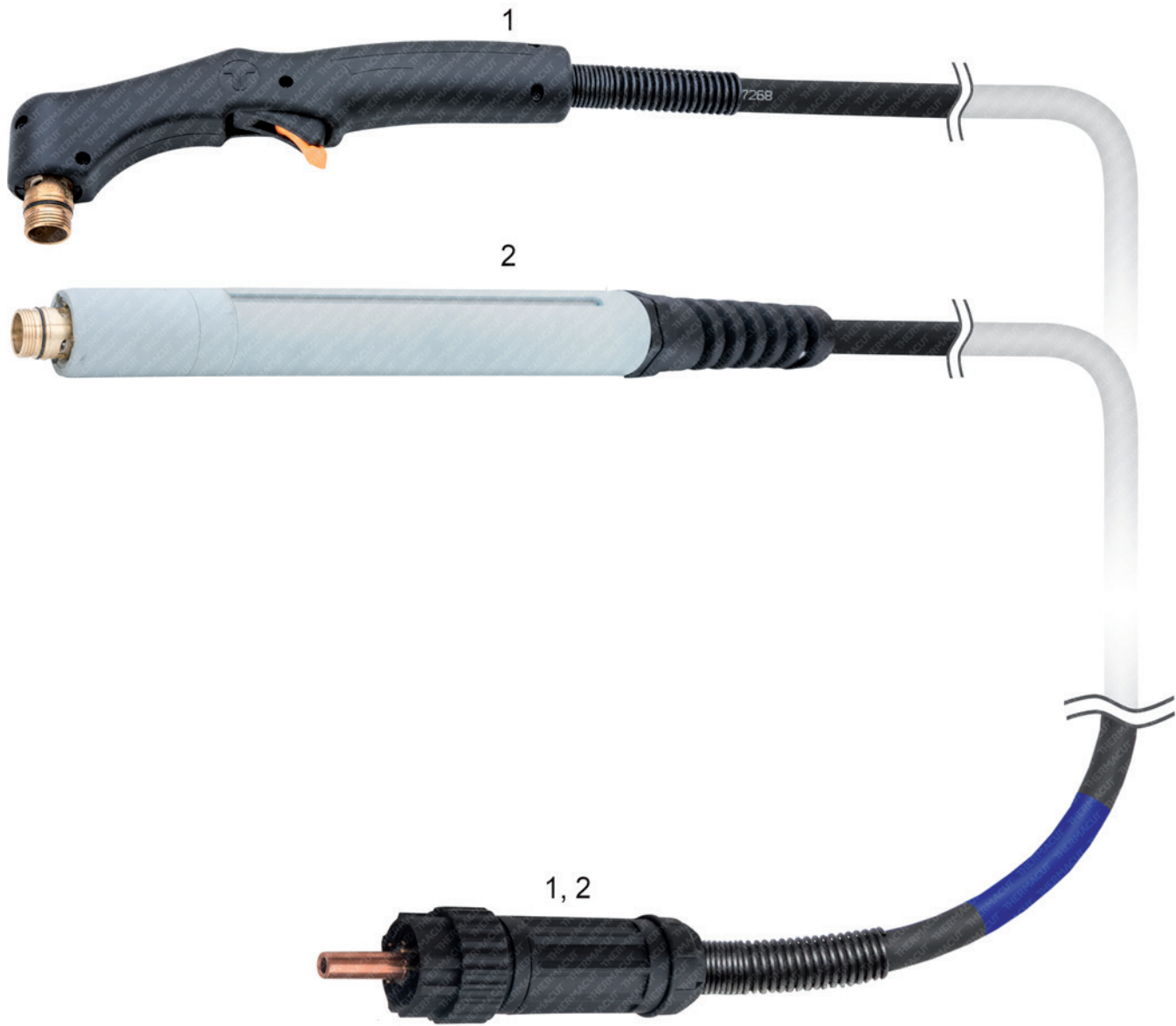

List of consumables and spare parts is available in section POWERMAX® 65/85/105

Item	Part No.	Description
1.	T-13184	DURAMAX® Hand Torch with Leads 8m (26,25') for Lincoln Electric® TH1538
2.	T-13185	DURAMAX® Machine Torch with Leads, length 8m without Rack; for Lincoln Electric® TH1538

THERMACUT®, FHT-EX® AND EX-TRAFIRE® ARE REGISTERED TRADEMARKS OF THERMACUT, K. S. AND MAY BE REGISTERED IN CZECH REPUBLIC AND/OR OTHER COUNTRIES. ALL OTHER TRADEMARKS ARE PROPERTIES OF THEIR RESPECTIVE OWNERS. THERMACUT IS NO WAY AFFILIATED WITH LINCOLN ELECTRIC®. MOST THERMACUT PARTS ARE MADE FOR OR BY AN IBG COMPANY. PARTS INDICATED WITH A OEM ARE ORIGINAL PARTS MANUFACTURED BY THE ABOVE NAMED MANUFACTURER AND ARE BEING RESOLD BY THERMACUT. THERMACUT RESERVES THE RIGHT TO SUBSTITUTE OEM PARTS IN PLACE OF THERMACUT PARTS. VALID FROM SEPTEMBER 2024 • PREVIOUS VERSION IS NO LONGER VALID. • © COPYRIGHT 2024 BY THERMACUT® CZECH REPUBLIC. ALL RIGHTS RESERVED.

**THERMACUT® REPLACEMENT PARTS SUITABLE FOR
LINCOLN ELECTRIC®
PRO-CUT® 25/55/80 | PCT20/80**

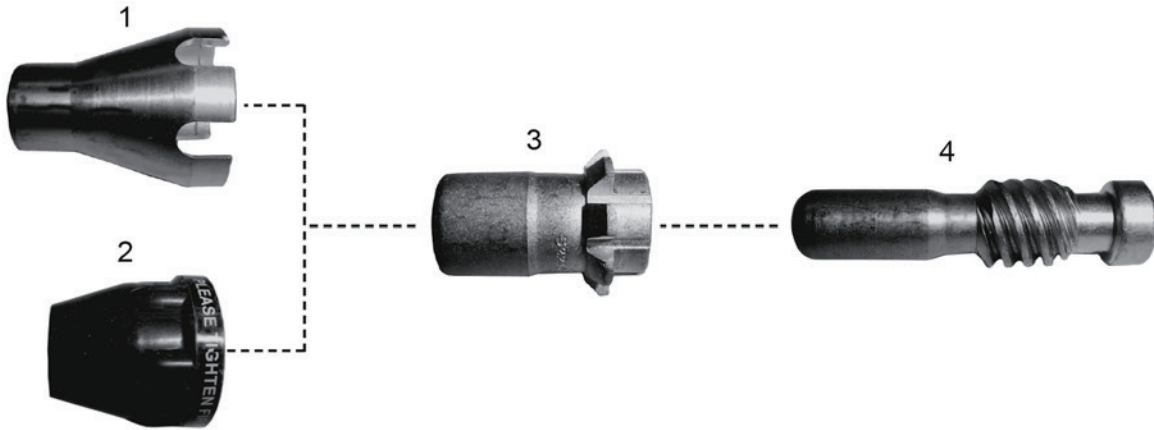

Item	Part No.	Ref. No.	Description	System	Std. Pkg.	Item	Part No.	Ref. No.	Description	System	Std. Pkg.
1.	T-2960	KP2065-1 OEM	Drag Cup	25, 55, 80	1		T-2980	KP2062-4B1 OEM	Nozzle, Gouging, .068	55, 80	5
2.	T-11538	KP2064-1 OEM	Shield Cup	25, 55, 80	1		T-4194	KP2062-5B1 OEM	Nozzle, Gouging, .082	80	5
3.	T-3536	KP2062-1B1 OEM	Nozzle .028	25	5	4.	T-11536	KP2063-1B1	Electrode	25, 55, 80	5
	T-11537	KP2062-2B1 OEM	Nozzle .043	55, 80	5						

THERMACUT®, FHT-EX® AND EX-TRAFIRE® ARE REGISTERED TRADEMARKS OF THERMACUT, K. S. AND MAY BE REGISTERED IN CZECH REPUBLIC AND/OR OTHER COUNTRIES. ALL OTHER TRADEMARKS ARE PROPERTIES OF THEIR RESPECTIVE OWNERS. THERMACUT IS NO WAY AFFILIATED WITH LINCOLN ELECTRIC®. MOST THERMACUT PARTS ARE MADE FOR OR BY AN IBG COMPANY. PARTS INDICATED WITH A OEM ARE ORIGINAL PARTS MANUFACTURED BY THE ABOVE NAMED MANUFACTURER AND ARE BEING RESOLD BY THERMACUT. THERMACUT RESERVES THE RIGHT TO SUBSTITUTE OEM PARTS IN PLACE OF THERMACUT PARTS.
VALID FROM SEPTEMBER 2024 • PREVIOUS VERSION IS NO LONGER VALID. • © COPYRIGHT 2024 BY THERMACUT® CZECH REPUBLIC. ALL RIGHTS RESERVED.

THERMACUT® REPLACEMENT PARTS SUITABLE FOR Thermal Dynamics® PCH-10 TORCH

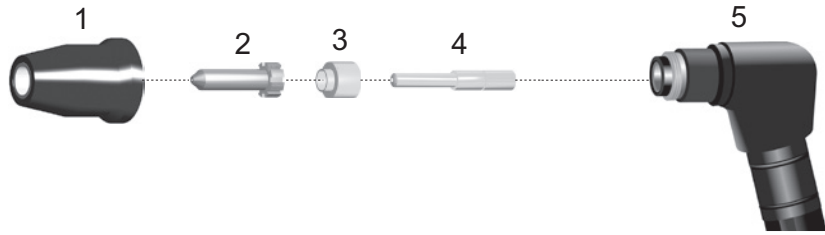

Torch body features
our patented design
US Patent #6,271,497

Item	Part No.	Ref. No.	Description	Std. Pkg.	Item	Part No.	Ref. No.	Description	Std. Pkg.
1.	T-0272	9-6003	Shield Cup	1	4.	T-0103	9-6006	Electrode	10
2.	T-2307	9-6099	Tip, 12 Amp	10	5.	T-0267**	9-5807DURA	Hand DURA Torch 70°	1
3.	T-0269	9-6007	Gas Distributor	5					

THERMACUT® REPLACEMENT PARTS SUITABLE FOR PCH-25/38 TORCH

Item	Part No.	Ref. No.	Description	Std. Pkg.	Item	Part No.	Ref. No.	Description	Std. Pkg.
1.	T-0272	9-6003	Shield Cup	1		T-1332	9-6507	Gas Distributor, Long Life	5
2.	T-1334	9-4476	Tip, Cutting	10	4.	T-0103	9-6006	Electrode, Air	10
	T-1331	9-6501	Tip, Drag, Long Life	10		T-1333	9-6506	Electrode, Air, Long Life	10
3.	T-0269	9-6007	Gas Distributor	5	5.	T-0267**	9-5807 DURA	Hand Torch (70)	1

THERMACUT® REPLACEMENT PARTS SUITABLE FOR PCH/M28, PCH-26

Item	Part No.	Ref. No.	Description	Std. Pkg.	Item	Part No.	Ref. No.	Description	Std. Pkg.
1.	T-0272	9-6003	Shield Cup	1	3.	T-0269	9-6007	Gas Distributor	5
	T-1328	9-6503	Shield Cup, Long Life	1		T-1332	9-6507	Gas Distributor, Long Life	5
2.	T-0270	9-6000	Tip	10	4.	T-0103	9-6006	Electrode	10
	T-0271	9-6001	Tip, Drag	10		T-1333	9-6506	Electrode, Long Life	10
	T-1329	9-6120	Tip, HD	10	5.	T-0267**	9-5807DURA	Hand DURA Torch 70°	1
	T-1330	9-6500	Tip, Stand Off, LongLife	10		T-1075	9-5808	Hand Torch 90°	1
	T-1331	9-6501	Tip, Drag, LongLife	10					

NOTE: PCH/M-28 USES ONLY "LONGLIFE" CONSUMABLES.

THERMACUT® REPLACEMENT PARTS SUITABLE FOR PCH/M-35, PCH/M-40

Item	Part No.	Ref. No.	Description	Std. Pkg.	Item	Part No.	Ref. No.	Description	Std. Pkg.
1.	T-0272	9-6003	Shield Cup	1	3.	T-0269	9-6007	Gas Distributor	5
	T-1328	9-6503	Shield Cup, Long Life	1		T-1332	9-6507	Gas Distributor, Long Life	5
2.	T-0270	9-6000	Tip	10	4.	T-0103	9-6006	Electrode	10
	T-1074	9-6001	Tip, Drag	10		T-1333	9-6506	Electrode, Long Life	10
	T-1330	9-6120	Tip, HD	10	5.	T-1075	9-5808	Hand Torch 90°	1
	T-1331	9-6500	Tip, Stand Off, Long Life	10		T-0267**	9-5807DURA	Hand Dura Torch, 70°	1
	T1331	9-6501	Tip, Drag, Long Life	10					

** A UNIQUE DESIGN WHICH ENHANCES PERFORMANCE AND DIFFERS FROM OEM DESIGNS

THERMACUT®, FHT-EX® AND EX-TRAFIRE® ARE REGISTERED TRADEMARKS OF THERMACUT, K. S. AND MAY BE REGISTERED IN CZECH REPUBLIC AND/OR OTHER COUNTRIES. ALL OTHER TRADEMARKS ARE PROPERTIES OF THEIR RESPECTIVE OWNERS. THERMACUT IS NO WAY AFFILIATED WITH Thermal Dynamics®. MOST THERMACUT PARTS ARE MADE FOR OR BY AN IBG COMPANY. PARTS INDICATED WITH A OEM ARE ORIGINAL PARTS MANUFACTURED BY THE ABOVE NAMED MANUFACTURER AND ARE BEING RESOLD BY THERMACUT. THERMACUT RESERVES THE RIGHT TO SUBSTITUTE OEM PARTS IN PLACE OF THERMACUT PARTS. VALID FROM SEPTEMBER 2024 • PREVIOUS VERSION IS NO LONGER VALID. • © COPYRIGHT 2024 BY THERMACUT® CZECH REPUBLIC. ALL RIGHTS RESERVED.

THERMACUT® REPLACEMENT PARTS SUITABLE FOR
Thermal Dynamics®
PCH/M-75, PCH/M-76

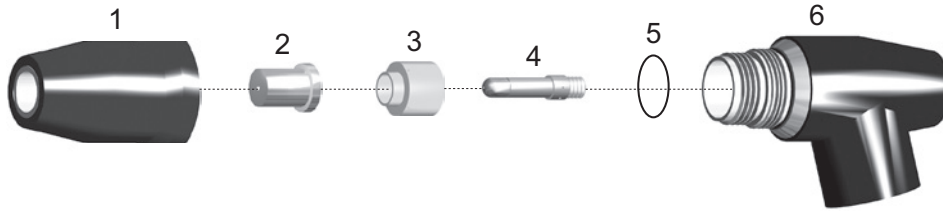

Item	Part No.	Ref. No.	Description	Std. Pkg.	Item	Part No.	Ref. No.	Description	Std. Pkg.
1.	T-1609	8-7500	Shield Cap	1		T-1708	8-7506	Gouging Tip	5
	T-1706	8-7507 OEM	Crown Shield Cup	1	3.	T-1611	8-7501	Gas Distributor	5
2.	T-1610	8-7504	Tip, 55 Amp	5		T-1709	8-7508	Gouging Gas Distributor	2
	T-2535	9-7726	Tip, 60 Amp	5	4.	T-1612	8-7502	Electrode	5
	T-2534	9-7728	Tip, 80 Amp	5	5.	T-1615	8-0532	O-Ring	1
	T-2126	8-7505	Tip, 70 Amp	5	OD 6.	T-1613	8-7510	Torch Body 70°	1
	T-1707	8-7503	Drag Tip, 35 Amp	5					

ACCESSORIES

Hand Torch



Machine Torch

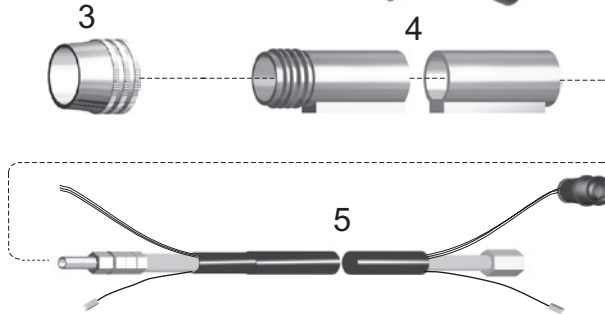

Item	Part No.	Ref. No.	Description	Std. Pkg.	Item	Part No.	Ref. No.	Description	Std. Pkg.
1.	T-0155	8-1322	Retaining Sheath	1	NS	T-2897	2-0002	100XL Torch 70° with 50' Leads	1
2.	T-1040	9-5636-1	Handle with Switch	1	NS	T-2890	2-7501	75 Torch, 70° with 25' Leads	1
3.	T-0157	8-4018	Nut	1	NS	T-2891	2-7502	75 Torch, 70° with 50' Leads	1
4.	T-0159	8-5005	Mounting Tube	1	NS	T-2919	4-7611	25' Leads	1
5.	T-1711	4-7500	Hand Leads, NonShielded, 25'	1	NS	T-2920	4-7612	50' Leads	1
	T-1712	4-7501	Hand Leads, NonShielded, 50'	1	NS	T-0160	7-2827 OEM	Pinion Assembly	1
	T-0759	4-0010	Hand Leads, 100XL, NonShielded, 25'	1	NS	T-0874	9-5636 OEM	Handle	1
NS	T-1713	4-7502	Machine Leads, NonShielded, 25'	1					
NS	T-1714	4-7503	Machine Leads, NonShielded, 50'	1					
NS	T-2896	2-0001	100XL Torch 70° with 25' Leads	1					

VERIFY POWER SUPPLY WHEN ORDERING LEADS

OD ON DEMAND – WE DO NOT KEEP THESE PARTS IN STOCK, COST IS SET ACCORDING TO THE ORDERED QUANTITY, DELIVERY TIME MAY DIFFER FROM STANDARD PRODUCTS.

NS NOT SHOWN IN THE PICTURE

THERMACUT®, FHT-EX® AND EX-TRAFIRE® ARE REGISTERED TRADEMARKS OF THERMACUT, K. S. AND MAY BE REGISTERED IN CZECH REPUBLIC AND/OR OTHER COUNTRIES. ALL OTHER TRADEMARKS ARE PROPERTIES OF THEIR RESPECTIVE OWNERS. THERMACUT IS NO WAY AFFILIATED WITH Thermal Dynamics®. MOST THERMACUT PARTS ARE MADE FOR OR BY AN IBC COMPANY. PARTS INDICATED WITH A OEM ARE ORIGINAL PARTS MANUFACTURED BY THE ABOVE NAMED MANUFACTURER AND ARE BEING RESOLD BY THERMACUT. THERMACUT RESERVES THE RIGHT TO SUBSTITUTE OEM PARTS IN PLACE OF THERMACUT PARTS. VALID FROM SEPTEMBER 2024 • PREVIOUS VERSION IS NO LONGER VALID. • © COPYRIGHT 2024 BY THERMACUT® CZECH REPUBLIC. ALL RIGHTS RESERVED.

THERMACUT® REPLACEMENT PARTS SUITABLE FOR Thermal Dynamics® PCH-42

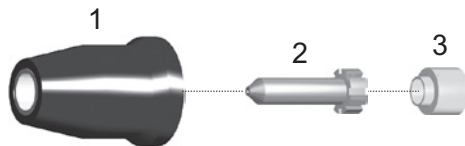

Item	Part No.	Ref. No.	Description	Std. Pkg.	Item	Part No.	Ref. No.	Description	Std. Pkg.
1.	T-0272	9-6003	Shield Cup	1		T-1331	9-6501	Drag Tip	10
	T-1328	9-6503	Shield Cup, Long Life	1	3.	T-1332	9-6507	Gas Distributor	5
2.	T-1330	9-6500	Standoff Tip	10					

THERMACUT® REPLACEMENT PARTS SUITABLE FOR PCH-62

Item	Part No.	Ref. No.	Description	Std. Pkg.	Item	Part No.	Ref. No.	Description	Std. Pkg.
1.	T-12420	9-8400 OEM	Shield Cup	1	3.	T-2877	9-8401	Gas Distributor	1
	T-2924	9-8415 OEM	Torch Stand-off Guide	1	4.	T-3721	9-8407 OEM	Electrode	5
2.	T-2880	9-8411	Tip	10		T-3720	9-8402 OEM	Electrode	5
	T-3317	9-8412	Stand Off Tip	10					

THERMACUT® REPLACEMENT PARTS SUITABLE FOR PCH-102

Item	Part No.	Ref. No.	Description	Std. Pkg.	Item	Part No.	Ref. No.	Description	Std. Pkg.
1.	T-1609	8-7500	Shield Cap	1		T-1708	8-7506	Gouging Tip	5
	T-1706	8-7507	Castle Shield Cap	1	3.	T-1611	8-7501	Gas Distributor	5
2.	T-1707	8-7503	Drag Tip	5		T-1709	8-7508	Gouging Gas Distributor	2
	T-2535	9-7726	Tip 60 Amp	5	4.	T-3721	9-8407 OEM	Electrode	5
	T-2126	8-7505	Tip 70 Amp	5		T-3720	9-8402 OEM	Electrode	5
	T-2534	9-7728	Tip 80 Amp	5					

THERMACUT® REPLACEMENT PARTS SUITABLE FOR 1Torch®

Item	Part No.	Ref. No.	Description	Std. Pkg.	Item	Part No.	Ref. No.	Description	Std. Pkg.
NS	T-10656	9-8215 OEM	Electrode ML	5	NS	T-10642	9-8206 OEM	Tip, 30A, Drag	5
NS	T-10666	9-8224 OEM	Ohmic Clip	1	NS	T-10644	9-8208 OEM	Tip, 40A, Cutting	5
NS	T-10661	9-8218 OEM	Shield Cup	1	NS	T-10643	9-8207 OEM	Tip, 40A, Drag	5
NS	T-10415	9-8237 OEM	Shield Cup Body ML	1	NS	T-10645	9-8209 OEM	Tip, 50/55A, Cutting	5
NS	T-10666	9-8244 OEM	Shield Cup, Drag 40A	1	NS	T-10660	9-8210 OEM	Tip, 60A, Cutting	5
NS	T-10652	9-8235 OEM	Shield Cup, Drag 50/60A	1	NS	T-10659	9-8231 OEM	Tip, 70A, Cutting	5
NS	T-10653	9-8236 OEM	Shield Cup, Drag 70/100A	1	NS	T-10658	9-8211 OEM	Tip, 80A, Cutting	5
NS	T-10665	9-8245 OEM	Shield Cup, Machine, 40A	1	NS	T-10657	9-8212 OEM	Tip, 90/100A, Cutting	5
NS	T-10654	9-8238 OEM	Shield Cup, Machine, 50/60A	1	NS	T-10646	9-8225 OEM	Tip, A, Gouging	5
NS	T-10655	9-8239 OEM	Shield Cup, Machine, 70/100A	1	NS	T-10647	9-8226 OEM	Tip, B, Gouging	5
NS	T-10650	9-8243 OEM	Shield Cup, Machine, Deflector	1	NS	T-10658	9-8227 OEM	Tip, C, Gouging	5
NS	T-10651	9-8241 OEM	Shield Cup, Machine, Gouging	1	NS	T-10649	9-8228 OEM	Tip, D, Gouging	5
NS	T-10663	9-8213 OEM	Start Cartridge	1					
NS	T-10641	9-8205 OEM	Tip, 20A, Drag	5					

NS NOT SHOWN IN THE PICTURE

THERMACUT®, FHT-EX® AND EX-TRAFIRE® ARE REGISTERED TRADEMARKS OF THERMACUT, K. S. AND MAY BE REGISTERED IN CZECH REPUBLIC AND/OR OTHER COUNTRIES. ALL OTHER TRADEMARKS ARE PROPERTIES OF THEIR RESPECTIVE OWNERS. THERMACUT IS NO WAY AFFILIATED WITH Thermal Dynamics®. MOST THERMACUT PARTS ARE MADE FOR OR BY AN IBG COMPANY. PARTS INDICATED WITH A OEM ARE ORIGINAL PARTS MANUFACTURED BY THE ABOVE NAMED MANUFACTURER AND ARE BEING RESOLD BY THERMACUT. THERMACUT RESERVES THE RIGHT TO SUBSTITUTE OEM PARTS IN PLACE OF THERMACUT PARTS. VALID FROM SEPTEMBER 2024 • PREVIOUS VERSION IS NO LONGER VALID. • © COPYRIGHT 2024 BY THERMACUT® CZECH REPUBLIC. ALL RIGHTS RESERVED.

THERMACUT® REPLACEMENT PARTS SUITABLE FOR Thermal Dynamics® PCH/M-51

Part No.	Ref. No.	Description	Std. Pkg	Part No.	Ref. No.	Description	Std. Pkg
T-0148	9-5631	Tip .043	10	T-0152	9-5635	TMT-51, Hand Torch	1
T-0150	9-5633	Electrode	10				

THERMACUT® REPLACEMENT PARTS SUITABLE FOR PCH/M-52

Part No.	Ref. No.	Description	Std. Pkg	Part No.	Ref. No.	Description	Std. Pkg
T-0166	9-5617	Shield Cup	10	T-0173	9-5702	Tip, .031, 35 Amp	10
T-0168	9-5694	Crown Shield Cup	10	T-0173	9-5702	Tip, .031, 35 Amp	10
T-0169	9-5694-1	Crown Shield Cup, SR	1	T-0176	9-5619	Electrode, Air	10
T-0170	9-5708	Tip, .059, 100 Amp	10	T-1021	8-3331	Electrode, Air	10
T-0171	9-5707	Tip, .047, 70 Amp	10	T-0151	8-5525	O-Ring	10
T-0172	9-5618	Tip, .043, 45 Amp	10	T-0163	8-4025	Lubricant	1

THERMACUT® REPLACEMENT PARTS SUITABLE FOR PCH/M-150 TORCH

Item	Part No.	Ref. No.	Description	Std. Pkg.	Item	Part No.	Ref. No.	Description	Std. Pkg.
NS	T-1032	9-5750-1	Ceramic Taper Piece	1	OD NS	T-0247	9-5767	Tip .067 150A, Nit	5
OD NS	T-0241	9-5746	Tip .070 150A, Air	5	OD NS	T-0253	9-5749	Electrode, Air	5
OD NS	T-0242	9-5747	Tip .055 100A, Air	5	OD NS	T-0255	9-5760	Electrode, Oxy	5
OD NS	T-0243	9-5748	Tip .043 50A, Air	5	OD NS	T-0256	9-5743	TMT-150 Hand Torch 70°	1

OD ON DEMAND – WE DO NOT KEEP THESE PARTS IN STOCK, COST IS SET ACCORDING TO THE ORDERED QUANTITY, DELIVERY TIME MAY DIFFER FROM STANDARD PRODUCTS.

NS NOT SHOWN IN THE PICTURE

THERMACUT®, FHT-EX® AND EX-TRAFIRE® ARE REGISTERED TRADEMARKS OF THERMACUT, K. S. AND MAY BE REGISTERED IN CZECH REPUBLIC AND/OR OTHER COUNTRIES. ALL OTHER TRADEMARKS ARE PROPERTIES OF THEIR RESPECTIVE OWNERS. THERMACUT IS NO WAY AFFILIATED WITH Thermal Dynamics®. MOST THERMACUT PARTS ARE MADE FOR OR BY AN IBG COMPANY. PARTS INDICATED WITH A OEM ARE ORIGINAL PARTS MANUFACTURED BY THE ABOVE NAMED MANUFACTURER AND ARE BEING RESOLD BY THERMACUT. THERMACUT RESERVES THE RIGHT TO SUBSTITUTE OEM PARTS IN PLACE OF THERMACUT PARTS.
VALID FROM SEPTEMBER 2024 • PREVIOUS VERSION IS NO LONGER VALID. • © COPYRIGHT 2024 BY THERMACUT® CZECH REPUBLIC. ALL RIGHTS RESERVED.

THERMACUT® REPLACEMENT PARTS SUITABLE FOR Thermal Dynamics® PCH/M-6B

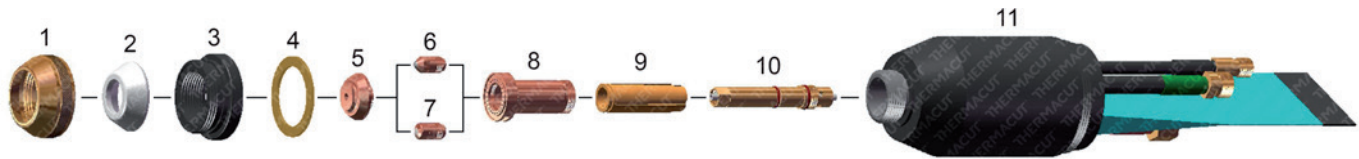

Item	Part No.	Ref. No.	Description	Std. Pkg.	Item	Part No.	Ref. No.	Description	Std. Pkg.
1.	T-0233	8-6515	End Cap	1		T-0216	8-6584	6B Hand Torch 90°	1
2.	T-0232	8-6514	Insulator, End Piece	5	NS	T-0159	8-5005	Positioning Tube	1
3.	T-0231	8-6581	Outer Insulator	1	NS	T-0161	8-4204	Bushing	1
4.	T-0230	8-6512	Gasket, Outer Insulator	5	NS	KT-1337	2-2747	PCH-6B 70° Torch with Leads 50' (15.2m), PAK®45	1
5.	T-0229	8-6572	Tip .125 400A	5	NS	KT-1431	2-2789	PCH-6B 70° Torch with Leads 50' (15.2m), PAK®44	1
	T-0228	8-6582	Tip .113 300A	5	NS	KT-1215	2-2790	PCH-6B® 90° Torch with Leads 25' (7.6m)	1
	T-0227	8-6575	Tip .093 200A	5	NS	T-13077	2-2791	PCH-6B® 90° Torch with Leads 50' (15.2m)	1
6.	T-0224	8-6586	Electrode, N ₂ , Metal Seat, L-Amp	10	NS	KT-1323	4-2725	PCH-6B® Cable Leads 25' (7.6m)	1
7.	T-0223	8-6578	Electrode, N ₂ , Gen. Purpose	10	NS	KT-1324	2-2792	PCM-6B® 180° Torch with Leads 25' (7.6m)	1
8.	T-0222	8-6571	Liner Assy	1	NS	KT-1188	4-2726	PCH-6B® Cable Leads 50' (15.2m)	1
9.	T-0220	8-6569	Gas Distributor, 6B, 4 Holes	1	NS	KT-1198	2-2749	PCM-6B® 180° Torch with Leads 50' (15.2m)	1
10.	T-0219	8-6615	Electrode Holder	1	NS	KT-1443	9-2866	Plasma Hose 25' (7.6m)	1
11.	T-0217	8-6577	6B Machine Torch	1	NS	KT-1444	9-2950	Power Hose 25' (7.6m)	1
	T-1423	8-6583	6B Hand Torch 70°	1					

NS NOT SHOWN IN THE PICTURE

THERMACUT®, FHT-EX® AND EX-TRAFIRE® ARE REGISTERED TRADEMARKS OF THERMACUT, K. S. AND MAY BE REGISTERED IN CZECH REPUBLIC AND/OR OTHER COUNTRIES. ALL OTHER TRADEMARKS ARE PROPERTIES OF THEIR RESPECTIVE OWNERS. THERMACUT IS NO WAY AFFILIATED WITH Thermal Dynamics®. MOST THERMACUT PARTS ARE MADE FOR OR BY AN IBG COMPANY. PARTS INDICATED WITH A OEM ARE ORIGINAL PARTS MANUFACTURED BY THE ABOVE NAMED MANUFACTURER AND ARE BEING RESOLD BY THERMACUT. THERMACUT RESERVES THE RIGHT TO SUBSTITUTE OEM PARTS IN PLACE OF THERMACUT PARTS. VALID FROM SEPTEMBER 2024 • PREVIOUS VERSION IS NO LONGER VALID. • © COPYRIGHT 2024 BY THERMACUT® CZECH REPUBLIC. ALL RIGHTS RESERVED.

THERMACUT® REPLACEMENT PARTS SUITABLE FOR
Thermal Dynamics®
PCH/M-6B ACCESSORIES

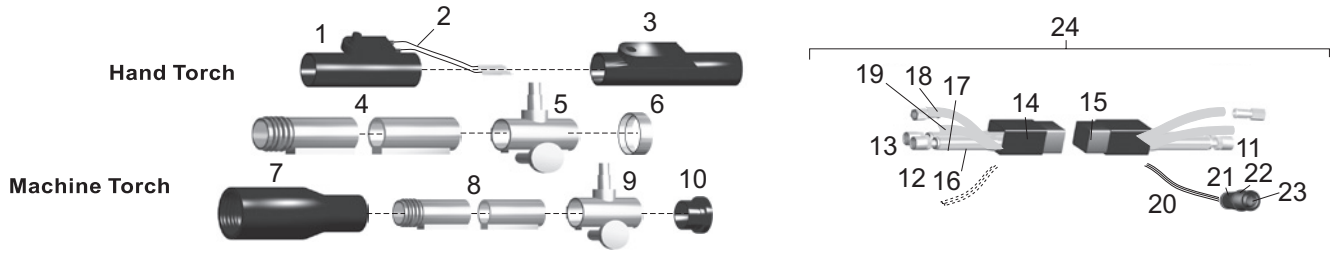

Item	Part No.	Ref. No.	Description	Std. Pkg	Item	Part No.	Ref. No.	Description	Std. Pkg
1.	T-0977	8-6519 OEM	Handle	1		T-0987	9-2867	Plasma (Black) Hose, 50'	1
2.	T-0946	8-4219	Switch	1	20.	T-1071	8-0002	Control Cable, 25'	1
3.	T-0945	8-4217 OEM	Switch Sheath	1		T-1072	8-0003	Control Cable, 50'	1
4.	T-0978	8-6521 OEM	Mounting Tube, 2 1/4" Dia	1	21.	T-1067	9-3295	Cable Clamp	1
5.	T-0936	7-2828 OEM	Pinion Assy, 2 1/4" Dia	1	22.	T-0864	9-3294	Plug	1
6.	T-0979	8-6522 OEM	Bushing	1	23.	T-0865	9-3296	Pin	1
7.	T-0980	8-6566 OEM	Adaptor, 1 3/8" Dia	1	24.	T-0932	4-2797	Hand Leads, 25'	1
8.	T-0159	8-5005	Mounting Tube, 1 3/8" Dia	1		T-0933	4-2799	Hand Leads, 50'	1
9.	T-0160	7-2827 OEM	Pinion Assy, 1 3/8" Dia	1		T-0934	4-2725	Machine Leads, 25'	1
10.	T-0161	8-4204	Bushing	1		T-0395	4-2726	Machine Leads, 50'	1
11.	T-0924	8-7033	Fitting, Console End (+, -)	1	NS	T-0981	8-6614 OEM	Heat Shield, Machine	5
12.	T-0983	8-7031	Fitting, Torch End (+)	1	NS	T-0982	8-7042 OEM	Heat Shield, Hand	1
	T-0976	8-5085	Ferrule	5	NS	T-2902	2-2744	Hand Torch 70° w/ 25' Leads	1
13.	T-0944	8-4190	Fitting, Torch End (-)	1	NS	T-2903	2-2747	Hand Torch 70° w/ 50' Leads	1
14.	T-0912	8-1205	Shrink-on, Tubing	1	NS	T-2981	2-2789	Hand Torch 70° w/ 50' Leads	1
15.	T-0940	8-1000	Leads Sleeving, 25'	1	NS	T-3404	2-2791	Hand Torch 90° w/ 50' Leads	1
	T-0985	8-7051	Leads Sleeving, 50'	1	NS	T-1907	2-2745	Hand Torch 90° w/ 25' Leads	1
16.	T-0990	9-2950	Negative (Green) Lead, 25'	1	NS	T-1905	2-2748	Hand Torch 90° w/ 50' Leads	1
	T-0991	9-2951	Negative (Green) Lead, 50'	1	NS	T-1906	2-2749	Machine Torch w/ 50' Leads	1
17.	T-0988	9-2948	Positive (Blue) Lead, 25'	1	NS	T-1908	2-2792	Machine Torch w/ Leads 25'	1
	T-0989	9-2949	Positive (Blue) Lead, 50'	1	NS	T-1909	2-2793	Machine Torch w/ Leads 50'	1
18.	T-0941	8-1009	Secondary (Yellow) Lead, 25'	1	NS	T-4033	2-2741	Machine Torch w/ Parts & Mounting Tube	1
	T-0942	8-1056	Secondary (Yellow) Lead, 50'	1	NS	T-2121	8-6564 OEM	Switch Sheath	1
19.	T-0986	9-2866	Plasma (Black) Hose, 25'	1					

NS NOT SHOWN IN THE PICTURE
W/ WITH

THERMACUT®, FHT-EX® AND EX-TRAFIRE® ARE REGISTERED TRADEMARKS OF THERMACUT, K. S. AND MAY BE REGISTERED IN CZECH REPUBLIC AND/OR OTHER COUNTRIES. ALL OTHER TRADEMARKS ARE PROPERTIES OF THEIR RESPECTIVE OWNERS. THERMACUT IS NO WAY AFFILIATED WITH Thermal Dynamics®. MOST THERMACUT PARTS ARE MADE FOR OR BY AN IBG COMPANY. PARTS INDICATED WITH A OEM ARE ORIGINAL PARTS MANUFACTURED BY THE ABOVE NAMED MANUFACTURER AND ARE BEING RESOLD BY THERMACUT. THERMACUT RESERVES THE RIGHT TO SUBSTITUTE OEM PARTS IN PLACE OF THERMACUT PARTS. VALID FROM SEPTEMBER 2024 • PREVIOUS VERSION IS NO LONGER VALID. • © COPYRIGHT 2024 BY THERMACUT® CZECH REPUBLIC. ALL RIGHTS RESERVED.

THERMACUT® REPLACEMENT PARTS SUITABLE FOR
Thermal Dynamics®
MERLIN™ 6000 & 6000GST | MAXIMIZER™ 300

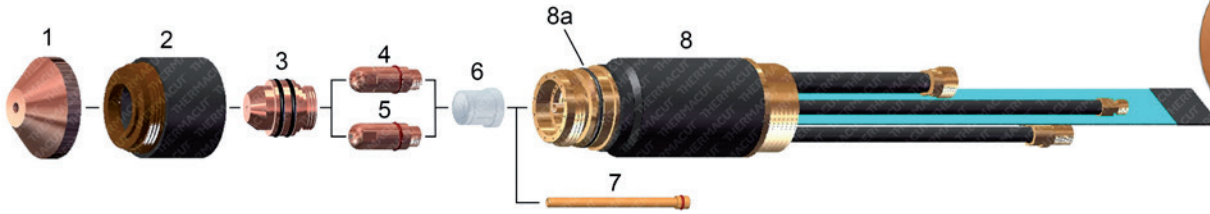

Item	Part No.	Ref. No.	Description	Std. Pkg.	Item	Part No.	Ref. No.	Description	Std. Pkg.
1.	T-2971	20-1003	Shield 50A	1		T-10265**	20-1010-UR	Electrode 100-225A, Air/O ₂	5
	T-2289	20-1004	Shield 100-225A	1	5.	T-2300	20-1023	Electrode 50-300A, N ₂	5
	T-2290	20-1005	Shield 300A	1	6.	T-2301	20-0008	Gas Distributor 50-225A	2
2.	T-2292	20-1002	Standard Shield Cup Body	1		T-2302	20-1009	Gas Distributor 300A	2
3.	T-8981	20-1030	Tip 0.043" 50A	5	7.	T-11846	T-11846	Cooling Tube	1
	T-2303	20-1031	Tip 0.055" 100A	5	8.	T-1693	9-6410	Torch Body	1
	T-2304	20-1032	Tip 0.073" 150A	5	8a.	N-10088	1-023B	O-Ring	1
	T-2305	20-1033	Tip 0.083" 225A	5	NS	T-1077	7-3207	Mounting Tube	1
	T-2306	20-1034	Tip 0.109" 300A	5	NS	T-0160	7-2827 OEM	Pinion Assembly	1
4.	T-10293**	20-1015-UR	Electrode 50-100A, O ₂	10					
	T-10440**	20-1016-UR	Electrode 150A, O ₂	5					
	T-10264**	20-1018-UR	Electrode 50-225A, Air (300A, O ₂)	5					

THERMACUT® REPLACEMENT PARTS SUITABLE FOR
PCH/M-120

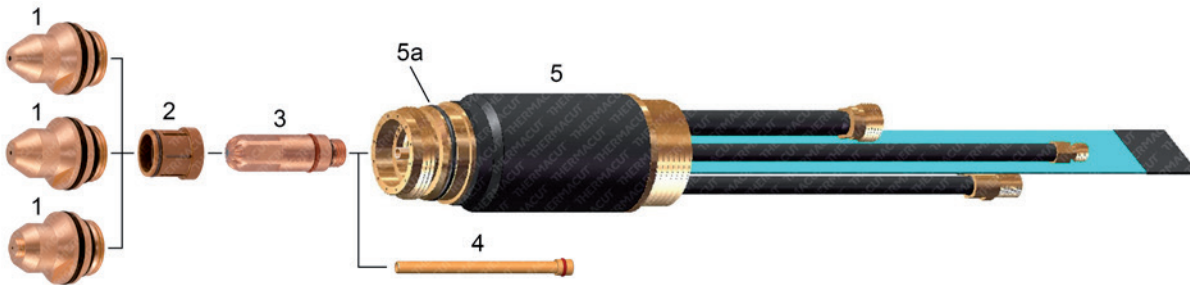

Item	Part No.	Ref. No.	Description	Std. Pkg.	Item	Part No.	Ref. No.	Description	Std. Pkg.
1.	T-0577	20-1222	Tip .063 120A	5	3.	T-10263	20-1210-UR	Electrode	5
	T-0570	20-1221	Tip .047 70A	5	4.	T-11846	T-11846	Cooling Tube	1
	T-0582	20-1220	Tip .031 35A	5	5.	T-1693	9-6410	Torch Body	1
2.	T-0569	20-1215	Gas Distributor	1	5a.	N-10088	1-023B	O-Ring	1

** A UNIQUE DESIGN WHICH ENHANCES PERFORMANCE AND DIFFERS FROM OEM DESIGNS

NS NOT SHOWN IN THE PICTURE

SMART SOLUTION - DESIGN IMPROVEMENTS THAT BRINGS ADDED VALUE SUCH AS IMPROVED LIFETIME OF CONSUMABLES, EXCELLENT CUT QUALITY, SPEED OR BETTER COST EFFECTIVENESS OF YOUR SYSTEM

THERMACUT®, FHT-EX® AND EX-TRAFIRE® ARE REGISTERED TRADEMARKS OF THERMACUT, K. S. AND MAY BE REGISTERED IN CZECH REPUBLIC AND/OR OTHER COUNTRIES. ALL OTHER TRADEMARKS ARE PROPERTIES OF THEIR RESPECTIVE OWNERS. THERMACUT IS NO WAY AFFILIATED WITH Thermal Dynamics®. MOST THERMACUT PARTS ARE MADE FOR OR BY AN IBG COMPANY. PARTS INDICATED WITH A OEM ARE ORIGINAL PARTS MANUFACTURED BY THE ABOVE NAMED MANUFACTURER AND ARE BEING RESOLD BY THERMACUT. THERMACUT RESERVES THE RIGHT TO SUBSTITUTE OEM PARTS IN PLACE OF THERMACUT PARTS. VALID FROM SEPTEMBER 2024 • PREVIOUS VERSION IS NO LONGER VALID. • © COPYRIGHT 2024 BY THERMACUT® CZECH REPUBLIC. ALL RIGHTS RESERVED.

THERMACUT® REPLACEMENT PARTS SUITABLE FOR Thermal Dynamics® PWH/M 2A WELDING TORCH

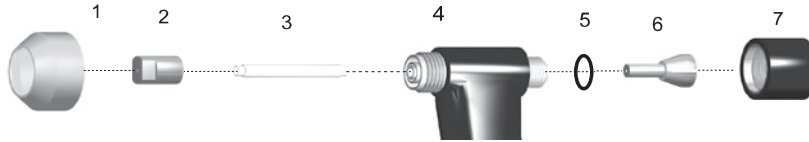

Item	Part No.	Ref. No.	Description	Std. Pkg.	Item	Part No.	Ref. No.	Description	Std. Pkg.
1.	T-1482	8-2071	Shield Cup	5	4.	T-1491	8-2036	Gasket	5
	T-0776	8-3236 OEM	Shield Cup, Ext.	10		T-1492	8-2027	Torch Head, 70°	1
2.	T-1483	8-2023	Tip, .046, 35A	10		T-1037	8-2028	Torch Head, 90°	1
	T-1484	8-2024	Tip, .062, 55A	10		T-1493	8-2097	Torch Head, Machine	1
	T-1485	8-2025	Tip, .081, 75A	10	5.	T-1494	8-2035	O-Ring	10
	T-1486	8-2079	Tip, Long, .031	10	6.	T-1495	8-2039-UR	Collet	1
	T-1487	8-2080	Tip, Long, .046	10		T-0766	8-2041	Collet (.040)	1
	T-1488	8-2082	Tip, Long, .062	10		T-0768	8-2044	Electrode (.040), Std.	10
	T-1489	8-2083	Tip, Long, .081	10		T-0769	8-2006 OEM	Electrode, Ext. (.093)	10
3.	T-1490	8-2040	Gas Distributor	1	7.	T-1497	8-2032	Back Cap	1
	T-0770	8-2042	Gas Distributor (.040)	1		T-0765	8-2030	Back Cap, Extended	1

Hand Torch



Machine Torch

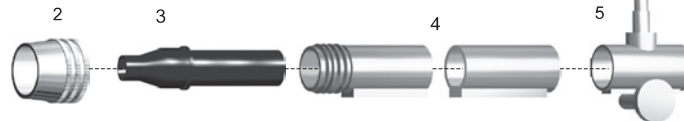

ACCESSORIES

Common Lead Set Components

Item	Part No.	Ref. No.	Description	Std. Pkg.	Item	Part No.	Ref. No.	Description	Std. Pkg.
1.	T-1524	8-2026 OEM	Handle	1	NS	T-8089	8-2021	Wrench/Gauge	1
2.	T-0157	8-4018	Nut	1	NS	T-1535	8-1495	Positive Lead, Red 25'	1
3.	T-1525	8-2063 OEM	Sleeve	1	NS	T-1536	8-1074	Plasma Hose 12 1/2'	1
4.	T-0159	8-5005	Mounting Tube	1	NS	T-1537	8-1496	Plasma Hose 25'	1
5.	T-0160	7-2827 OEM	Pinion Assembly	1	NS	T-1520	8-1075	Shield Hose 12 1/2'	1
NS	T-1532	9-2105	Negative Lead, Green, 12-1/2'	1	NS	T-1521	8-1497	Shield Hose 25'	1
NS	T-1533	8-1494	Negative Lead, Green, 25'	1	NS	T-1446	8-3138	Sleeving 12 1/2'	1
NS	T-1534	9-2107	Positive Lead, Red 12-1/2'	1	NS	T-1447	8-3139	Sleeving 25'	1

Torch / Lead Sets with Quick Disconnect (QD)

Item	Part No.	Ref. No.	Description	Std. Pkg.	Item	Part No.	Ref. No.	Description	Std. Pkg.
NS	T-4106	2-2100	Hand Torch 70° with 12.5' Leads & QD	1	NS	T-4887	2-2102	Hand Torch 180° with 12.5' Leads & QD	1
NS	T-4888	2-2104	Hand Torch 70° with 25' Leads & QD	1	NS	T-4891	2-2106	Hand Torch 180° with 25' Leads & QD	1
NS	T-4899	2-2101	Hand Torch 90° with 12.5' Leads & QD	1	NS	T-4884	2-2103	Machine Torch 180° with 12.5' Leads & QD	1
NS	T-4890	2-2105	Hand Torch 90° with 25' Leads & QD	1	NS	T-4892	2-2107	Machine Torch 180° with 25' Leads & QD	1

Torch / Lead Sets without Quick Disconnect (QD)

Item	Part No.	Ref. No.	Description	Std. Pkg.	Item	Part No.	Ref. No.	Description	Std. Pkg.
NS	T-1528	2-2443	Hand Torch 70° with 12.5' Leads	1	NS	T-4872	2-2108	Hand Torch 180° with 25' Leads	1
NS	T-1529	2-2505	Hand Torch 70° with 25' Leads	1	NS	T-1530	2-2480	Machine Torch with 12.5' Leads	1
NS	T-4870	2-2504	Hand Torch, 70° with 25' Leads	1	NS	T-0774	2-2840	Machine Torch with 12.5' Leads	1
NS	T-0772	2-2444	Hand Torch 90° with Leads 12.5'	1	NS	T-1531	2-2594	Machine Torch with Leads 25'	1
NS	T-0775	2-2506	Hand Torch 90° with 25' Leads	1	NS	T-1526	4-2539	Leads 12.5'	1
NS	T-4871	2-3002	Hand Torch 180° with 12.5' Leads	1	NS	T-1527	4-2585	Leads 25'	1

THERMACUT®, FHT-EX® AND EX-TRAFIRE® ARE REGISTERED TRADEMARKS OF THERMACUT, K. S. AND MAY BE REGISTERED IN CZECH REPUBLIC AND/OR OTHER COUNTRIES. ALL OTHER TRADEMARKS ARE PROPERTIES OF THEIR RESPECTIVE OWNERS. THERMACUT IS NO WAY AFFILIATED WITH Thermal Dynamics®. MOST THERMACUT PARTS ARE MADE FOR OR BY AN IBG COMPANY. PARTS INDICATED WITH A OEM ARE ORIGINAL PARTS MANUFACTURED BY THE ABOVE NAMED MANUFACTURER AND ARE BEING RESOLD BY THERMACUT. THERMACUT RESERVES THE RIGHT TO SUBSTITUTE OEM PARTS IN PLACE OF THERMACUT PARTS. VALID FROM SEPTEMBER 2024 • PREVIOUS VERSION IS NO LONGER VALID. • © COPYRIGHT 2024 BY THERMACUT® CZECH REPUBLIC. ALL RIGHTS RESERVED.

THERMACUT® REPLACEMENT PARTS SUITABLE FOR Thermal Dynamics® PWH/M 3A WELDING TORCH



Item	Part No.	Ref. No.	Description	Std. Pkg.	Item	Part No.	Ref. No.	Description	Std. Pkg.
1.	T-1505	8-3040	Shield Cup	1		T-1499	8-3030	Torch Head 70°	1
	T-1911	8-3038	Shield Cup Standard Weight	1		T-1036	8-3031	Torch Head 90°	1
2.	T-1509	9-1783	Tip .046 50A, Standard	10	9.	T-1027	8-0527	O-Ring Electrode Cap	10
	T-1510	9-1784	Tip .062 75A, Standard	10	OD 10.	T-1502	9-1780	Collet	1
	T-1511	9-1785	Tip .081 100A, Standard	10	11.	T-1504	9-1779	Electrode Cap, Standard	1
	T-1512	9-1795	Tip .093 150A, Standard	10	12.	T-0777	9-1803	Electrode Cap, Extended	1
OD 3.	T-1513	9-1788	Tip, Long .031 10A, Extended	10	NS		9-1757	PWH Handle	1
	T-1514	9-1789	Tip, Long .046 20A, Extended	10	NS	T-10766	9-1778 OEM	Sleeve	1
	T-1515	9-1790	Tip, Long .062 55A, Extended	10	NS	T-0157	8-4018	Nut	1
	T-1516	9-1791	Tip, Long .081 75A, Extended	10	NS	T-0183	9-1901	Adaptor	1
	T-1517	9-1811	Tip, Long .093 85A, Extended	10	OD NS	T-0159	8-5005	Positioning Tube	1
4.	T-1518	9-2240	Gas Distributor Insulating Sleeve	5	NS	T-0161	8-4204	End Cap	1
OD 5.	T-1503	9-1747	Electrode	1	NS	T-0810	9-1810	Gage/Wrench	1
	NS	T-0078	Electrode Extended	5	NS	KT-1069	4-2615	PWH/M 3A Cable Leads 12.5' (3.8m) Hand/Mach.	1
6.	T-1498	8-3059	Gas Diffuser	1	NS	KT-1474	4-2624	PWH/M 3A Cable Leads 25' (7.6m) Hand/Mach.	1
7.	T-1519	8-3057	Gasket - Shield Cup	5	NS	KT-1067	2-2616	PWH 3A Hand Torch 180° 3.8m	1
8.	T-1500	8-3032	Torch Head Assembly (180° offset)	1					

Torch / Lead Sets with Quick Disconnect (QD)

ACCESSORIES

Item	Part No.	Ref. No.	Description	Std. Pkg.	Item	Part No.	Ref. No.	Description	Std. Pkg.
NS	T-4885	2-2110	Torch 70° W/12 1/2' Leads & QD	1	NS	T-4031	2-2112	Hand Torch 180° w/ 12.5' Leads & QD	1
NS	T-4886	2-2114	Hand Torch 70° w/25' Leads & QD	1	NS	T-4170	2-2116	Hand Torch 180° w/ 25' Leads & QD	1
NS	T-4181	2-2111	Hand Torch 90° w/ 12.5' Leads & QD	1	NS	T-4893	2-2113	Machine Torch 180° w/ 12.5' Leads & QD	1
NS	T-4013	2-2115	Hand Torch 90° w/ 25' Leads & QD	1	NS	T-3925	2-2117	Machine Torch w/ 25' Leads & QD	1

Torch / Lead Sets without Quick Disconnect (QD)

Item	Part No.	Ref. No.	Description	Std. Pkg.	Item	Part No.	Ref. No.	Description	Std. Pkg.
NS	T-1466	4-2615	Leads 12 1/2'	1	NS	T-2953	2-2623	Hand Torch 90° w/ 25' Leads	1
NS	T-1467	4-2624	Leads 25'	1	NS	T-2868	2-2616	Hand Torch 180° w/ 12.5' Leads	1
NS	T-1468	2-2527	Torch 70° W/12 1/2' Leads	1	NS	T-4874	2-2621	Hand Torch 180° w/ 25' Leads	1
NS	T-1469	2-2599	Torch 70° W/25' Leads	1	NS	T-1470	2-2531	Machine Torch W/12 1/2' Leads	1
NS	T-4873	2-2529	Hand Torch 90° w/ 12.5' Leads	1	NS	T-1471	2-2624	Machine Torch W/25' Leads	1

OD ON DEMAND – WE DO NOT KEEP THESE PARTS IN STOCK, COST IS SET ACCORDING TO THE ORDERED QUANTITY, DELIVERY TIME MAY DIFFER FROM STANDARD PRODUCTS.
NS NOT SHOWN IN THE PICTURE

THERMACUT®, FHT-EX® AND EX-TRAFIRE® ARE REGISTERED TRADEMARKS OF THERMACUT, K. S. AND MAY BE REGISTERED IN CZECH REPUBLIC AND/OR OTHER COUNTRIES. ALL OTHER TRADEMARKS ARE PROPERTIES OF THEIR RESPECTIVE OWNERS. THERMACUT IS NO WAY AFFILIATED WITH Thermal Dynamics®. MOST THERMACUT PARTS ARE MADE FOR OR BY AN IBG COMPANY. PARTS INDICATED WITH A OEM ARE ORIGINAL PARTS MANUFACTURED BY THE ABOVE NAMED MANUFACTURER AND ARE BEING RESOLD BY THERMACUT. THERMACUT RESERVES THE RIGHT TO SUBSTITUTE OEM PARTS IN PLACE OF THERMACUT PARTS.
VALID FROM SEPTEMBER 2024 • PREVIOUS VERSION IS NO LONGER VALID. • © COPYRIGHT 2024 BY THERMACUT® CZECH REPUBLIC. ALL RIGHTS RESERVED.

THERMACUT® REPLACEMENT PARTS SUITABLE FOR
Thermal Dynamics®
PWH/M 4A WELDING TORCH



Item	Part No.	Ref. No.	Description	Std. Pkg.	Item	Part No.	Ref. No.	Description	Std. Pkg.
1.	T-12352	8-4064 OEM	Shield Cup with Lens	5	12.	T-2144	9-1877	Electrode Cap, Extended	1
2.	T-1451	9-1847	Tip .062 100A, Standard	10	NS	T-2146	9-2204	Gas Distributor	1
	T-1453	9-1849	Tip .125 250A, Standard	10	OD NS	T-1457	8-0528	O-Ring	10
3.	T-1020	9-1890	Tip .062 100A, Extended	10	NS	T-0157	8-4018	Nut	1
	T-2145	9-1891	Tip .093 125A, Extended	10	OD NS	T-0183	9-1901	Adaptor	1
	T-2355	9-1892	Tip .125 250A, Extended	5	NS	T-0159	8-5005	Positioning Tube	1
4.	T-1454	9-1827	Electrode .187, Standard	5	NS	KT-1484	2-2120	PWH 4A 70° Torch with Leads 12.5' (3.8m), centr. conn.	1
	T-2134	9-1834	Electrode .187, Extended	5	NS	KT-1357	2-2125	PWH 4A 70° Torch with Leads 25' (7.6m), centr. conn.	1
5.	T-2105	8-4011	Liner (without Gas Distributor)	1	NS	KT-1377	2-2829	PWH 4A 180° Torch with Leads 25' (7.6m), centr. conn.	1
6.	T-1455**	8-4012-UR	Liner (Gas Distributor included)	1	NS	KT-1207	9-3088	PWH, M4A Hose, Shield, 4A/6A, 25'	1
7.	T-1458	8-4024	Collar	1	NS	KT-1206	8-1505	PWH, M4A Hose, Plas., 25'	1
8.	T-11543	8-4040 OEM	Shield Gas Diffuser, Threaded	1	NS	KT-1186	9-2079	PWH, M4A Lead, neg. W.C., 12.5' (3.8m)	1
9.	T-0197	8-4069	Gasket - Shield Cup	5	NS	KT-1200	9-2081	PWH, M4A Lead, pos. W.C., 12.5' (3.8m)	1
10.	T-1460	8-4014	Torch Head Assembly 70°	1	NS	KT-1201	8-1398	PWH, M4A Lead, neg. W.C., 25' (7.6m)	1
	T-1303	8-4016	Torch Head Assembly 180° offset	1	NS	KT-1202	8-1399	PWH, M4A Lead, pos. W.C., 25' (7.6m)	1
	T-0075	8-4015	Torch Head Assembly 90°	1					
	T-1461	8-4054	Torch Head Assembly 180° inline	1					
11.	T-1463	9-1876	Collet	1					

OD ON DEMAND – WE DO NOT KEEP THESE PARTS IN STOCK, COST IS SET ACCORDING TO THE ORDERED QUANTITY, DELIVERY TIME MAY DIFFER FROM STANDARD PRODUCTS.

****** A UNIQUE DESIGN WHICH ENHANCES PERFORMANCE AND DIFFERS FROM OEM DESIGNS

NS NOT SHOWN IN THE PICTURE

THERMACUT®, FHT-EX® AND EX-TRAFIRE® ARE REGISTERED TRADEMARKS OF THERMACUT, K. S. AND MAY BE REGISTERED IN CZECH REPUBLIC AND/OR OTHER COUNTRIES. ALL OTHER TRADEMARKS ARE PROPERTIES OF THEIR RESPECTIVE OWNERS. THERMACUT IS NO WAY AFFILIATED WITH Thermal Dynamics®. MOST THERMACUT PARTS ARE MADE FOR OR BY AN IBG COMPANY. PARTS INDICATED WITH A OEM ARE ORIGINAL PARTS MANUFACTURED BY THE ABOVE NAMED MANUFACTURER AND ARE BEING RESOLD BY THERMACUT. THERMACUT RESERVES THE RIGHT TO SUBSTITUTE OEM PARTS IN PLACE OF THERMACUT PARTS. VALID FROM SEPTEMBER 2024 • PREVIOUS VERSION IS NO LONGER VALID. • © COPYRIGHT 2024 BY THERMACUT® CZECH REPUBLIC. ALL RIGHTS RESERVED.

THERMACUT® REPLACEMENT PARTS SUITABLE FOR
Thermal Dynamics®
PWH/M 4A WELDING TORCH

ACCESSORIES

Torch / Lead Sets with Quick Disconnect (QD)

Item	Part No.	Ref. No.	Description	Std. Pkg	Item	Part No.	Ref. No.	Description	Std. Pkg
NS	T-4092	2-2120	Hand Torch 70° w/ 12.5' Leads & QD	1	NS	T-4897	2-2122	Machine Torch 180° w/ 12.5' Leads & QD	1
NS	T-4562	2-2125	Hand Torch 70° w/ 25' Leads & QD	1	NS	T-4896	2-2128	Machine Torch 180° w/ 25' Leads & QD	1
NS	T-4880	2-2119	Hand Torch 90° w/ 12.5' Leads & QD	1	NS	T-4894	2-2123	Hand Torch 180° w/ 12.5' Leads & QD	1
NS	T-4887	2-2126	Hand Torch 90° w/ 25' Leads & QD	1	NS	T-4899	2-2129	Hand Torch 180° w/ 25' Leads & QD	1
NS	T-4898	2-2121	Hand Torch 180° w/ 12.5' Leads & QD	1	NS	T-4882	2-2124	Machine Torch 180° w/ 12.5' Leads & QD	1
NS	T-4895	2-2127	Hand Torch 180° w/ 25' Leads & QD	1	NS	T-4883	2-2130	Machine Torch 180° w/ 25' Leads & QD	1
NS	KT-1377	2-2829	Hand Torch 180° w/ 25' Leads & QD	1					

Torch / Lead Sets without Quick Disconnect (QD)

Item	Part No.	Ref. No.	Description	Std. Pkg	Item	Part No.	Ref. No.	Description	Std. Pkg
NS	T-1434	2-2821	Hand Torch 70° w/ 12.5' Leads	1	NS	T-4878	2-2850	Hand Torch 180° w/ 12.5' Leads	1
NS	T-1435	2-2820	Hand Torch 70° w/ 25' Leads	1	NS	T-4531	2-2851	Hand Torch 180° w/ 25' Leads	1
NS	T-4875	2-2819	Hand Torch 90° w/ 12.5' Leads	1	NS	T-2869	2-2803	Machine Torch 180° Inline w/ 12.5' Leads	1
NS	T-2917	2-2818	Hand Torch 90° w/ 25' Leads	1	NS	T-3869	2-2804	Machine Torch 180° Inline w/ 25' Leads	1
NS	T-1436	2-2482	Machine Torch 180° Offset w/ 12.5' Leads	1					
NS	T-1437	2-2592	Machine Torch 180° Offset w/ 25' Leads	1					

THERMACUT®, FHT-EX® AND EX-TRAFIRE® ARE REGISTERED TRADEMARKS OF THERMACUT, K. S. AND MAY BE REGISTERED IN CZECH REPUBLIC AND/OR OTHER COUNTRIES. ALL OTHER TRADEMARKS ARE PROPERTIES OF THEIR RESPECTIVE OWNERS. THERMACUT IS NO WAY AFFILIATED WITH Thermal Dynamics®. MOST THERMACUT PARTS ARE MADE FOR OR BY AN IBG COMPANY. PARTS INDICATED WITH A OEM ARE ORIGINAL PARTS MANUFACTURED BY THE ABOVE NAMED MANUFACTURER AND ARE BEING RESOLD BY THERMACUT. THERMACUT RESERVES THE RIGHT TO SUBSTITUTE OEM PARTS IN PLACE OF THERMACUT PARTS. VALID FROM SEPTEMBER 2024 • PREVIOUS VERSION IS NO LONGER VALID. • © COPYRIGHT 2024 BY THERMACUT® CZECH REPUBLIC. ALL RIGHTS RESERVED.

THERMACUT® REPLACEMENT PARTS SUITABLE FOR
Thermal Dynamics®
PWM 300 WELDING TORCH

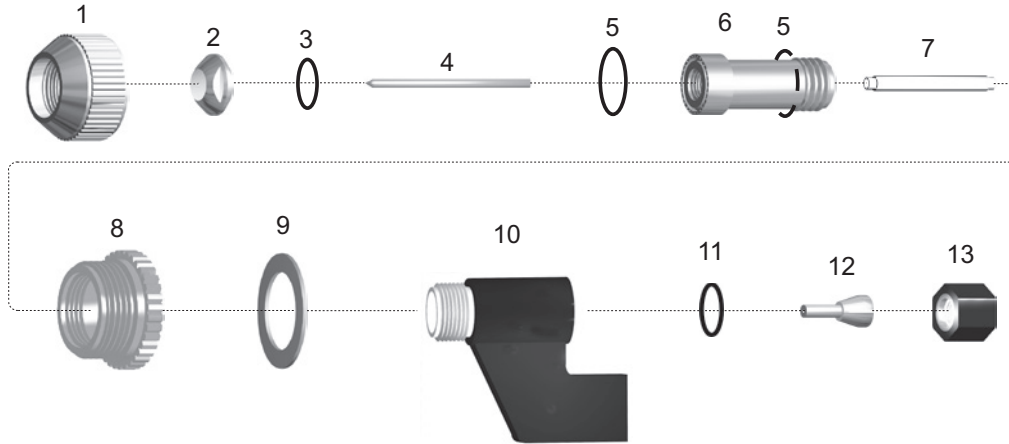

Item	Part No.	Ref. No.	Description	Std. Pkg.	Item	Part No.	Ref. No.	Description	Std. Pkg.
1.	T-2360	8-4373	End Cap	1	7.	T-2365	8-6651	Insulating Sleeve	10
2.	T-2361	8-4370	Tip .093 200A	5	8.	T-2366	8-6652 OEM	Shield Cup Diffuser	1
	T-2362	8-4371	Tip .113 250A	5	9.	T-0230	8-6512	Gasket	5
	T-2363	8-4372	Tip .125 300A	5	10.	T-2369	8-6649	Torch Body	1
OD 3.	T-2152	9-2863	O-Ring	10	OD 11.	T-2082	8-0534	O-Ring	10
4.	T-1454	9-1827	Electrode	5	12.	T-2367	8-6650	Collet	1
5.	T-1029	9-2956	O-Ring	10	13.	T-2368	8-6654	Electrode Cap	1
6.	T-2364	8-6509	Liner (includes 50-720S 2x)	1	NS		8-6542 OEM	Shield Cup	1

ACCESSORIES

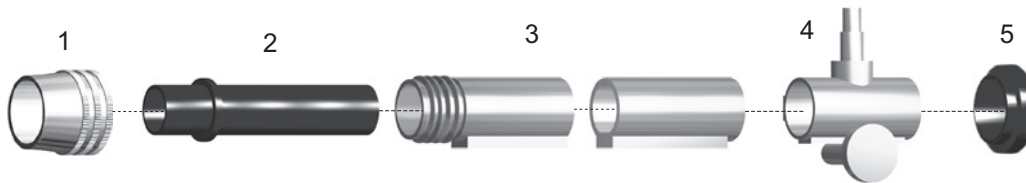

Item	Part No.	Ref. No.	Description	Std. Pkg.	Item	Part No.	Ref. No.	Description	Std. Pkg.
1.	T-0157	8-4018	Nut	1	NS	KT-1251	2-2846	PMW300 with 25' Leads	1
OD 2.	T-0183	9-1901	Adapter	1	NS	KT-1207(T-1445)	9-3088	PWH, M4A® Hose, Shield, 4A/6A, 25'	1
3.	T-0159	8-5005	Mounting Tube	1	NS	KT-1206(T-1443)	8-1505	PWH, M4A® Hose, Plas., 25'	1
OD 4.	T-0160	7-2827 OEM	Pinion Assembly	1	NS	KT-1186(T-1438)	9-2079	PWH, M4A® Lead, neg. W.C. 12.5' (3.8m)	1
5.	T-0161	8-4204	Bushing	1	NS	KT-1200(T-1440)	9-2081	PWH, M4A® Lead, pos. W.C. 12.5' (3.8m)	1
	NS	KT-1199	Torch Leads 12.5ft	1	NS	KT-1201(T-1439)	8-1398	PWH, M4A® Lead, neg. W.C. 25' (7.6m)	1
OD NS	KT-1204	4-2544	Torch Leads 25ft	1	NS	KT-1202(T-1441)	8-1399	PWH, M4A® Lead, pos. W.C. 25' (7.6m)	1
	NS	KT-1055	PMW300 with 12.5' Leads	1					

OD ON DEMAND – WE DO NOT KEEP THESE PARTS IN STOCK, COST IS SET ACCORDING TO THE ORDERED QUANTITY, DELIVERY TIME MAY DIFFER FROM STANDARD PRODUCTS.

NS NOT SHOWN IN THE PICTURE

THERMACUT®, FHT-EX® AND EX-TRAFIRE® ARE REGISTERED TRADEMARKS OF THERMACUT, K. S. AND MAY BE REGISTERED IN CZECH REPUBLIC AND/OR OTHER COUNTRIES. ALL OTHER TRADEMARKS ARE PROPERTIES OF THEIR RESPECTIVE OWNERS. THERMACUT IS NO WAY AFFILIATED WITH Thermal Dynamics®. MOST THERMACUT PARTS ARE MADE FOR OR BY AN IBG COMPANY. PARTS INDICATED WITH A OEM ARE ORIGINAL PARTS MANUFACTURED BY THE ABOVE NAMED MANUFACTURER AND ARE BEING RESOLD BY THERMACUT. THERMACUT RESERVES THE RIGHT TO SUBSTITUTE OEM PARTS IN PLACE OF THERMACUT PARTS. VALID FROM SEPTEMBER 2024 • PREVIOUS VERSION IS NO LONGER VALID. • © COPYRIGHT 2024 BY THERMACUT® CZECH REPUBLIC. ALL RIGHTS RESERVED.

ACCESSORIES





Thermacut coolants are suitable for plasma cutting and welding, as well as for welding processes mig, mag, tig (wig) and other industrial applications.

- Specification: max. conductivity 10 s/cm, ph 6-8, resists freezing to -12 °C (+10 °F).
- CFPG composition: de-ionized water and propylene glycol.
- CF2 composition: de-ionized water and ethylene glycol.
- Coolant is fully compatible and mixable with original coolants.
- Ecological, fully degradable in the environment.

Item	Part No.	Ref. No.	Description	Std. Pkg
1.		CFPG-1G	Inhibited Propylene Glycol based coolant	4
		CF2-1G	Ethylene Glycol based coolant	4

ANTI-SPATTER SPRAY



- Provides instant shielding action against spatter.
- Highly heat resistant.
- Reduces downtime due to spatter build-up.
- No shaking or mixing necessary.
- Will not spread beyond point of impact.
- Paint compatible and residual spatter may be brushed or wiped away before painting.

Item	Part No.	Ref. No.	Description	Std. Pkg
2.		ES-16-A	Anti-spatter spray - water based	1
		AS-16-A	Anti-spatter spray - 16 OZ	1
		T-12762	Anti-spatter - Ceramic	1

PLASMA TABLE FLUID

Item	Part No.	Ref. No.	Description	Std. Pkg
NS		PATF-5G	Plasma Table Fluid	1

THERMACUT® ELECTRICAL CONDUCTIVITY METER

▶ VIDEO AVAILABLE AT YOUTUBE CHANNEL ▶



Professional tool for checking coolant condition, includes a sturdy plastic case. For use in Plasma, MIG, TIG (WIG). Coolant conductivity above a specific limit dramatically decreases consumable lifetime and increases costs of cutting (welding).

Item	Part No.	Ref. No.	Description	Std. Pkg.
1.	T-12800	T-12800	Electrical Conductivity Meter	1

ELECTRODE PIT-DEPTH GAUGE

▶ VIDEO AVAILABLE AT YOUTUBE CHANNEL ▶



- Electrode Pit-Depth Gauge allows the operator to determine how much electrode life remains.
- Replacing the electrode at the same time as the nozzle could mean replacing electrodes which still are working properly.
- Cost-saving investment.
- Sturdy carrying case included.
- See product brochere for electrode burn limits and product details.

Item	Part No.	Ref. No.	Description	Std. Pkg
1.	T-11600	T-11600	Electrode Pit-Depth Gauge	1



Filter for compressed air has been designed to remove moisture, oil aerosols and particulates coming from air compressor. It provides clean, dry and oil-free air, essential for any industrial application.

The filter must be installed as close as possible downstream of the air pressure regulator, in addition to dryers and other filters rather than replacement of the same. The Filter-EX will remove oil aerosols, smokes, moistures and particulates passing through the conventional equipments.

Data Sheet

Filtering Degree: 0.01 µinch - 0.25 µm
 Maximum Pressure: 125 PSI - 8.5 bar
 Maximum Flow @ 80%: 2700 SCFH - 1250 l/min.
 Temperature Range: 15-140 °F / -10 +60 °C
 Size Pipe: 1/4"
 Dimension: Ø 5.2" × 7.9" - Ø 132 × 200 mm

Item	Part No.	Ref. No.	Description	Std. Pkg
1.	T-12452	EX-0-804-001	Air Filter (without connection couplings), includes O-Ring (item 3) and 1 pc Filter Cartridge (item 2)	1
2.	T-12453	EX-0-804-002	Cartridge for Air Filter	8
3.	N-23219	O-KR-117x3,5G	Spare part, O-Ring D117×3.5 Nitrile	1
4.	EX-0-802-001	EX-0-802-001	DN 7.2 ES Quick Connect Plug with male thread G 1/4"	1
5.	EX-0-802-002	EX-0-802-002	DN 7.2 ES Quick Connect Coupling with male thread G 1/4"	1

HEAT SHIELD GREASE



Grease will make strong heat shield barrier on the front shield of the torch and cover the parts effectively against melted spatter, which are destroying the parts.
 - Highly appreciated for high amperage cutting or aluminum cutting applications.
 - Please see product brochure for details.

Item	Part No.	Ref. No.	Description	Std. Pkg	Weight	Dimensions (cm) L×W×H
1.	T-12777	T-12777	Heat Shield Grease, 400g	1	400g	
	T-11701	T-11701	Heat Shield Grease, 50ml	1		

THERMACUT® SILICONE LUBRICANT

1



Silicone lubricant makes consumables change easy and helps avoid gas/coolant leaking. Stable in high temperature and O₂.

Item	Part No.	Ref. No.	Description	Std. Pkg
1.	T-0994	027055	Silicone Lubricant 25ml	1

SAFETY GLASS SHIELD

1



Heavy Duty genuine leather casing with standard welding glass 90 × 110 mm DIN12, which can be easily replaced in case of breaking. Make plasma arc visible to reach best cut quality and effectivity.

Item	Part No.	Ref. No.	Description	Std. Pkg
1.	T-11768	T-11768	Safety Glass Shield	1

THERMACUT® CONSUMABLE CASE SUITABLE FOR Hypertherm® HPR®130/HPR®260

PRODUCT BROCHURE WITH DETAILS AT
WWW.THERMACUT.COM

PORTABLE AND PRACTICAL CONSUMABLE CASE CONTAINS THE MILD STEEL CUTTING LINE OF 130A AND 260A CONSUMABLES SUITABLE FOR THE HYPERTHERM® HPR®130/HPR®260 PLASMA CUTTING SYSTEM. THE KIT ALSO CONTAINS THE THERMACUT® REPLACEMENT TORCH, ADAPTOR AND THE TOOL NECESSARY FOR CONSUMABLE REPLACEMENT.



Item	Part No.	Ref. No.	Description	Std. Pkg.	Item	Part No.	Ref. No.	Description	Std. Pkg.
1.	T-11144	220176	Inner Retaining Cap 80/130A	1	13.	T-10938	220439	Nozzle 260A	5
2.	T-11150	220433	Inner Retaining Cap 260A	1	a 14.	T-9920	220181-UR	Electrode 130A	3
3.	T-9961	220173-UR	Shield Cap 30-130A	1	a 15.	T-9974	220435-UR	Electrode 260A	3
4.	T-9964	220398-UR	Shield Cap 200/260A (130/260A, Bevel)	1	a 16.	T-11203	220181-PRO	Electrode 130A (=220665-PRO), Silver PRO	1
5.	T-11138	220163	Receptacle Q. D. Original design	1	a 17.	T-11197	220435-PRO	Electrode 260A (=220668-PRO), Silver PRO	1
6.	T-11137	220162	Torch Q. D. Orig. design (included 2pcs. Cooling Tube 220340-UR)	1	a 18.	T-4917	220181-AG	Electrode 130A, SilverEX-®	1
a 7.	T-9882	220340-UR	Cooling Tube 30-260A	1	a 19.	T-4926	220435-AG	Electrode 260A, SilverEX-®	1
8.	T-9970	220440-UR	Shield 260A	4	20.	T-0994	027055	Silicone Lubricant 25ml	1
9.	T-9839	220183	Shield 130A	2	*21.	TN-0069*	104119-UR	Consumables Removal Tool	1
10.	T-10295	220179	Swirl Ring 80/130 (130A Bevel)	1	22.	T-12444		Box with Parts	1
11.	T-10271	220436	Swirl Ring 260A (260A Bevel)	1	OD 23.	T-12445		Empty Box	1
12.	T-10934	220182	Nozzle 130A	5					

* FULLY INTERCHANGEABLE WITH ORIGINAL PARTS, BUT DIFFERS FROM ORIGINAL DESIGN

a THERMACUT® ELECTRODES HAS TO BE USED WITH THERMACUT® DESIGN COOLING TUBE, OTHERWISE IT DOESN'T FIT TO THE TORCH, THERMACUT® COOLING TUBE CAN BE USED FOR THERMACUT® DESIGN ELECTRODES AND FOR ORIGINAL DESIGN TOO

OD ON DEMAND – WE DO NOT KEEP THESE PARTS IN STOCK, COST IS SET ACCORDING TO THE ORDERED QUANTITY, DELIVERY TIME MAY DIFFER FROM STANDARD PRODUCTS.

** SHIELD OFFERS BETTER LIFETIME BECAUSE OF IMPROVED DESIGN AND IS FULLY INTERCHANGEABLE AND COMPATIBLE WITH ORIGINAL PARTS

-PRO SILVER PRO TECHNOLOGY INCREASES ELECTRODE LIFETIME SIGNIFICANTLY COMPARED TO STANDARD COPPER ELECTRODES

THERMACUT®, FHT-EX® AND EX-TRAFIRE® ARE REGISTERED TRADEMARKS OF THERMACUT, K. S. AND MAY BE REGISTERED IN CZECH REPUBLIC AND/OR OTHER COUNTRIES. ALL OTHER TRADEMARKS ARE PROPERTIES OF THEIR RESPECTIVE OWNERS. THERMACUT IS NO WAY AFFILIATED WITH HYPERTHERM®. MOST THERMACUT PARTS ARE MADE FOR OR BY AN IBG COMPANY. PARTS INDICATED WITH A OEM ARE ORIGINAL PARTS MANUFACTURED BY THE ABOVE NAMED MANUFACTURER AND ARE BEING RESOLD BY THERMACUT. THERMACUT RESERVES THE RIGHT TO SUBSTITUTE OEM PARTS IN PLACE OF THERMACUT PARTS.

VALID FROM SEPTEMBER 2024 • PREVIOUS VERSION IS NO LONGER VALID. • © COPYRIGHT 2024 BY THERMACUT® CZECH REPUBLIC. ALL RIGHTS RESERVED.

THERMACUT® CONSUMABLE CASE SUITABLE FOR Hypertherm® HPR®130XD/HPR®260XD

PORTABLE AND PRACTICAL CONSUMABLE CASE CONTAINS THE MILD STEEL CUTTING LINE OF 130A AND 260A CONSUMABLES SUITABLE FOR THE HYPERTHERM® HPR®130XD/HPR®260XD PLASMA CUTTING SYSTEM. THE KIT ALSO CONTAINS THE THERMACUT® REPLACEMENT TORCH, ADAPTOR AND THE TOOL NECESSARY FOR CONSUMABLE REPLACEMENT.



Item	Part No.	Ref. No.	Description	Std. Pkg.	Item	Part No.	Ref. No.	Description	Std. Pkg.
1.	T-11273	220756	Inner Retaining Cap 80/130A	1	13.	T-10938	220439	Nozzle 260A	5
a 2.	T-11275	220760-UR	Inner Retaining Cap 260A	1	b 14.	T-9920	220181-UR	Electrode 130A	3
3.	T-11271	220747	Shield Cap 30-130A	1	b 15.	T-9974	220435-UR	Electrode 260A	3
a 4.	T-11270	220637-UR	Shield Cap 200-400A	1	b 16.	T-11203	220181-PRO	Electrode 130A (=220665-PRO), Silver PRO	1
5.	T-11844	220705	Quick-Disconnect Receptacle	1	b 17.	T-11197	220435-PRO	Electrode 260A (=220668-PRO), Silver PRO	1
6.	T-11834	220706	Quick-Disconnect Torch	1	b 18.	T-4917	220181-AG	Electrode 130A, SilverEX-®	1
b 7.	T-9882	220340-UR	Cooling Tube 30-260A	1	b 19.	T-4926	220435-AG	Electrode 260A, SilverEX-®	1
a 8.	T-11277	220764-UR	Shield 260A	4	20.	T-0994	027055	Silicone Lubricant 25ml	1
9.	T-9839	220183	Shield 130A	2	*21.	TN-0069*	104119-UR	Consumables Removal Tool	1
10.	T-10295	220179	Swirl Ring 80/130A (80/130A Bevel)	1	22.	T-12446		Box with Parts	1
11.	T-10271	220436	Swirl Ring 260A (260A Bevel)	1	23.	T-12447		Empty Box	1
12.	T-10934	220182	Nozzle 130A	5					

* FULLY INTERCHANGEABLE WITH ORIGINAL PARTS, BUT DIFFERS FROM ORIGINAL DESIGN

a MUST BE USED ONLY AS A SET OF SHIELD, SHIELD CAP AND INNER RETAINING CAP, THIS COMPLETE SET IS INTERCHANGEABLE AND COMPATIBLE WITH ORIGINAL PARTS.

b THERMACUT® ELECTRODES HAS TO BE USED WITH THERMACUT® DESIGN COOLING TUBE, OTHERWISE IT DOESN'T FIT TO THE TORCH, THERMACUT® COOLING TUBE CAN BE USED FOR THERMACUT® DESIGN ELECTRODES AND FOR ORIGINAL DESIGN TOO.

-**PRO** SILVER PRO TECHNOLOGY INCREASES ELECTRODE LIFETIME SIGNIFICANTLY COMPARED TO STANDARD COPPER ELECTRODES

THERMACUT®, FHT-EX® AND EX-TRAFIRE® ARE REGISTERED TRADEMARKS OF THERMACUT, K. S. AND MAY BE REGISTERED IN CZECH REPUBLIC AND/OR OTHER COUNTRIES. ALL OTHER TRADEMARKS ARE PROPERTIES OF THEIR RESPECTIVE OWNERS. THERMACUT IS NO WAY AFFILIATED WITH HYPERTHERM®. MOST THERMACUT PARTS ARE MADE FOR OR BY AN IBG COMPANY. PARTS INDICATED WITH A OEM ARE ORIGINAL PARTS MANUFACTURED BY THE ABOVE NAMED MANUFACTURER AND ARE BEING RESOLD BY THERMACUT. THERMACUT RESERVES THE RIGHT TO SUBSTITUTE OEM PARTS IN PLACE OF THERMACUT PARTS.

VALID FROM SEPTEMBER 2024 • PREVIOUS VERSION IS NO LONGER VALID. • © COPYRIGHT 2024 BY THERMACUT® CZECH REPUBLIC. ALL RIGHTS RESERVED.

THERMACUT® CONSUMABLE CASE SUITABLE FOR ESAB® PT-36™

PORTABLE AND PRACTICAL CONSUMABLE CASE CONTAINS THE MILD STEEL CUTTING LINE CONSUMABLES SUITABLE FOR THE ESAB® PT-36™ PLASMA CUTTING SYSTEM. THE KIT ALSO CONTAINS THE THERMACUT® REPLACEMENT TORCH AND THE TOOL NECESSARY FOR CONSUMABLE REPLACEMENT.



Item	Part No.	Ref. No.	Description	Std. Pkg.	Item	Part No.	Ref. No.	Description	Std. Pkg.
1.	T-10128	37081	Shield Retainer	1	13.	T-4636	0558001625	Gas Swirl Baffle, 8 × 0.047, 300-600A	1
2.	T-10334	0558006166	Shield Cup 6.6mm 290-450A	3	14.	T-11942	37073	Screw, Contact Ring	1
3.	T-2269	21944	Diffuser 100-600A	1	15.	T-11863	0558003858	Contact Ring with Screw 37073 (=37071)	1
4.	T-10129	37082	Nozzle Retaining Cap, Standard	1	16.	T-11208	0558003804	Torch Body PT-36™	1
5.	T-10970	0558006018	Nozzle 1.8mm 100/130A MS, 100A SS/AL	3	17.	N-20426	93750010	Hex Key Wrench	1
6.	T-10338	0558006020	Nozzle 2.0mm 150/200A MS/AL, 130/150A SS	3	OD 18.	T-11665	0558003918 OEM	Electrode Holder Wrench	1
7.	T-10443	0558006030	Nozzle 3.0mm 325/360A MS, 360A SS/AL	3	19.	T-0994	027055	Silicone Lubricant 25ml	1
OD 8.	T-10292	0558006041	Nozzle 4.1mm 600A SS/AL	2	20.	T-12020	T-12020	Box with Parts PT-36™	1
a 9.	T-11290	0558003914-PRO	Electrode 100-450A, O ₂ , Silver PRO	5	21.	T-12027	T-12027	Empty Box PT-36™	1
a 10.	T-11910	0558003928-UR	Electrode, N ₂ /H35	5					
a 11.	T-11319	0558003924-UR	Electrode Holder	1					
12.	T-4606	0558002533	Gas Swirl Baffle, 4 × 0.032, 100-280A	1					

- a** MUST BE USED AS A SET OF ELECTRODE HOLDER AND ELECTRODE, THIS COMPLETE SET IS INTERCHANGEABLE AND COMPATIBLE WITH ORIGINAL PARTS.
- OD** ON DEMAND – WE DO NOT KEEP THESE PARTS IN STOCK, COST IS SET ACCORDING TO THE ORDERED QUANTITY, DELIVERY TIME MAY DIFFER FROM STANDARD PRODUCTS.
- PRO** SILVER PRO TECHNOLOGY INCREASES ELECTRODE LIFETIME SIGNIFICANTLY COMPARED TO STANDARD COPPER ELECTRODES

THERMACUT®, FHT-EX® AND EX-TRAFIRE® ARE REGISTERED TRADEMARKS OF THERMACUT, K. S. AND MAY BE REGISTERED IN CZECH REPUBLIC AND/OR OTHER COUNTRIES. ALL OTHER TRADEMARKS ARE PROPERTIES OF THEIR RESPECTIVE OWNERS. THERMACUT IS NO WAY AFFILIATED WITH ESAB®. MOST THERMACUT PARTS ARE MADE FOR OR BY AN IBG COMPANY. PARTS INDICATED WITH A OEM ARE ORIGINAL PARTS MANUFACTURED BY THE ABOVE NAMED MANUFACTURER AND ARE BEING RESOLD BY THERMACUT. THERMACUT RESERVES THE RIGHT TO SUBSTITUTE OEM PARTS IN PLACE OF THERMACUT PARTS. VALID FROM SEPTEMBER 2024 • PREVIOUS VERSION IS NO LONGER VALID. • © COPYRIGHT 2024 BY THERMACUT® CZECH REPUBLIC. ALL RIGHTS RESERVED.

THERMACUT® CONSUMABLE CASE SUITABLE FOR Hypertherm® POWERMAX® 65 / POWERMAX® 85 / POWERMAX® 105

PORTABLE AND PRACTICAL CONSUMABLE CASE CONTAINS THE MILD STEEL CUTTING LINE CONSUMABLES SUITABLE FOR THE HYPERTHERM® POWERMAX® 65 / POWERMAX® 85 / POWERMAX® 105 PLASMA CUTTING SYSTEM. THE KIT ALSO CONTAINS THE THERMACUT® REPLACEMENT TORCH.

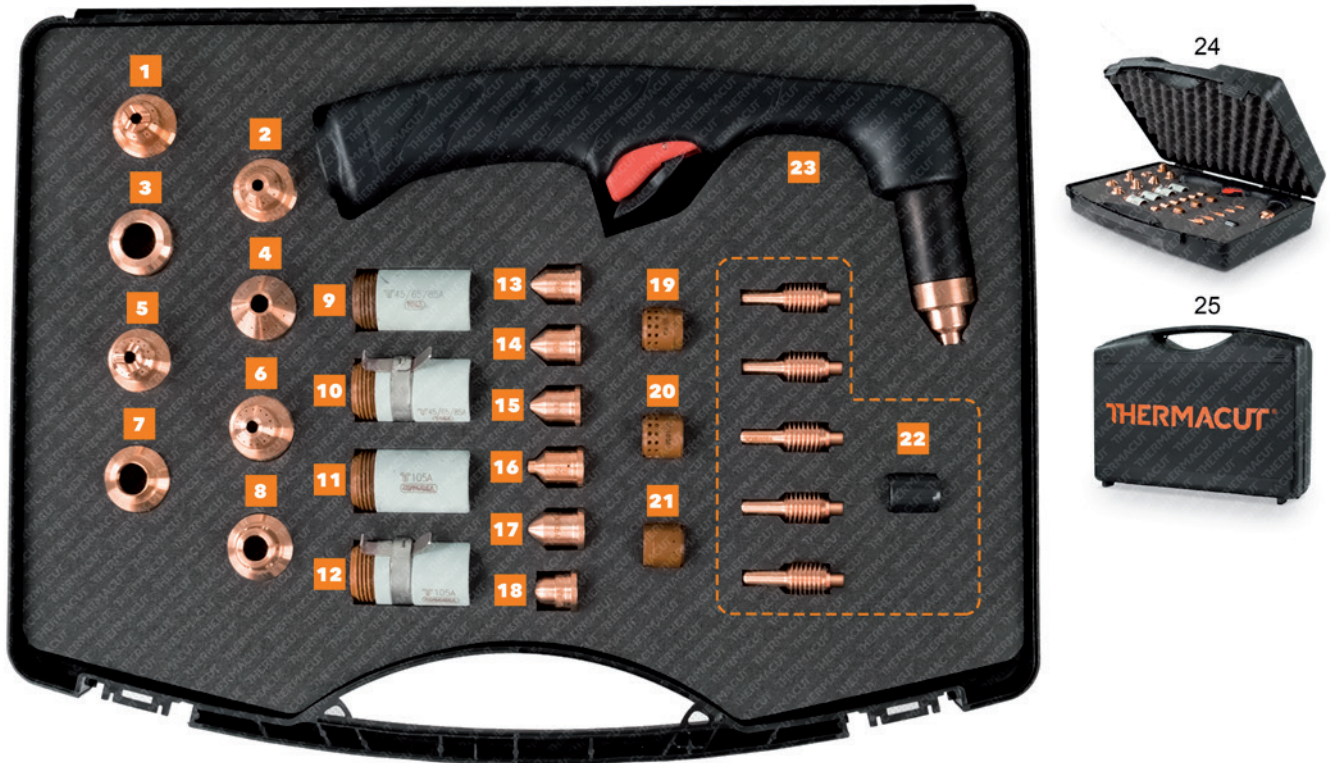

Item	Part No.	Ref. No.	Description	Std. Pkg.	Item	Part No.	Ref. No.	Description	Std. Pkg.
a 1.	T-11406	220818-UR	Shield 45/65/85A, Hand	1	a 14.	T-11377	220819-UR	Nozzle 65A	5
a 2.	T-11404	220817-UR	Shield 45/65/85A, Machine	1	a 15.	T-11405	220816-UR	Nozzle 85A	5
3.	T-11407	220955	Deflector 45/65/85/105A	1	b 16.	T-12023	220991-UR	Nozzle 105A, Gouging	5
ab 4.	T-12022	220798-UR	Shield 65/85/105A, Gouging	1	b 17.	T-11840	220990-UR	Nozzle 105A	5
b 5.	T-11841	220992-UR	Shield 105A, Hand	1	18.	T-11845	220930	Nozzle 45A, FC	5
b 6.	T-11842	220993-UR	Shield 105A, Machine	1	c 19.	T-11861	220857-UR	Swirl Ring 45-85A	1
7.	T-12013	220931	Deflector 45A, FC	1	c 20.	T-11930	220994-UR	Swirl Ring 105A	1
8.	T-12014	220948	Shield 45A, Ohmic, FC	1	c 21.	T-12015	220947-UR	Swirl Ring 45A, FC	1
d 9.	T-11423	220854-UR	Retaining Cap 45/65/85A	1	c 22.	T-11883	220842x5	Electrode 45-105A (pkg. 5 pcs.)	1 x 5
d 10.	T-11931	220953-UR	Retaining Cap 45/65/85A, Ohmic	1			220842	Part is available in 5pcs. set 220842x5 only	
b 11.	T-11422	T-11422	Retaining Cap 105A	1	23.			Set of Torch and Handle	1
b 12.	T-11932	T-11932	Retaining Cap 105A, Ohmic	1	24.	T-12187	T-12187	Box with Parts POWERMAX® 65/85/105	1
a 13.	T-11378	220941-UR	Nozzle 45A	5	25.	T-12188	T-12188	Empty Box POWERMAX® 65/85/105	1

- a** MUST BE USED ONLY AS A SET OF SHIELD AND NOZZLE, THIS COMPLETE SET IS INTERCHANGEABLE AND COMPATIBLE WITH ORIGINAL PARTS.
- b** MUST BE USED ONLY AS A SET OF SHIELD, RETAINING CAP AND NOZZLE, THIS COMPLETE SET IS INTERCHANGEABLE AND COMPATIBLE WITH ORIGINAL PARTS.
- c** MUST BE USED ONLY AS A SET OF ELECTRODE AND SWIRL RING, THIS COMPLETE SET IS INTERCHANGEABLE AND COMPATIBLE WITH ORIGINAL PARTS. ELECTRODES ARE PACKED TOGETHER WITH SWIRL RING SPRING HOLDER (BLACK PART) IN RATIO 5 ELECTRODES TO 1 HOLDER.
- d** RETAINING CAP UP TO 85A. FOR 105A - RETAINING CAP T-11422 HAS TO BE USED. DIFFERENT RETAINING CAP HAS TO BE USED FOR 105A AND FOR 45/65/85A. (19C), (20C) - ALSO POSSIBLE TO USE WITH FC CONFIGURATION, BUT FOR BEST CUT QUALITY RESULTS - USE 220947-UR.

SMART SOLUTION - DESIGN IMPROVEMENTS THAT BRINGS ADDED VALUE SUCH AS IMPROVED LIFETIME OF CONSUMABLES, EXCELLENT CUT QUALITY, SPEED OR BETTER COST EFFECTIVENESS OF YOUR SYSTEM.

THERMACUT®, FHT-EX® AND EX-TRAFIRE® ARE REGISTERED TRADEMARKS OF THERMACUT, K. S. AND MAY BE REGISTERED IN CZECH REPUBLIC AND/OR OTHER COUNTRIES. ALL OTHER TRADEMARKS ARE PROPERTIES OF THEIR RESPECTIVE OWNERS. THERMACUT IS NO WAY AFFILIATED WITH HYPERTHERM®. MOST THERMACUT PARTS ARE MADE FOR OR BY AN IBG COMPANY. PARTS INDICATED WITH A OEM ARE ORIGINAL PARTS MANUFACTURED BY THE ABOVE NAMED MANUFACTURER AND ARE BEING RESOLD BY THERMACUT. THERMACUT RESERVES THE RIGHT TO SUBSTITUTE OEM PARTS IN PLACE OF THERMACUT PARTS. VALID FROM SEPTEMBER 2024 • PREVIOUS VERSION IS NO LONGER VALID. • © COPYRIGHT 2024 BY THERMACUT® CZECH REPUBLIC. ALL RIGHTS RESERVED.

DEFINITIONS OF SUFFIXES, SYMBOLS & ABBREVIATIONS

SUFFIXES

OEM - Original Equipment Manufacturer (Original parts) - The original manufacturer of a particular part being resold by Thermacut.

UR - Unique Replacement - Thermacut company suffix - These products are fully interchangeable with original parts (OEM) but differ from original design. Sometimes it is necessary to use these parts in combination with other - UR parts.

AG - ARGENTUM - Silver / Heavy duty electrode, made from a silver alloy of high purity.

PRO - SILVER PRO technology (Silver insert in the copper electrode) - Combines advantages of both silver and copper electrodes, significantly increasing electrode life compared to the standard copper electrode while maintaining a reasonable price.

ABBREVIATIONS

MS - MILD STEEL

SS - STAINLESS STEEL

AL - Aluminum and its alloys

CC - CENTRAL CONNECTOR

Q.D. - QUICK DISCONNECT

W/ - WITH

W/O - WITHOUT

NS - NOT SHOWN IN THE PICTURE

CW/CCW - CLOCK WISE / COUNTER CLOCK WISE gas swirling

!EP - Planned End of Production at shown date - part will not be available after this date.

SYMBOLS

***/**/#/##** - Symbols used in the catalog as the explanatory note.

a b c d - These symbols always point to the part/s which must be used only as a set with other specific part/s.

(i)/(ii) - Information about limited distributing of marked part on specific market.

! - Ohmic contact wire is not part of the cable leads.

!!! - Demo is inoperative, for exhibition purposes only!

SMART SOLUTION - Design improvements that bring added value such as improved life of consumables, excellent cut quality, greater speed, or more cost effective solutions.

MIG/TIG WELDING



THERMACUT® REPLACEMENT PARTS SUITABLE FOR BERNARD® Q GUN 300A GUN

Item	Part No.	Description	Std. Pkg.	Item	Part No.	Description	Std. Pkg.
1.	4235	Gas Diffuser	5	6.	1880155	Handle Kit w/Screws (300A)	1
	4335	Gas Diffuser	5	7.	25BK-B	Block (300A)	1
2.	7488	Contact Tip, .030	25	8.	1840031	Insulator	1
	7489	Contact Tip, .035	25	9.	1840057	Nut Cover & Insulation Ring	1
	7490	Contact Tip, .045	25	10.	1790002	Hanger Hook	1
	7491	Contact Tip, 1/16"	25	11.	5662	Trigger Switch	1
	7498	Contact Tip, .052	25	12.	QT2-45	Swan Neck (300A)	1
	1589	Contact Tip, .035	25	13.	25MA	Trigger Connector, Miller® Style	1
	1590	Contact Tip, .045	25	14.	25LA	Trigger Connector, Lincoln® Style	1
	1598	Contact Tip, .052	25	15.	25SR	Rear Strain Relief (300A)	1
	1591	Contact Tip, 1/16"	25	16.	25CH	Plug Housing	1
	4281	Contact Tip, .035	25	17.	25RR	Retaining Ring	1
	4282	Contact Tip, .045	25	18.	25CBR	Connector Body	1
3.	4391	Nozzle Brass, 5/8"	5	19.	25CW	Stop Washer	1
	4392	Nozzle Tapered Brass, 1/2"	5	20.	25CR	Connector Ring	1
	4393	Nozzle Copper, 5/8"	5	21.	40TC-TR	Connector, Tweco® Style, for L-series Liners	1
	4394	Nozzle Tapered Copper, 1/2"	5	22.	40MCB	Connector, Miller® Style, for L-series Liners	1
	4295	Nozzle Tapered Brass, 3/8"	5	23.	L3A-15	Liner, .035 x .045, 15'	1
4.	4323R	Cap, 200,350	5		L3A-25	Liner, .035 x .035, 25'	1
5.	2520042-S	Handle Strain Relief (300A)	1	24.	25PC	Power Cable, 15'	1

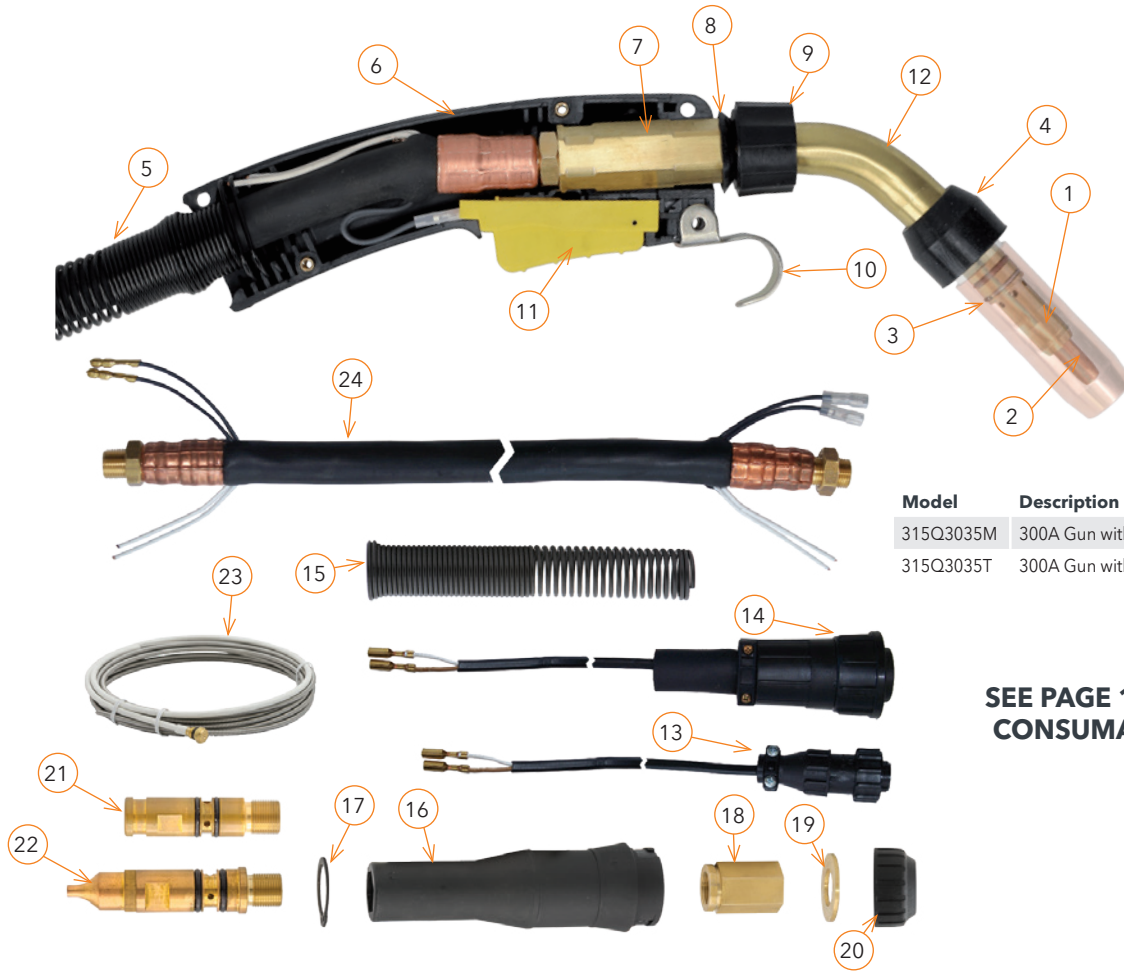

Model	Description
315Q3035M	300A Gun with 15' Cable, .030"-.035", Miller® Plug
315Q3035T	300A Gun with 15' Cable, .030"-.035", Tweco® Plug

**SEE PAGE 145 FOR MORE
CONSUMABLE OPTIONS**

THERMACUT®, FHT-EX® AND EX-TRAFIRE® ARE REGISTERED TRADEMARKS OF THERMACUT, K. S. AND MAY BE REGISTERED IN CZECH REPUBLIC AND/OR OTHER COUNTRIES. ALL OTHER TRADEMARKS ARE PROPERTIES OF THEIR RESPECTIVE OWNERS. THERMACUT IS NO WAY AFFILIATED WITH BERNARD®. MOST THERMACUT PARTS ARE MADE FOR OR BY AN IBG COMPANY. PARTS INDICATED WITH A OEM ARE ORIGINAL PARTS MANUFACTURED BY THE ABOVE NAMED MANUFACTURER AND ARE BEING RESOLD BY THERMACUT. THERMACUT RESERVES THE RIGHT TO SUBSTITUTE OEM PARTS IN PLACE OF THERMACUT PARTS. VALID FROM SEPTEMBER 2024 • PREVIOUS VERSION IS NO LONGER VALID. • © COPYRIGHT 2024 BY THERMACUT® CZECH REPUBLIC. ALL RIGHTS RESERVED.

THERMACUT® REPLACEMENT PARTS SUITABLE FOR BERNARD® Q GUN 300A GUN

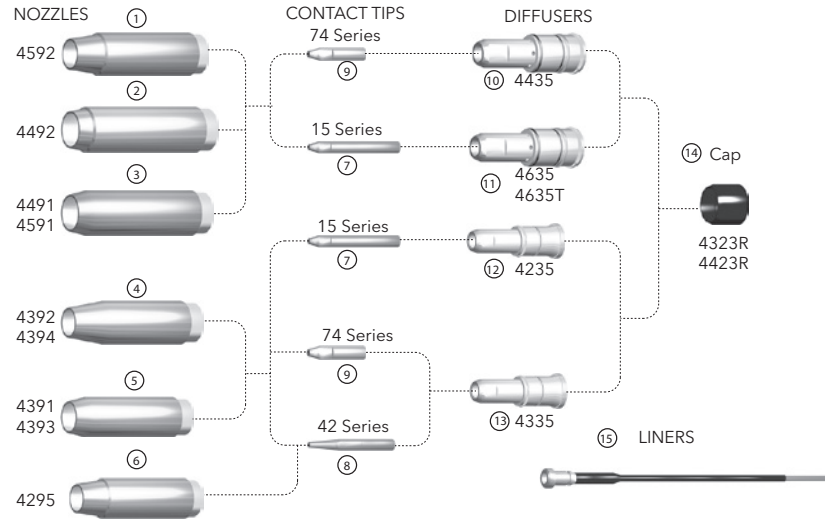

Item	Part No.	Description	Std. Pkg	Item	Part No.	Description	Std. Pkg
1.	4592	Nozzle Copper, 1/2"	5	NS	T-039	Contact Tip .039	25
2.	4492	Nozzle Tapered Brass, 5/8"	5	NS	T-045	Contact Tip .045	25
3.	4491	Nozzle Brass, 3/4"	5	NS	T--047	Contact Tip .047	25
	4591	Nozzle Copper, 3/4"	5	NS	T-052	Contact Tip .052	25
4.	4392	Nozzle Tapered Brass, 1/2"	5	NS	T-062	Contact Tip 1/16	25
	4394	Nozzle Tapered Copper, 1/2"	5	NS	T-078	Contact Tip 5/64	25
5.	4391	Nozzle Brass, 5/8"	5	NS	T-094	Contact Tip 3/32	25
	4393	Nozzle Copper, 5/8"	5	NS	TT-030	Contact Tip, Tapered, .030	25
6.	4295	Nozzle Tapered Brass, 3/8"	5	NS	TT-035	Contact Tip, Tapered, .035	25
7.	1589	Contact Tip, .035	25	NS	TT-039	Contact Tip, Tapered, .039	25
	1590	Contact Tip, .045	25	NS	TT-045	Contact Tip, Tapered, .045	25
	1598	Contact Tip, .052	25	NS	TT-052	Contact Tip, Tapered, .052	25
	1591	Contact Tip, 1/16"	25	NS	TT-062	Contact Tip, Tapered, 1/16	25
8.	4281	Contact Tip, .035	25	NS	DS-1	Gas Diffuser	5
	4282	Contact Tip, .045	25	NS	D-1	Gas Diffuser	5
9.	7488	Contact Tip, .030	25	NS	10012	Insulator	5
	7489	Contact Tip, .035	25	NS	NS-1200B	Nozzle 1/2, Flush Brass	5
	7490	Contact Tip, .045	25	NS	NS-1218B	Nozzle 1/2, 1/8 Rec., Brass	5
	7491	Contact Tip, 1/16"	25	NS	NS-1218C	Nozzle 1/2, 1/8 Rec., Copper	5
	7498	Contact Tip, .052	5	NS	NS-5800B	Nozzle 5/8, Flush Brass	5
10.	4435	Gas Diffuser +	5	NS	NS-5800C	Nozzle 5/8, Flush Copper	5
11.	4635	Gas Diffuser	5	NS	NS-5818B	Nozzle 5/8, 1/8 Rec., Brass	5
12.	4235	Gas Diffuser	5	NS	NS-5818C	Nozzle 5/8, 1/8 Rec., Copper	5
13.	4335	Gas Diffuser	5	NS	NST-3800B	Nozzle 3/8 Tapered, Flush, Brass	5
14.	4323R	Cap, 200,350	5	NS	NST-3818B	Nozzle 3/8 Tapered, 1/8 Rec., Brass	5
	4423R	Cap, 500	5	NS	NST-38XTB	Nozzle 3/8 Tapered, 1/8 Ext, Brass	5
15.	43015	Liner 15', .023 - .030(200A)	1	NS	N-5800B	Nozzle 5/8, Flush Brass	5
	43115	Liner 15', .035 - .045(200A)	1	NS	N-5800C	Nozzle 5/8, Flush Copper	5
	43215	Liner 15' 1/16" (200A)	1	NS	N-5818C	Nozzle 5/8, 1/8 Rec., Copper	5
	44115	Liner 15', .035-.045	1	NS	N-5818B	Nozzle 5/8, 1/8 Rec., Brass	5
	44125	Liner 25', .035-.045	1	NS	N-5814B	Nozzle 5/8, 1/4 Rec., Brass	5
	44215	Liner 15', 1/16"	1	NS	N-5814C	Nozzle 5/8, 1/4 Rec., Copper	5
	45415	Liner S 15', 3/32" (500A)	1	NS	N-3400B	Nozzle 3/4, Flush Brass	5
	44225	Liner .045 - .062, 25'	1	NS	N-3400C	Nozzle 3/4, Flush Copper	5
NS	4422BE	Trigger Switch	1	NS	N-3418B	Nozzle 3/4, 1/8 Rec., Brass	5
NS	4780	Neck Insulator	1	NS	N-3418C	Nozzle 3/4, 1/8 Rec., Copper	5
NS	5662	Trigger Switch	1	NS	N-3414B	Nozzle 3/4, 1/4 Rec., Brass	5
NS	4790	Swan Neck	1	NS	N-3414C	Nozzle 3/4, 1/4 Rec., Copper	5
NS	4786	Swan Neck	1	NS	NT-3800C	Nozzle 3/8, Flush, Copper	5
NS	4794	Swan Neck	1				
NS	T-030	Contact Tip .030	25				
NS	T-035	Contact Tip .035	25				

THERMACUT®, FHT-EX® AND EX-TRAFIRE® ARE REGISTERED TRADEMARKS OF THERMACUT, K. S. AND MAY BE REGISTERED IN CZECH REPUBLIC AND/OR OTHER COUNTRIES. ALL OTHER TRADEMARKS ARE PROPERTIES OF THEIR RESPECTIVE OWNERS. THERMACUT IS NO WAY AFFILIATED WITH BERNARD®. MOST THERMACUT PARTS ARE MADE FOR OR BY AN IBG COMPANY. PARTS INDICATED WITH A OEM ARE ORIGINAL PARTS MANUFACTURED BY THE ABOVE NAMED MANUFACTURER AND ARE BEING RESOLD BY THERMACUT. THERMACUT RESERVES THE RIGHT TO SUBSTITUTE OEM PARTS IN PLACE OF THERMACUT PARTS. VALID FROM SEPTEMBER 2024 • PREVIOUS VERSION IS NO LONGER VALID. • © COPYRIGHT 2024 BY THERMACUT® CZECH REPUBLIC. ALL RIGHTS RESERVED.

THERMACUT® REPLACEMENT PARTS SUITABLE FOR BERNARD® Q GUN 400A GUN

Item	Part No.	Description	Std. Pkg.	Item	Part No.	Description	Std. Pkg.
1.	4435	Gas Diffuser	5	7.	1840031	Insulator	1
	4635	Gas Diffuser	5	8.	1840057	Nut Cover & Insulation Ring	1
2.	7488	Contact Tip, .030	25	9.	1790002	Hanger Hook	1
	7489	Contact Tip, .035	25	10.	5662	Trigger Switch	1
	7490	Contact Tip, .045	25	11.	QT3-45	Swan Neck (400A)	1
	7491	Contact Tip, 1/16"	25	12.	25MA	Trigger Connector, Miller® Style	1
	7498	Contact Tip, .052	25	13.	25LA	Trigger Connector, Lincoln® Style	1
	1589	Contact Tip, .035	25	14.	25CH	Plug Housing	1
	1590	Contact Tip, .045	25	15.	25RR	Retaining Ring	1
	1598	Contact Tip, .052	25	16.	40CBR	Connector Body	1
	1591	Contact Tip, 1/16"	25	17.	40CW	Stop Washer	1
3.	4491	Nozzle Brass, 3/4"	5	18.	40TC-TR	Connector, Tweco® Style, for L-series Liners	1
	4492	Nozzle Tapered Brass, 5/8"	5	19.	40MCB	Connector, Miller® Style, for L-series Liners	1
	4591	Nozzle Copper, 3/4"	5	20.	L4A-15	Liner, .045 x 1/16, 15'	1
	4592	Nozzle Copper, 1/2"	5		L4A-25	Liner, .045 x 1/16, 25'	1
4.	4423R	Cap, 400	5	21.	40PC-B	Power Cable, 15'	1
5.	1880198	Handle Kit w/Screws (400A)	1				
6.	40BK-B	Block (400A)	1				

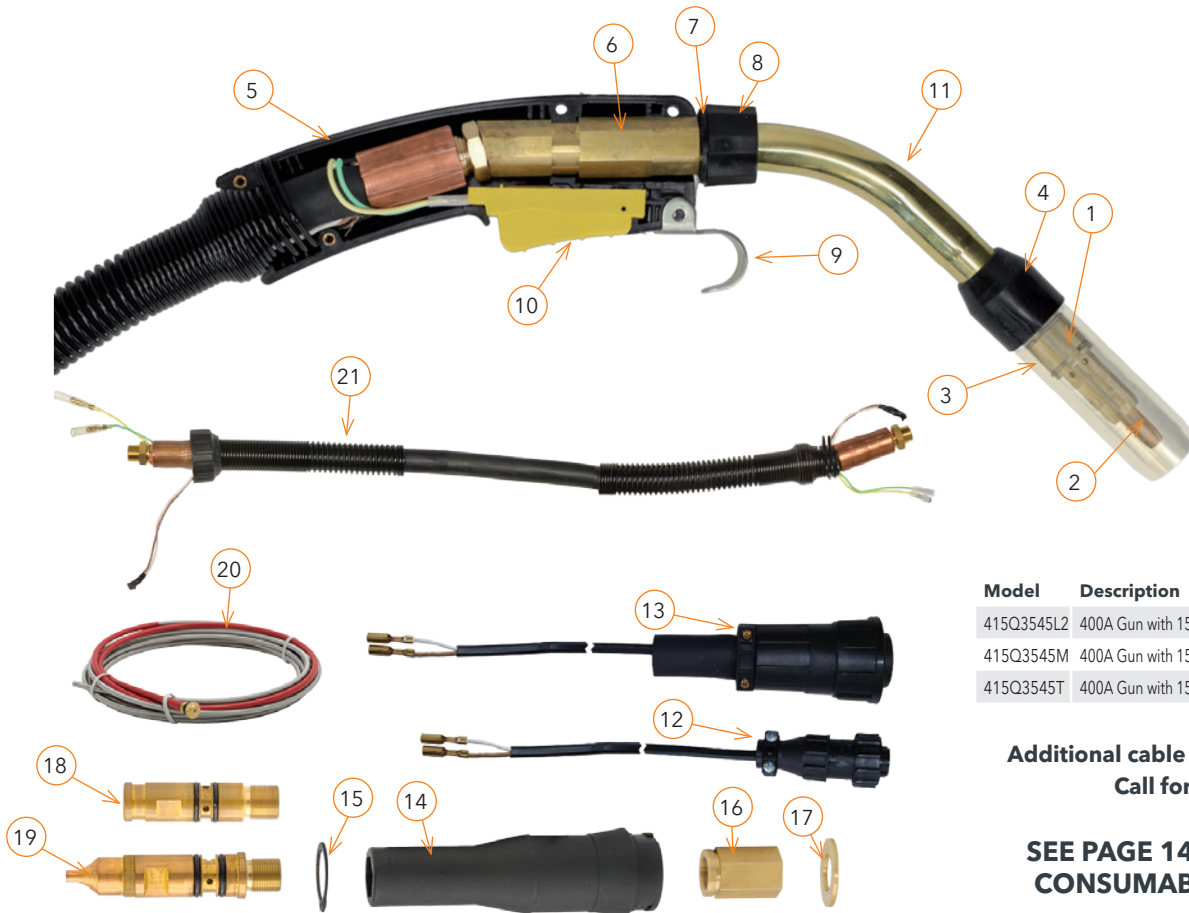

Model	Description
415Q3545L2	400A Gun with 15' Cable, .035" - .045", Lincoln® Plug
415Q3545M	400A Gun with 15' Cable, .035" - .045", Miller® Plug
415Q3545T	400A Gun with 15' Cable, .035" - .045", Tweco® Plug

**Additional cable lengths available.
Call for details.**

**SEE PAGE 147 FOR MORE
CONSUMABLE OPTIONS**

THERMACUT®, FHT-EX® AND EX-TRAFIRE® ARE REGISTERED TRADEMARKS OF THERMACUT, K. S. AND MAY BE REGISTERED IN CZECH REPUBLIC AND/OR OTHER COUNTRIES. ALL OTHER TRADEMARKS ARE PROPERTIES OF THEIR RESPECTIVE OWNERS. THERMACUT IS NO WAY AFFILIATED WITH BERNARD®. MOST THERMACUT PARTS ARE MADE FOR OR BY AN IBG COMPANY. PARTS INDICATED WITH A OEM ARE ORIGINAL PARTS MANUFACTURED BY THE ABOVE NAMED MANUFACTURER AND ARE BEING RESOLD BY THERMACUT. THERMACUT RESERVES THE RIGHT TO SUBSTITUTE OEM PARTS IN PLACE OF THERMACUT PARTS. VALID FROM SEPTEMBER 2024 • PREVIOUS VERSION IS NO LONGER VALID. • © COPYRIGHT 2024 BY THERMACUT® CZECH REPUBLIC. ALL RIGHTS RESERVED.

THERMACUT® REPLACEMENT PARTS SUITABLE FOR BERNARD® Q GUN 400A GUN

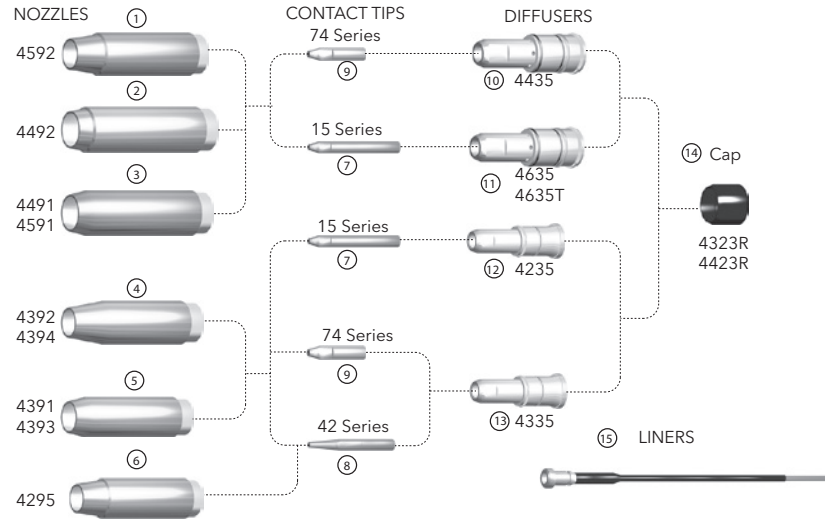

Item	Part No.	Description	Std. Pkg	Item	Part No.	Description	Std. Pkg
1.	4592	Nozzle Copper, 1/2"	5	NS T-039	Contact Tip .039	25	
2.	4492	Nozzle Tapered Brass, 5/8"	5	NS T-045	Contact Tip .045	25	
3.	4491	Nozzle Brass, 3/4"	5	NS T-.047	Contact Tip .047	25	
	4591	Nozzle Copper, 3/4"	5	NS T-052	Contact Tip .052	25	
4.	4392	Nozzle Tapered Brass, 1/2"	5	NS T-062	Contact Tip 1/16	25	
	4394	Nozzle Tapered Copper, 1/2"	5	NS T-078	Contact Tip 5/64	25	
5.	4391	Nozzle Brass, 5/8"	5	NS T-094	Contact Tip 3/32	25	
	4393	Nozzle Copper, 5/8"	5	NS TT-030	Contact Tip, Tapered, .030	25	
6.	4295	Nozzle Tapered Brass, 3/8"	5	NS TT-035	Contact Tip, Tapered, .035	25	
7.	1589	Contact Tip, .035	25	NS TT-039	Contact Tip, Tapered, .039	25	
	1590	Contact Tip, .045	25	NS TT-045	Contact Tip, Tapered, .045	25	
	1598	Contact Tip, .052	25	NS TT-052	Contact Tip, Tapered, .052	25	
	1591	Contact Tip, 1/16"	25	NS TT-062	Contact Tip, Tapered, 1/16	25	
8.	4281	Contact Tip, .035	25	NS DS-1	Gas Diffuser	5	
	4282	Contact Tip, .045	25	NS D-1	Gas Diffuser	5	
9.	7488	Contact Tip, .030	25	NS 10012	Insulator	5	
	7489	Contact Tip, .035	25	NS NS-1200B	Nozzle 1/2, Flush Brass	5	
	7490	Contact Tip, .045	25	NS NS-1218B	Nozzle 1/2, 1/8 Rec., Brass	5	
	7491	Contact Tip, 1/16"	25	NS NS-1218C	Nozzle 1/2, 1/8 Rec., Copper	5	
	7498	Contact Tip, .052	5	NS NS-5800B	Nozzle 5/8, Flush Brass	5	
10.	4435	Gas Diffuser +	5	NS NS-5800C	Nozzle 5/8, Flush Copper	5	
	4635	Gas Diffuser	5	NS NS-5818B	Nozzle 5/8, 1/8 Rec., Brass	5	
11.	4635	Gas Diffuser	5	NS NS-5818C	Nozzle 5/8, 1/8 Rec., Copper	5	
12.	4235	Gas Diffuser	5	NS NST-3800B	Nozzle 3/8 Tapered, Flush, Brass	5	
13.	4335	Gas Diffuser	5	NS NST-3818B	Nozzle 3/8 Tapered, 1/8 Rec., Brass	5	
14.	4323R	Cap, 200,350	5	NS NST-38XTB	Nozzle 3/8 Tapered, 1/8 Ext, Brass	5	
	4423R	Cap, 500	5	NS N-5800B	Nozzle 5/8, Flush Brass	5	
15.	43015	Liner 15', .023 -.030(200A)	1	NS N-5800C	Nozzle 5/8, Flush Copper	5	
	43115	Liner 15', .035 -.045(200A)	1	NS N-5818C	Nozzle 5/8, 1/8 Rec., Copper	5	
	43215	Liner 15' 1/16" (200A)	1	NS N-5818B	Nozzle 5/8, 1/8 Rec., Brass	5	
	44115	Liner 15', .035-.045	1	NS N-5814B	Nozzle 5/8, 1/4 Rec., Brass	5	
	44125	Liner 25', .035-.045	1	NS N-5814C	Nozzle 5/8, 1/4 Rec., Copper	5	
	44215	Liner 15', 1/16"	1	NS N-3400B	Nozzle 3/4, Flush Brass	5	
	45415	Liner S 15', 3/32" (500A)	1	NS N-3400C	Nozzle 3/4, Flush Copper	5	
	44225	Liner .045 - .062, 25'	1	NS N-3418B	Nozzle 3/4, 1/8 Rec., Brass	5	
NS	4422BE	Trigger Switch	1	NS N-3418C	Nozzle 3/4, 1/8 Rec., Copper	5	
NS	4780	Neck Insulator	1	NS N-3414B	Nozzle 3/4, 1/4 Rec., Brass	5	
NS	5662	Trigger Switch	1	NS N-3414C	Nozzle 3/4, 1/4 Rec., Copper	5	
NS	4790	Swan Neck	1	NS NT-3800C	Nozzle 3/8, Flush, Copper	5	
NS	4786	Swan Neck	1				
NS	4794	Swan Neck	1				
NS	T-030	Contact Tip .030	25				
NS	T-035	Contact Tip .035	25				

THERMACUT®, FHT-EX® AND EX-TRAFIRE® ARE REGISTERED TRADEMARKS OF THERMACUT, K. S. AND MAY BE REGISTERED IN CZECH REPUBLIC AND/OR OTHER COUNTRIES. ALL OTHER TRADEMARKS ARE PROPERTIES OF THEIR RESPECTIVE OWNERS. THERMACUT IS NO WAY AFFILIATED WITH BERNARD®. MOST THERMACUT PARTS ARE MADE FOR OR BY AN IBG COMPANY. PARTS INDICATED WITH A OEM ARE ORIGINAL PARTS MANUFACTURED BY THE ABOVE NAMED MANUFACTURER AND ARE BEING RESOLD BY THERMACUT. THERMACUT RESERVES THE RIGHT TO SUBSTITUTE OEM PARTS IN PLACE OF THERMACUT PARTS. VALID FROM SEPTEMBER 2024 • PREVIOUS VERSION IS NO LONGER VALID. • © COPYRIGHT 2024 BY THERMACUT® CZECH REPUBLIC. ALL RIGHTS RESERVED.

THERMACUT® REPLACEMENT PARTS SUITABLE FOR MILLER® GUN 160A GUN

Item	Part No.	Description	Std. Pkg.	Item	Part No.	Description	Std. Pkg.
1.	169-716	Gas Diffuser	5	10.	13BK	Tube Block	1
2.	087-299	Contact Tip .023	25	11.	13CTM	Swan Neck (160A)	1
	000-067	Contact Tip .030	25	12.	25MA	Trigger Connector, Miller® Style	1
	000-068	Contact Tip .035	25	13.	13CA	Plug Housing	1
	000-069	Contact Tip .045	25	14.	13SRR	Strain Relief (160A)	1
3.	169-715	Nozzle 1/2" Flush	5	15.	13SW	Stop Washer	1
4.	13SR	Strain Relief (160A)	1	16.	13MCM	Connector, Miller® Style, for Miller Liners	1
5.	25HR	Locking Ring (160A)	1	17.	194010	Liner, .023 x .025, 15'	1
6.	13HD	Handle Kit /w Screws (160A)	1		194011	Liner, .030 x .035, 15'	1
7.	25GH	Hanger Hook	1		194012	Liner, .035 x .045, 15'	1
8.	25TB	Trigger Blade	1	18.	13PC	Power Cable, 10'	1
9.	25TR	Trigger Switch	1		13PC15	Power Cable, 15'	1

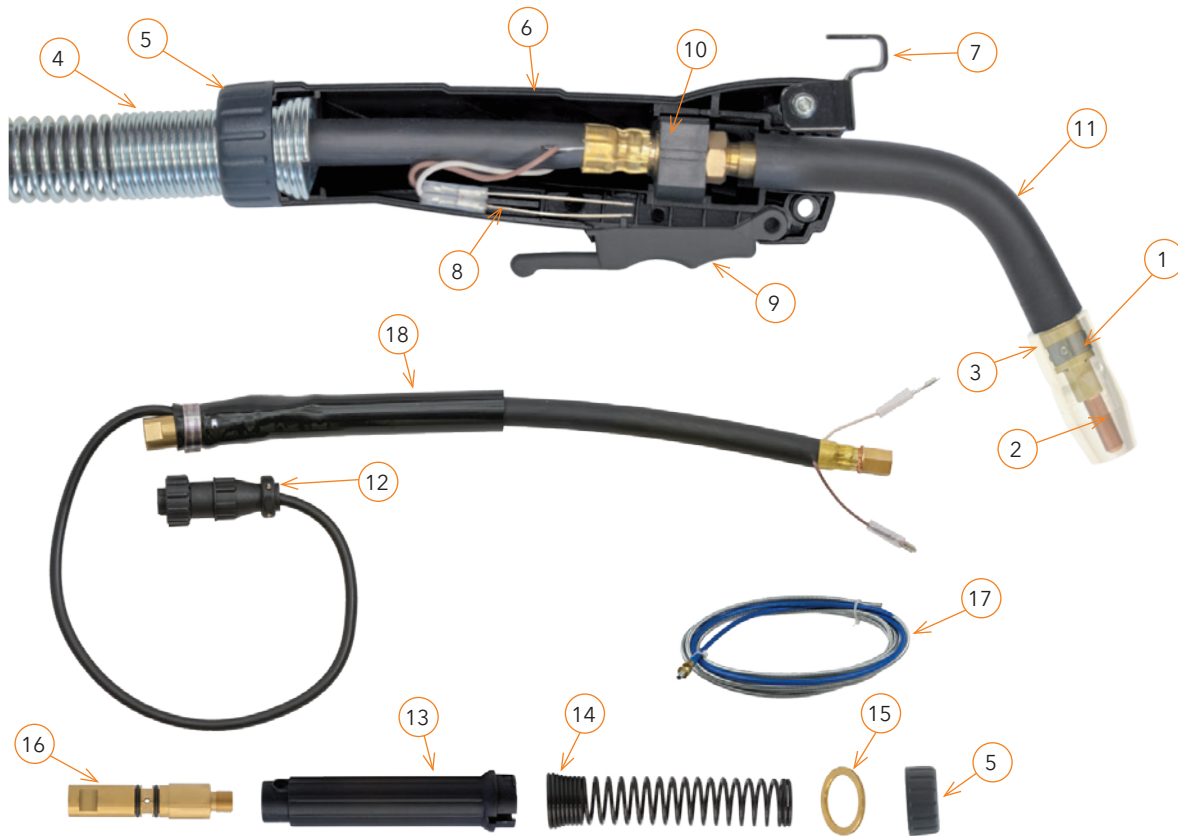

Model	Description
135M103035M	160A Miller® Gun with 10' Cable, .030" - .035", Miller® Plug
135M153035M	160A Tweco® Gun with 15' Cable, .030" - .035", Miller® Plug
135M153545M	160A Tweco® Gun with 15' Cable, .035" - .045", Euro Plug

**SEE PAGE 149 FOR MORE
CONSUMABLE OPTIONS**

Additional cable lengths available. Call for details.

THERMACUT®, FHT-EX® AND EX-TRAFIRE® ARE REGISTERED TRADEMARKS OF THERMACUT, K. S. AND MAY BE REGISTERED IN CZECH REPUBLIC AND/OR OTHER COUNTRIES. ALL OTHER TRADEMARKS ARE PROPERTIES OF THEIR RESPECTIVE OWNERS. THERMACUT IS NO WAY AFFILIATED WITH MILLER®. MOST THERMACUT PARTS ARE MADE FOR OR BY AN IBG COMPANY. PARTS INDICATED WITH A OEM ARE ORIGINAL PARTS MANUFACTURED BY THE ABOVE NAMED MANUFACTURER AND ARE BEING RESOLD BY THERMACUT. THERMACUT RESERVES THE RIGHT TO SUBSTITUTE OEM PARTS IN PLACE OF THERMACUT PARTS.
VALID FROM SEPTEMBER 2024 • PREVIOUS VERSION IS NO LONGER VALID. • © COPYRIGHT 2024 BY THERMACUT® CZECH REPUBLIC. ALL RIGHTS RESERVED.

THERMACUT® REPLACEMENT PARTS SUITABLE FOR MILLER® GUN SPOOLMATIC® 1, 2, 3 GUNS

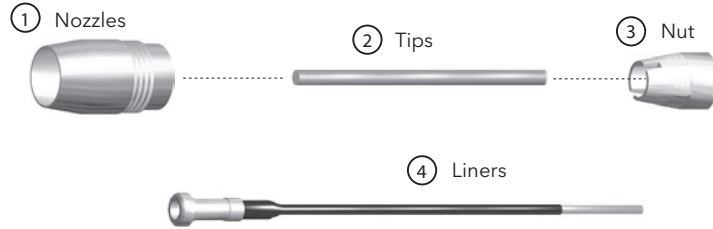

Item	Part No.	Description	Std. Pkg.	Item	Part No.	Description	Std. Pkg.
1.	050-115	Nozzle 1/2"	5		135-428	Contact Tip .030	25
2.	135-425	Contact Tip .062	25		135-429	Contact Tip .047	25
	135-424	Contact Tip .047	25		135-430	Contact Tip .035	25
	050-638	Contact Tip .030	25	3.	058-676	Brass Nut	5
	094-259	Contact Tip .035	25	4.	136-683	Liner, PTFE .045 7" Lg	10
	094-260	Contact Tip 3/64"	25				

THERMACUT® REPLACEMENT PARTS SUITABLE FOR M15, M25/25M, M40/40AL GUNS

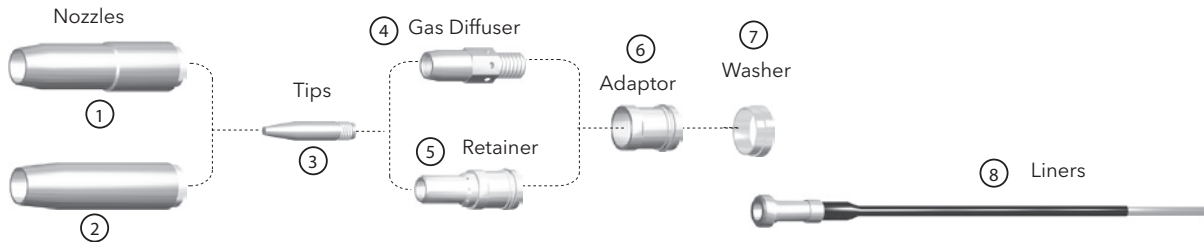

Item	Part No.	Description	Std. Pkg.	Item	Part No.	Description	Std. Pkg.
1.	169-715	Nozzle 1/2" Flush	5	NS	206186	Contact Tip .035 Steel & .030 AL	25
2.	169-724	Nozzle 1/2", 1/8 Recess	5	NS	206187	Contact Tip .040 Steel & .035 AL	25
	169-725	Nozzle 5/8", 1/8 Recess	5	NS	206188	Contact Tip .045 Steel & .040 AL	25
	169-726	Nozzle 5/8", Flush	5	NS	206189	Contact Tip .052 Steel & 3/64 AL	25
	169-727	Nozzle 5/8", 1/8" Stick-Out	25	NS	206191	Contact Tip .035 Steel & .030 AL	25
3.	000-067	Contact Tip .030	5	NS	209026	Contact Tip .035 Steel & .030 AL	25
	000-068	Contact Tip .035	25	NS	209027	Contact Tip .035 Steel & .030 AL	25
	000-069	Contact Tip .045	25	NS	209029	Contact Tip .068 Steel	25
	087-299	Contact Tip .025	25	NS	199610	Nozzle 1/2", Brass	5
	172-024	Contact Tip 1/16" SCR	25	NS	199611	Nozzle 3/4" Brass	5
4.	169-728	Gas Diffuser	5	NS	199612	Nozzle 3/4", Heavy Duty Brass	5
5.	169-716	Retainer	5	NS	199613	Nozzle 5/8", Brass	5
6.	169-729	Nozzle Adaptor	5	NS	199614	Nozzle 5/8", Heavy Duty, Brass	5
7.	169-730	Shock Washer	5	NS	199615	Nozzle 1/2", Copper	5
8.	194010	Liner 15', .023-035	1	NS	199616	Nozzle 3/4", Copper	5
	194011	Liner 15', .030-035	1	NS	199617	Nozzle, 3/4" Heavy Duty, Copper	5
	194012	Liner 15', .035-045	1	NS	198855	Nozzle 5/8", Brass	5
	194013	Liner 15', 1/16-5/64"	1	NS	199618	Nozzle 5/8", Heavy Duty, Copper	5
NS	206195	Gas Diffuser, 1/8 Recess	5	NS	209035	Nozzle 3/8", Heavy Duty, Tapered	5
NS	206196	Gas Diffuser, Flush	5	NS	209036	Nozzle 1/2", Heavy Duty, Tapered	5
NS	227749	Gas Diffuser, 1/8 Recess	5				
NS	229670	Gas Diffuser, 1/8 Recess	5				

THERMACUT®, FHT-EX® AND EX-TRAFIRE® ARE REGISTERED TRADEMARKS OF THERMACUT, K. S. AND MAY BE REGISTERED IN CZECH REPUBLIC AND/OR OTHER COUNTRIES. ALL OTHER TRADEMARKS ARE PROPERTIES OF THEIR RESPECTIVE OWNERS. THERMACUT IS NO WAY AFFILIATED WITH MILLER®.

MOST THERMACUT PARTS ARE MADE FOR OR BY AN IBG COMPANY. PARTS INDICATED WITH A OEM ARE ORIGINAL PARTS MANUFACTURED BY THE ABOVE NAMED MANUFACTURER AND ARE BEING RESOLD BY THERMACUT. THERMACUT RESERVES THE RIGHT TO SUBSTITUTE OEM PARTS IN PLACE OF THERMACUT PARTS.

VALID FROM SEPTEMBER 2024 • PREVIOUS VERSION IS NO LONGER VALID. • © COPYRIGHT 2024 BY THERMACUT® CZECH REPUBLIC. ALL RIGHTS RESERVED.

THERMACUT® REPLACEMENT PARTS SUITABLE FOR MILLER® GUN 280A GUN

Item	Part No.	Description	Std. Pkg.	Item	Part No.	Description	Std. Pkg.
1.	169-728	Gas Diffuser	5	11.	25TR	Trigger Switch	1
2.	169-729	Retainer	5	12.	25BK	Tube Block	1
3.	087-299	Contact Tip .023	25	13.	25CTM	Swan Neck (280A)	1
	000-067	Contact Tip .030	25	14.	25MA	Trigger Connector, Miller® Style	1
	000-068	Contact Tip .035	25	15.	25CH	Plug Housing	1
	000-069	Contact Tip .045	25	16.	25RR	Retaining Ring	1
4.	169-724	Nozzle 1/2", 1/8" Recess	5	17.	25CBR	Connector Body	1
	169-725	Nozzle 5/8", 1/8" Recess	5	18.	25SW	Stop Washer	1
	169-726	Nozzle 5/8", Flush	5	19.	25CR	Connector Ring	1
	169-727	Nozzle 5/8", 1/8" Stick-Out	5	20.	25MCM	Connector, Miller® Style, for Miller Liners	1
5.	169-730	Insulator	5	21.	194010	Liner, .023 x .025, 15'	1
6.	25SR	Strain Relief (280A)	1		194011	Liner, .030 x .035, 15'	1
7.	25HR	Locking Ring (280A)	1		194012	Liner, .035 x .045, 15'	1
8.	25HD	Handle Kit /w Screws (250A)	1	22.	25PC	Power Cable, 15'	1
9.	25GH	Hanger Hook	1		25PC12	Power Cable, 12'	1
10.	25TB	Trigger Blade	1				

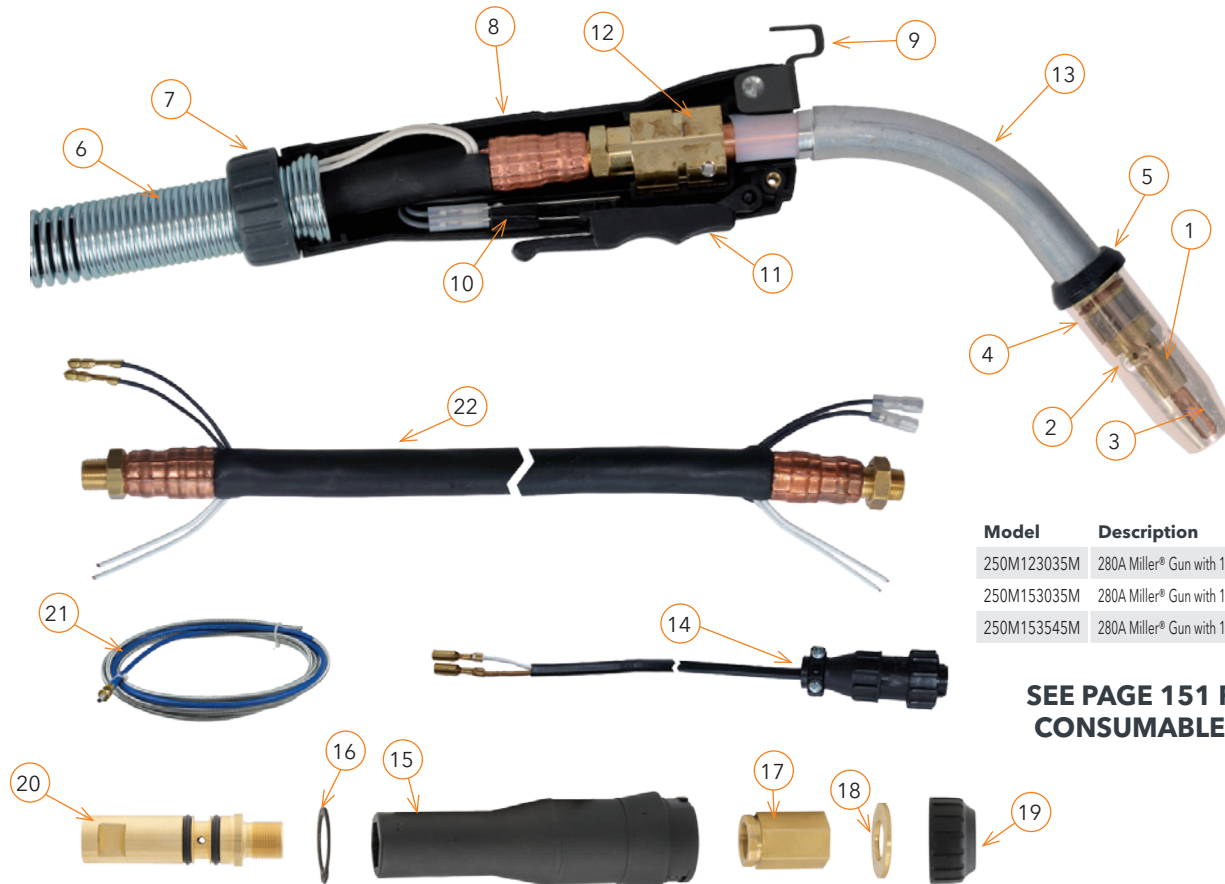

Model	Description
250M123035M	280A Miller® Gun with 12' Cable, .030" - .035", Miller® Plug
250M153035M	280A Miller® Gun with 15' Cable, .030" - .035", Miller® Plug
250M153545M	280A Miller® Gun with 15' Cable, .035" - .045", Miller® Plug

**SEE PAGE 151 FOR MORE
CONSUMABLE OPTIONS**

THERMACUT®, FHT-EX® AND EX-TRAFIRE® ARE REGISTERED TRADEMARKS OF THERMACUT, K. S. AND MAY BE REGISTERED IN CZECH REPUBLIC AND/OR OTHER COUNTRIES. ALL OTHER TRADEMARKS ARE PROPERTIES OF THEIR RESPECTIVE OWNERS. THERMACUT IS NO WAY AFFILIATED WITH MILLER®. MOST THERMACUT PARTS ARE MADE FOR OR BY AN IBG COMPANY. PARTS INDICATED WITH A OEM ARE ORIGINAL PARTS MANUFACTURED BY THE ABOVE NAMED MANUFACTURER AND ARE BEING RESOLD BY THERMACUT. THERMACUT RESERVES THE RIGHT TO SUBSTITUTE OEM PARTS IN PLACE OF THERMACUT PARTS. VALID FROM SEPTEMBER 2024 • PREVIOUS VERSION IS NO LONGER VALID. • © COPYRIGHT 2024 BY THERMACUT® CZECH REPUBLIC. ALL RIGHTS RESERVED.

THERMACUT® REPLACEMENT PARTS SUITABLE FOR MILLER® GUN SPOOLMATIC®, XR®, AND ROUGHNECK® GUNS

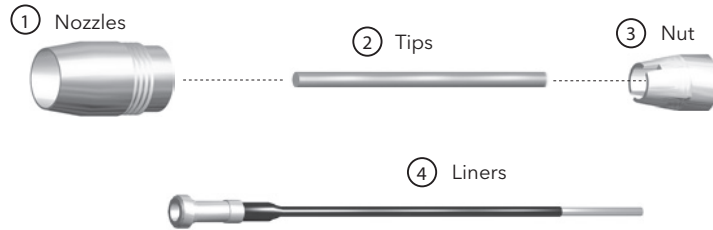

Item	Part No.	Description	Std. Pkg.	Item	Part No.	Description	Std. Pkg.
1.	050-115	Nozzle 1/2"	5		135-428	Contact Tip .030	25
2.	135-425	Contact Tip .062	25		135-429	Contact Tip .047	25
	135-424	Contact Tip .047	25		135-430	Contact Tip .035	25
	050-638	Contact Tip .030	25	3.	058-676	Brass Nut	5
	094-259	Contact Tip .035	25	4.	136-683	Liner, PTFE .045 7" Lg	10
	094-260	Contact Tip 3/64"	25				

THERMACUT® REPLACEMENT PARTS SUITABLE FOR M15, M25/25M, M40/40AL GUNS

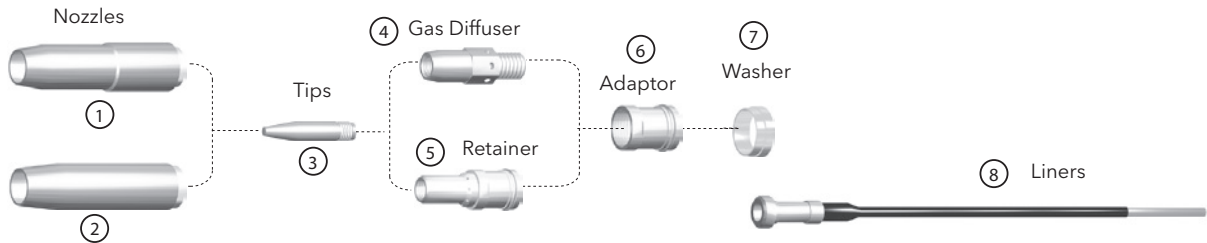

Item	Part No.	Description	Std. Pkg.	Item	Part No.	Description	Std. Pkg.
1.	169-715	Nozzle 1/2" Flush	5		194012	Liner 15', .035-.045	1
2.	169-724	Nozzle 1/2", 1/8 Recess	5		194013	Liner 15', 1/16-5/64"	1
	169-725	Nozzle 5/8", 1/8 Recess	5	NS	206195	Gas Diffuser, 1/8 Recess	5
	169-726	Nozzle 5/8", Flush	5	NS	206196	Gas Diffuser, Flush	5
	169-727	Nozzle 5/8", 1/8" Stick-Out	25	NS	227749	Gas Diffuser, 1/8 Recess	5
3.	000-067	Contact Tip .030	5	NS	229670	Gas Diffuser, 1/8 Recess	5
	000-068	Contact Tip .035	25	NS	206186	Contact Tip .035 Steel & .030 AL	25
	000-069	Contact Tip .045	25	NS	206187	Contact Tip .040 Steel & .035 AL	25
	087-299	Contact Tip .025	25	NS	206188	Contact Tip .045 Steel & .040 AL	25
	172-024	Contact Tip 1/16" SCR	25	NS	206189	Contact Tip .052 Steel & 3/64 AL	25
4.	169-728	Gas Diffuser	5	NS	206191	Contact Tip .035 Steel & .030 AL	25
5.	169-716	Retainer	5	NS	209026	Contact Tip .035 Steel & .030 AL	25
6.	169-729	Nozzle Adaptor	5	NS	209027	Contact Tip .035 Steel & .030 AL	25
7.	169-730	Shock Washer	5	NS	209029	Contact Tip .068 Steel	25
8.	194010	Liner 15', .023-.035	1	NS	199610	Nozzle 1/2", Brass	5
	194011	Liner 15', .030-.035	1				

THERMACUT®, FHT-EX® AND EX-TRAFIRE® ARE REGISTERED TRADEMARKS OF THERMACUT, K. S. AND MAY BE REGISTERED IN CZECH REPUBLIC AND/OR OTHER COUNTRIES. ALL OTHER TRADEMARKS ARE PROPERTIES OF THEIR RESPECTIVE OWNERS. THERMACUT IS NO WAY AFFILIATED WITH MILLER®. MOST THERMACUT PARTS ARE MADE FOR OR BY AN IBG COMPANY. PARTS INDICATED WITH A OEM ARE ORIGINAL PARTS MANUFACTURED BY THE ABOVE NAMED MANUFACTURER AND ARE BEING RESOLD BY THERMACUT. THERMACUT RESERVES THE RIGHT TO SUBSTITUTE OEM PARTS IN PLACE OF THERMACUT PARTS. VALID FROM SEPTEMBER 2024 • PREVIOUS VERSION IS NO LONGER VALID. • © COPYRIGHT 2024 BY THERMACUT® CZECH REPUBLIC. ALL RIGHTS RESERVED.

THERMACUT® REPLACEMENT PARTS SUITABLE FOR TREGASKISS® GUN 280A GUN

Item	Part No.	Description	Std. Pkg.	Item	Part No.	Description	Std. Pkg.
1.	404-3	Gas Diffuser/Retainer	5		401-6-75	Nozzle HD Insul. 3/4", 1/8" Recess	5
	404-13	Gas Diffuser/Retainer with Setscrew	5		401-6-62	Nozzle HD Insul. 5/8", 1/8" Recess	5
2.	403-35	Contact Tip .035	25	4.	402-5	Shock Washer HD	5
	403-45	Contact Tip .045	25	5.	25SR	Strain Relief (280A)	1
	403-52	Contact Tip .052	25	6.	25HR	Locking Ring (280A)	1
	403-116	Contact Tip 1/16	25	7.	25HD	Handle Kit /w Screws (250A)	1
	403-1-35	Contact Tip .035 HD	25	8.	25GH	Hanger Hook	1
	403-1-40	Contact Tip .040" HD	25	9.	25TB	Trigger Blade	1
	403-1-45	Contact Tip .045" HD	25	10.	25TR	Trigger Switch	1
	403-1-52	Contact Tip .052" HD	25	11.	25BK	Tube Block	1
	403-1-116	Contact Tip 1/16" HD	25	12.	25CTT	Swan Neck (280A)	1
	403-1-332	Contact Tip 3/32" HD	25	13.	25MA	Trigger Connector, Miller® Style	1
	403-2-35	Contact Tip Tapered .035	25	14.	25LA	Trigger Connector, Lincoln® Style	1
	403-2-45	Contact Tip Tapered .045	25	15.	25CH	Plug Housing	1
	403-3-35	Contact Tip HD Tapered .035	25	16.	25RR	Retaining Ring	1
	403-3-45	Contact Tip HD Tapered .045	25	17.	25CBR	Connector Body	1
	403-3-52	Contact Tip HD Tapered .052	25	18.	25CW	Stop Washer	1
	403-3-116	Contact Tip HD Tapered 1/16	25	19.	25CR	Connector Ring	1
3.	401-4-38	Nozzle Insul. 3/8", Flush	5	20.	40TC-TR	Connector, Tweco® Style, for L-series Liners	1
	401-4-50	Nozzle Insul. 1/2", 1/8" Recess	5	21.	40MCB	Connector, Miller® Style, for L-series Liners	1
	401-4-62	Nozzle Insul. 5/8", 1/8" Recess	5	22.	L3A-15	Liner, .035 x .045, 15'	1
	401-4-75	Nozzle Insul. 3/4", 1/8" Recess	5		L3A-25	Liner, .035 x .045, 25'	1
	401-5-62	Nozzle Insul. 5/8" HD	5	23.	25PC	Power Cable, 15'	1
	401-5-75	Nozzle Insul. 3/4" HD	5		25PC12	Power Cable, 12'	1

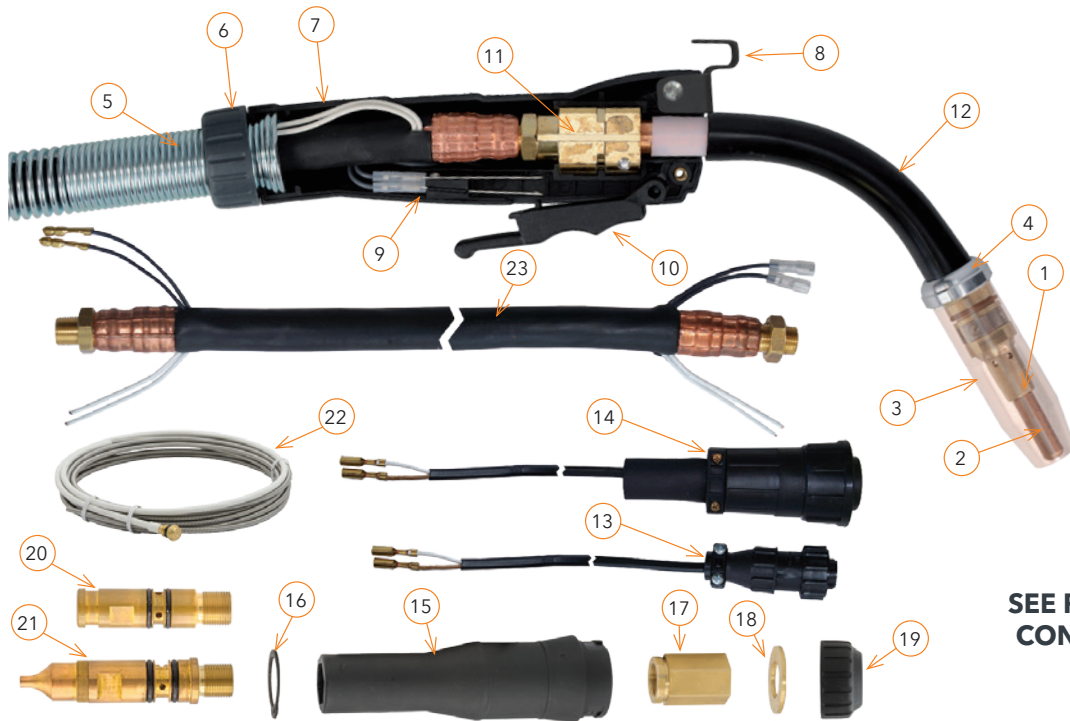

**SEE PAGE 153 FOR MORE
CONSUMABLE OPTIONS**

Model	Description	Model	Description
250TR153035TRT	280A TGK® Gun, 15' Cable, .030"-.035" L-Series liner, Tweco® Plug	250TR153545TRL	280A TGK® Gun, 15' Cable, .035"-.045" L-Series liner, Lincoln® Plug
250TR153545TRT	280A TGK® Gun, 15' Cable, .035"-.045" L-Series liner, Tweco® Plug	250TR153035TRL2	280A TGK® Gun, 15' Cable, .030"-.035" L-Series liner, Tweco®-Lincoln® Plug
250TR123035TRM	280A TGK® Gun, 12' Cable, .030"-.035" L-Series liner, Miller® Plug	250TR153545TRL2	280A TGK® Gun, 15' Cable, .035"-.045" L-Series liner, Tweco®-Lincoln® Plug
250TR153035TRM	280A TGK® Gun, 15' Cable, .030"-.035" L-Series liner, Miller® Plug	250TR153035E	280A TGK® Gun, 15' Cable, .030"-.035" Tweco® liner, Euro Plug
250TR153545TRM	280A TGK® Gun, 12' Cable, .035"-.045" L-Series liner, Miller® Plug	250TR153545E	280A TGK® Gun, 15' Cable, .035"-.045" Tweco® liner, Euro Plug
250TR153035TRL	280A TGK® Gun, 15' Cable, .030"-.035" L-Series liner, Lincoln® Plug		

THERMACUT®, FHT-EX® AND EX-TRAFIRE® ARE REGISTERED TRADEMARKS OF THERMACUT, K. S. AND MAY BE REGISTERED IN CZECH REPUBLIC AND/OR OTHER COUNTRIES. ALL OTHER TRADEMARKS ARE PROPERTIES OF THEIR RESPECTIVE OWNERS. THERMACUT IS NO WAY AFFILIATED WITH TREGASKISS®. MOST THERMACUT PARTS ARE MADE FOR OR BY AN IBG COMPANY. PARTS INDICATED WITH A OEM ARE ORIGINAL PARTS MANUFACTURED BY THE ABOVE NAMED MANUFACTURER AND ARE BEING RESOLD BY THERMACUT. THERMACUT RESERVES THE RIGHT TO SUBSTITUTE OEM PARTS IN PLACE OF THERMACUT PARTS. VALID FROM SEPTEMBER 2024 • PREVIOUS VERSION IS NO LONGER VALID. • © COPYRIGHT 2024 BY THERMACUT® CZECH REPUBLIC. ALL RIGHTS RESERVED.

**THERMACUT® REPLACEMENT PARTS SUITABLE FOR
TREGASKISS® GUN
TOUGH GUN® 200, 300, 400, 500**

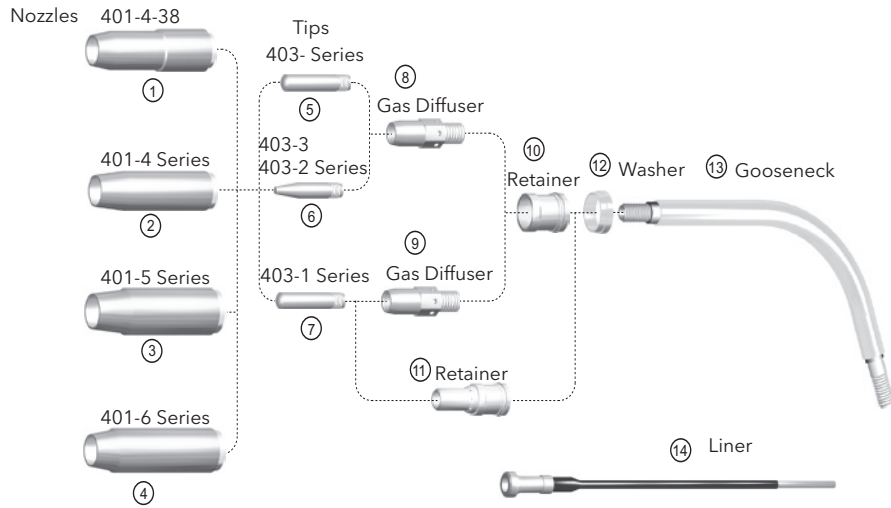

Item	Part No.	Description	Std. Pkg.	Item	Part No.	Description	Std. Pkg.
1.	401-4-38	Nozzle Insul. 3/8", Flush	5		402-7	Shock Washer	5
2.	401-4-50	Nozzle Insul. 1/2", 1/8" Recess	5	13.	305-60	Gooseneck 300A	1
	401-4-62	Nozzle Insul. 5/8", 1/8" Recess	5		405-60	Gooseneck 400A	1
	401-4-75	Nozzle Insul. 3/4", 1/8" Recess	5	14.	415-116-15	Liner 15', .045 -1/16	1
3.	401-5-62	Nozzle Insul. 5/8" HD	5		415-116-25	Liner 25', .045 -1/16	1
	401-5-75	Nozzle Insul. 3/4" HD	5		415-35-15	Liner 15', .035	1
4.	401-6-75	Nozzle HD Insul. 3/4", 1/8" Recess	5		415-35-25	Liner 25', .035	1
	401-6-62	Nozzle HD Insul. 5/8", 1/8" Recess	5		415-332-15	Liner 15', .078 -3/32	1
5.	403-45	Contact Tip .045	25		415-116-2	Liner 15', .045 -1/16	1
	403-116	Contact Tip 1/16	25		415-564-25	Liner 25', 5/64"	1
	403-52	Contact Tip .052	25	NS	401-42-50	Nozzle Insul. 1/2", 1/8" Recess	5
	403-35	Contact Tip .035	25	NS	401-48-50	Nozzle Insul. 1/2", 1/8" Stickout	5
6.	403-3-35	Contact Tip HD Tapered .035	25	NS	401-48-62	Nozzle Insul. 5/8", HD Flush	5
	403-3-52	Contact Tip .052" HD	25	NS	401-7-62	Nozzle Insul. 5/8", HD 1/8" Recess	5
	403-3-116	Contact Tip 1/16" HD	25	NS	401-81-62	Nozzle Insul. 5/8", 1/8" Stickout	5
	403-3-45	Contact Tip HD Tapered .045	25	NS	403-27-1.0	Contact Tip .040, HD	25
	403-2-35	Contact Tip Tapered .050	25	NS	403-27-35	Contact Tip .035, HD	25
7.	403-1-35	Contact Tip .035 HD	25	NS	403-27-45	Contact Tip .045, HD	25
	403-1-116	Contact Tip 1/16" HD	25	NS	403-20-30	Contact Tip .030, HD	25
	403-1-40	Contact Tip .040" HD	25	NS	403-20-35	Contact Tip .035, HD	25
	403-1-45	Contact Tip .045" HD	25	NS	403-20-1.0	Contact Tip .040, HD	25
	403-1-52	Contact Tip .052" HD	25	NS	403-20-45	Contact Tip .045, HD	25
	403-1-332	Contact Tip 3/32" HD	25	NS	403-20-364	Contact Tip 3/64, HD	25
	403-1-40	Contact Tip .040" HD	25	NS	403-20-52	Contact Tip .052, HD	25
8.	404	Gas Diffuser	5	NS	403-20-116	Contact Tip 1/16, HD	25
	404-10	Gas Diffuser	5	NS	403-21-30	Contact Tip .030, Tapered HD	25
9.	404-1	Gas Diffuser HD	5	NS	403-21-35	Contact Tip .035, Tapered HD	25
10.	402-3	Nozzle Retaining Ring	5	NS	403-21-45	Contact Tip .045, Tapered HD	25
11.	402-4	Retaining Ring	5	NS	404-20	Gas Diffuser for Robotic Applications	5
	404-3	Retainer	5	NS	404-30	Gas Diffuser for Semi-automatic Applications	5
	404-13	Retaining Head with Setscrew	5	NS	402-11	Shock Washer HD	5
12.	402-5	Shock Washer HD	5				

THERMACUT®, FHT-EX® AND EX-TRAFIRE® ARE REGISTERED TRADEMARKS OF THERMACUT, K. S. AND MAY BE REGISTERED IN CZECH REPUBLIC AND/OR OTHER COUNTRIES. ALL OTHER TRADEMARKS ARE PROPERTIES OF THEIR RESPECTIVE OWNERS. THERMACUT IS NO WAY AFFILIATED WITH TREGASKISS®. MOST THERMACUT PARTS ARE MADE FOR OR BY AN IBG COMPANY. PARTS INDICATED WITH A OEM ARE ORIGINAL PARTS MANUFACTURED BY THE ABOVE NAMED MANUFACTURER AND ARE BEING RESOLD BY THERMACUT. THERMACUT RESERVES THE RIGHT TO SUBSTITUTE OEM PARTS IN PLACE OF THERMACUT PARTS. VALID FROM SEPTEMBER 2024 • PREVIOUS VERSION IS NO LONGER VALID. • © COPYRIGHT 2024 BY THERMACUT® CZECH REPUBLIC. ALL RIGHTS RESERVED.

THERMACUT® REPLACEMENT PARTS SUITABLE FOR TREGASKISS® GUN 400A GUN

Item	Part No.	Description	Std. Pkg.	Item	Part No.	Description	Std. Pkg.
1.	404-3	Gas Diffuser/Retainer	5		401-6-75	Nozzle HD Insul. 3/4", 1/8" Recess	5
	404-13	Gas Diffuser/Retainer with Setscrew	5		401-6-62	Nozzle HD Insul. 5/8", 1/8" Recess	5
2.	403-35	Contact Tip .035	25	4.	402-5	Shock Washer HD	5
	403-45	Contact Tip .045	25	5.	40HR	Locking Ring (400A)	1
	403-52	Contact Tip .052	25	6.	40HD	Handle Kit /w Screws (400A)	1
	403-116	Contact Tip 1/16	25	7.	25GH	Hanger Hook	1
	403-1-35	Contact Tip .035 HD	25	8.	25TB	Trigger Blade	1
	403-1-40	Contact Tip .040" HD	25	9.	25TR	Trigger Switch	1
	403-1-45	Contact Tip .045" HD	25	10.	40BK	Tube Block	1
	403-1-52	Contact Tip .052" HD	25	11.	40CTT	Swan Neck (400A)	1
	403-1-116	Contact Tip 1/16" HD	25	12.	25MA	Trigger Connector, Miller® Style	1
	403-1-332	Contact Tip 3/32" HD	25	13.	25LA	Trigger Connector, Lincoln® Style	1
	403-2-35	Contact Tip Tapered .035	25	14.	25CH	Plug Housing	1
	403-2-45	Contact Tip Tapered .045	25	15.	25RR	Retaining Ring	1
	403-3-35	Contact Tip HD Tapered .035	25	16.	40CBR	Connector Body	1
	403-3-45	Contact Tip HD Tapered .045	25	17.	40CW	Stop Washer	1
	403-3-52	Contact Tip HD Tapered .052	25	18.	25CR	Connector Ring	1
	403-3-116	Contact Tip HD Tapered 1/16	25	19.	40TC-TR	Connector, Tweco® Style, for L-series Liners	1
3.	401-4-38	Nozzle Insul. 3/8", Flush	5	20.	40MCB	Connector, Miller® Style, for L-series Liners	1
	401-4-50	Nozzle Insul. 1/2", 1/8" Recess	5	21.	L4A-15	Liner, .045 x 1/16, 15'	1
	401-4-62	Nozzle Insul. 5/8", 1/8" Recess	5		L4A-25	Liner, .045 x 1/16, 25'	1
	401-4-75	Nozzle Insul. 3/4", 1/8" Recess	5	22.	40PC	Power Cable, 15'	1
	401-5-62	Nozzle Insul. 5/8" HD	5		40PC12	Power Cable, 12'	1
	401-5-75	Nozzle Insul. 3/4" HD	5				

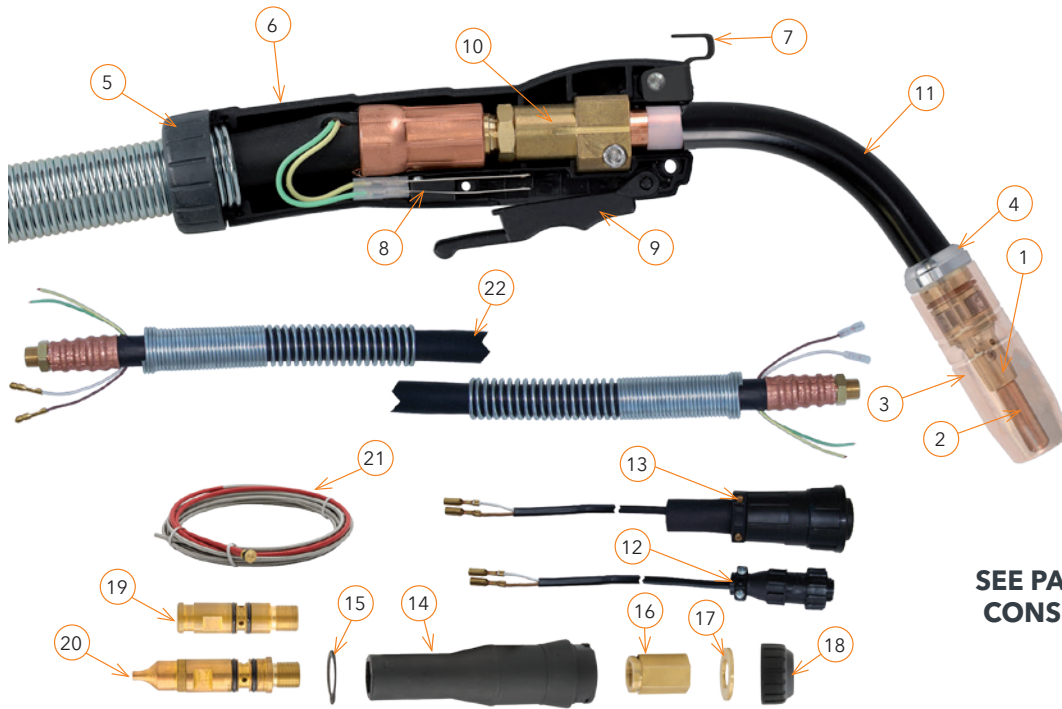

**SEE PAGE 155 FOR MORE
CONSUMABLE OPTIONS**

Model	Description	Model	Description
400TR153545TRT	400A TGK® Gun, 15' Cable, .035"-.045" L-Series liner, Tweco® Plug	400TR15116TRL	400A TGK® Gun, 15' Cable, 1/16" L-Series liner, Lincoln® Plug
400TR15116TRT	400A TGK® Gun, 15' Cable, 1/16" L-Series liner, Tweco® Plug	400TR153545TRL2	400A TGK® Gun, 15' Cable, .035"-.045" L-Series liner, Tweco® Lincoln® Plug
400TR153545TRM	400A TGK® Gun, 15' Cable, .035"-.045" L-Series liner, Miller® Plug	400TR15116TRL2	400A TGK® Gun, 15' Cable, 1/16" L-Series liner, Tweco®-Lincoln® Plug
400TR15116TRM	400A TGK® Gun, 15' Cable, 1/16" L-Series liner, Miller® Plug	400TR153545E	400A TGK® Gun, 15' Cable, .035"-.045" Tweco® liner, Euro Plug
400TR153545TRL	400A TGK® Gun, 15' Cable, .035"-.045" L-Series liner, Lincoln® Plug		

THERMACUT®, FHT-EX® AND EX-TRAFIRE® ARE REGISTERED TRADEMARKS OF THERMACUT, K. S. AND MAY BE REGISTERED IN CZECH REPUBLIC AND/OR OTHER COUNTRIES. ALL OTHER TRADEMARKS ARE PROPERTIES OF THEIR RESPECTIVE OWNERS. THERMACUT IS NO WAY AFFILIATED WITH TREGASKISS®. MOST THERMACUT PARTS ARE MADE FOR OR BY AN IBG COMPANY. PARTS INDICATED WITH A OEM ARE ORIGINAL PARTS MANUFACTURED BY THE ABOVE NAMED MANUFACTURER AND ARE BEING RESOLD BY THERMACUT. THERMACUT RESERVES THE RIGHT TO SUBSTITUTE OEM PARTS IN PLACE OF THERMACUT PARTS.
VALID FROM SEPTEMBER 2024 • PREVIOUS VERSION IS NO LONGER VALID. • © COPYRIGHT 2024 BY THERMACUT® CZECH REPUBLIC. ALL RIGHTS RESERVED.

**THERMACUT® REPLACEMENT PARTS SUITABLE FOR
TREGASKISS® GUN
TOUGH GUN® 200, 300, 400, 500**

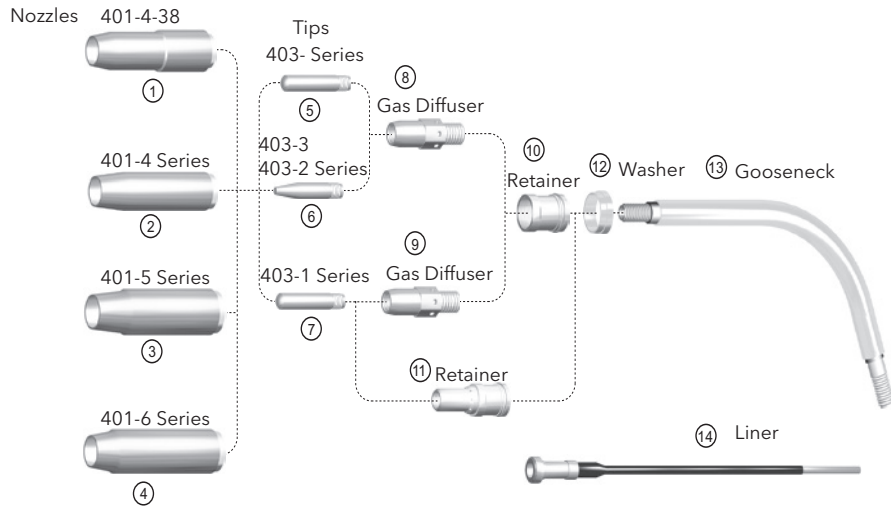

Item	Part No.	Description	Std. Pkg.	Item	Part No.	Description	Std. Pkg.
1.	401-4-38	Nozzle Insul. 3/8", Flush	5		402-7	Shock Washer	5
2.	401-4-50	Nozzle Insul. 1/2", 1/8" Recess	5	13.	305-60	Gooseneck 300A	1
	401-4-62	Nozzle Insul. 5/8", 1/8" Recess	5		405-60	Gooseneck 400A	1
	401-4-75	Nozzle Insul. 3/4", 1/8" Recess	5	14.	415-116-15	Liner 15', .045 -1/16	1
3.	401-5-62	Nozzle Insul. 5/8" HD	5		415-116-25	Liner 25', .045 -1/16	1
	401-5-75	Nozzle Insul. 3/4" HD	5		415-35-15	Liner 15', .035	1
4.	401-6-75	Nozzle HD Insul. 3/4", 1/8" Recess	5		415-35-25	Liner 25', .035	1
	401-6-62	Nozzle HD Insul. 5/8", 1/8" Recess	5		415-332-15	Liner 15', .078 -3/32	1
5.	403-45	Contact Tip .045	25		415-116-2	Liner 15', .045 -1/16	1
	403-116	Contact Tip 1/16	25		415-564-25	Liner 25', 5/64"	1
	403-52	Contact Tip .052	25	NS	401-42-50	Nozzle Insul. 1/2", 1/8" Recess	5
	403-35	Contact Tip .035	25	NS	401-48-50	Nozzle Insul. 1/2", 1/8" Stickout	5
6.	403-3-35	Contact Tip HD Tapered .035	25	NS	401-48-62	Nozzle Insul. 5/8", HD Flush	5
	403-3-52	Contact Tip .052" HD	25	NS	401-7-62	Nozzle Insul. 5/8", HD 1/8" Recess	5
	403-3-116	Contact Tip 1/16" HD	25	NS	401-81-62	Nozzle Insul. 5/8", 1/8" Stickout	5
	403-3-45	Contact Tip HD Tapered .045	25	NS	403-27-1.0	Contact Tip .040, HD	25
	403-2-35	Contact Tip Tapered .050	25	NS	403-27-35	Contact Tip .035, HD	25
7.	403-1-35	Contact Tip .035 HD	25	NS	403-27-45	Contact Tip .045, HD	25
	403-1-116	Contact Tip 1/16" HD	25	NS	403-20-30	Contact Tip .030, HD	25
	403-1-40	Contact Tip .040" HD	25	NS	403-20-35	Contact Tip .035, HD	25
	403-1-45	Contact Tip .045" HD	25	NS	403-20-1.0	Contact Tip .040, HD	25
	403-1-52	Contact Tip .052" HD	25	NS	403-20-45	Contact Tip .045, HD	25
	403-1-332	Contact Tip 3/32" HD	25	NS	403-20-364	Contact Tip 3/64, HD	25
	403-1-40	Contact Tip .040" HD	25	NS	403-20-52	Contact Tip .052, HD	25
8.	404	Gas Diffuser	5	NS	403-20-116	Contact Tip 1/16, HD	25
	404-10	Gas Diffuser	5	NS	403-21-30	Contact Tip .030, Tapered HD	25
9.	404-1	Gas Diffuser HD	5	NS	403-21-35	Contact Tip .035, Tapered HD	25
10.	402-3	Nozzle Retaining Ring	5	NS	403-21-45	Contact Tip .045, Tapered HD	25
11.	402-4	Retaining Ring	5	NS	404-20	Gas Diffuser for Robotic Applications	5
	404-3	Retainer	5	NS	404-30	Gas Diffuser for Semi-automatic Applications	5
	404-13	Retaining Head with Setscrew	5	NS	402-11	Shock Washer HD	5
12.	402-5	Shock Washer HD	5				

THERMACUT®, FHT-EX® AND EX-TRAFIRE® ARE REGISTERED TRADEMARKS OF THERMACUT, K. S. AND MAY BE REGISTERED IN CZECH REPUBLIC AND/OR OTHER COUNTRIES. ALL OTHER TRADEMARKS ARE PROPERTIES OF THEIR RESPECTIVE OWNERS. THERMACUT IS NO WAY AFFILIATED WITH TREGASKISS®. MOST THERMACUT PARTS ARE MADE FOR OR BY AN IBG COMPANY. PARTS INDICATED WITH A OEM ARE ORIGINAL PARTS MANUFACTURED BY THE ABOVE NAMED MANUFACTURER AND ARE BEING RESOLD BY THERMACUT. THERMACUT RESERVES THE RIGHT TO SUBSTITUTE OEM PARTS IN PLACE OF THERMACUT PARTS. VALID FROM SEPTEMBER 2024 • PREVIOUS VERSION IS NO LONGER VALID. • © COPYRIGHT 2024 BY THERMACUT® CZECH REPUBLIC. ALL RIGHTS RESERVED.

THERMACUT® REPLACEMENT PARTS SUITABLE FOR TWECO® GUN 160A GUN

Item	Part No.	Description	Std. Pkg.	Item	Part No.	Description	Std. Pkg.
1.	35-50	Gas Diffuser, Mini	5		21-62	Nozzle 5/8" Insulated	5
	51	Gas Diffuser #1 .035 -.045	5		21-62F	Nozzle Flush 5/8", Insulated	5
	51-23	Gas Diffuser, #1 .023 MINI	5		21T-37	Nozzle Taper, 1/8" Recess	5
2.	11-23	Contact Tip .023	25	4.	13SR	Strain Relief (160A)	1
	11-30	Contact Tip .030	25	5.	13HR	Locking Ring (160A)	1
	11-35	Contact Tip .035	25	6.	13HD	Handle Kit /w Screws (160A)	1
	11-40	Contact Tip .040	25	7.	25GH	Hanger Hook	1
	11-45	Contact Tip .045	25	8.	25TB	Trigger Blade	1
	11T-23	Contact Tip .023, Tapered	25	9.	25TR	Trigger Switch	1
	11T-30	Contact Tip .030, Tapered	25	10.	13BK	Tube Block (160A)	1
	11T-35	Contact Tip .035, Tapered	25	11.	13CT	Swan Neck (160A)	1
	11T-45	Contact Tip .045, Tapered	25	12.	13TC	Connector, Tweco® Style, for Tweco Liners	1
	11H45	Contact Tip HD .045	25	13.	13MC	Connector, Miller® Style, for Tweco Liners	1
	11H35	Contact Tip HD .035	25	14.	13TA	Trigger Connector, Tweco® Style	1
	11H40	Contact Tip HD .040	25	15.	23-40-15	Liner 15' .023	1
3.	21-37	Nozzle 3/8" Insulated	5		35-40-15	Liner 15' .030 -.035	1
	21-50	Nozzle 5/8" Insulated	5		45-40-15	Liner 15', .045	1
	21-50F	Nozzle Flush 1/2", Insulated	5	16.	13PC	Power Cable, 10'	1

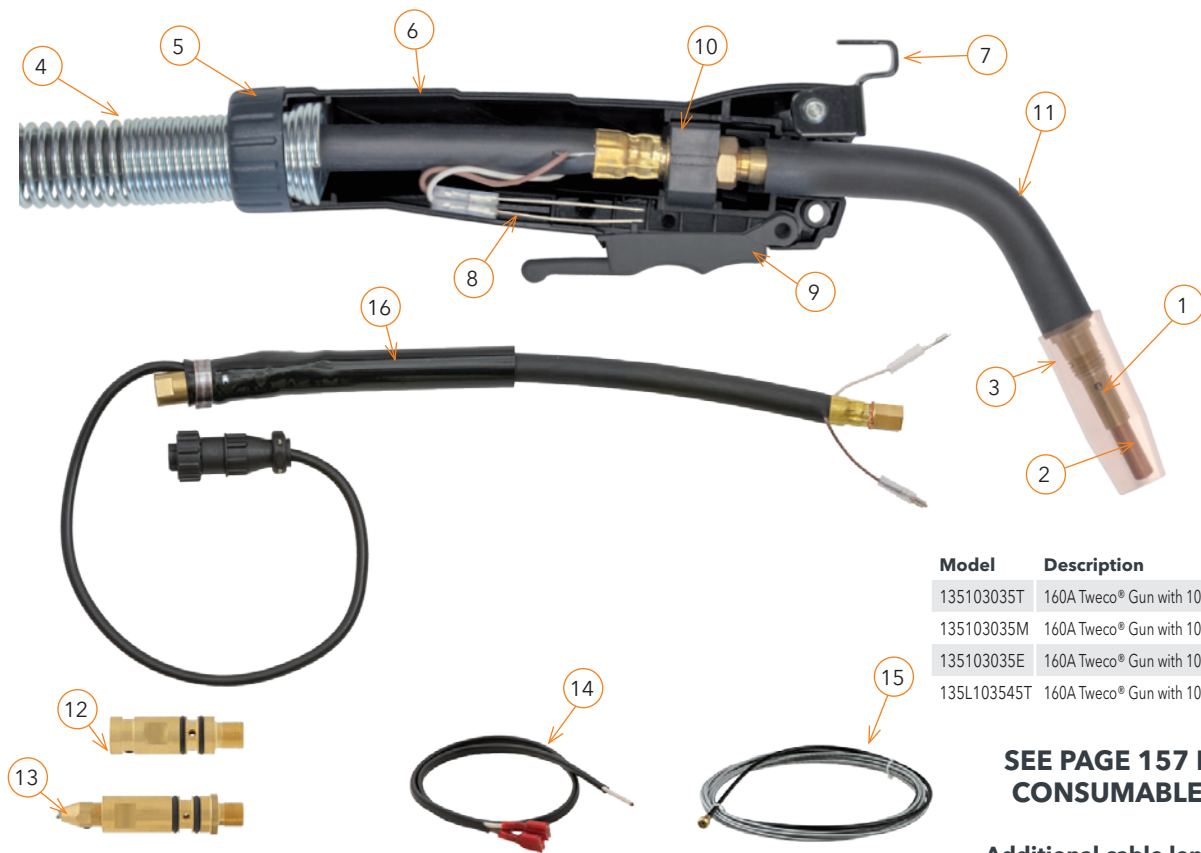

Model	Description
135103035T	160A Tweco® Gun with 10' Cable, .030"-.035", Tweco® Plug
135103035M	160A Tweco® Gun with 10' Cable, .030"-.035", Miller® Plug
135103035E	160A Tweco® Gun with 10' Cable, .030"-.035", Euro Plug
135L103545T	160A Tweco® Gun with 10' Cable, .035"-.045", Tweco® Plug

**SEE PAGE 157 FOR MORE
CONSUMABLE OPTIONS**

**Additional cable lengths available.
Call for details.**

THERMACUT®, FHT-EX® AND EX-TRAFIRE® ARE REGISTERED TRADEMARKS OF THERMACUT, K. S. AND MAY BE REGISTERED IN CZECH REPUBLIC AND/OR OTHER COUNTRIES. ALL OTHER TRADEMARKS ARE PROPERTIES OF THEIR RESPECTIVE OWNERS. THERMACUT IS NO WAY AFFILIATED WITH TWECO®. MOST THERMACUT PARTS ARE MADE FOR OR BY AN IBG COMPANY. PARTS INDICATED WITH A OEM ARE ORIGINAL PARTS MANUFACTURED BY THE ABOVE NAMED MANUFACTURER AND ARE BEING RESOLD BY THERMACUT. THERMACUT RESERVES THE RIGHT TO SUBSTITUTE OEM PARTS IN PLACE OF THERMACUT PARTS. VALID FROM SEPTEMBER 2024 • PREVIOUS VERSION IS NO LONGER VALID. • © COPYRIGHT 2024 BY THERMACUT® CZECH REPUBLIC. ALL RIGHTS RESERVED.

THERMACUT® REPLACEMENT PARTS SUITABLE FOR TWECO® GUN 160A GUN

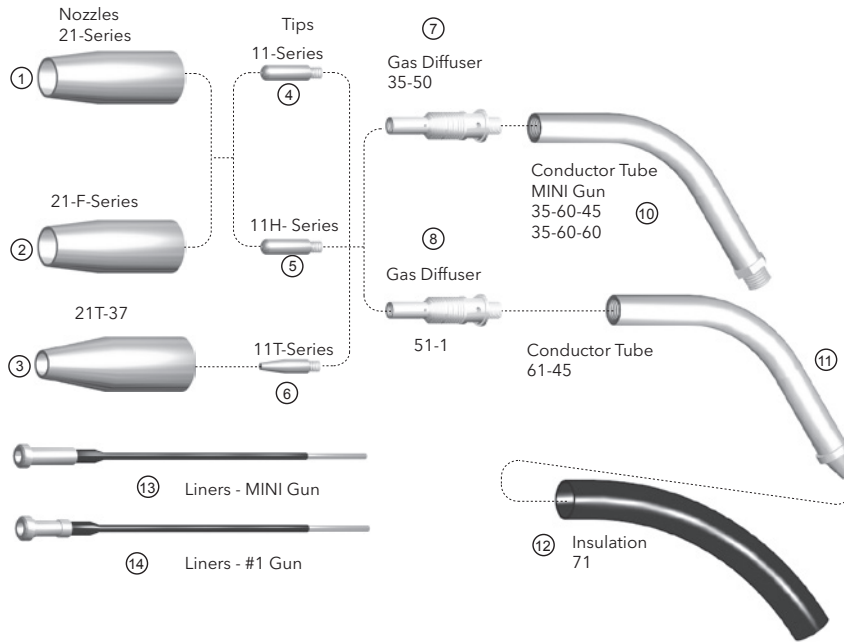

Item	Part No.	Description	Std. Pkg.	Item	Part No.	Description	Std. Pkg.
1.	21-37	Nozzle 3/8" Insulated	5	7.	35-50	Gas Diffuser, Mini	25
	21-50	Nozzle 1/2" Insulated	5	8.	51	Gas Diffuser #1 .035 -.045	5
	21-62	Nozzle 5/8" Insulated	5		51-23	Gas Diffuser, #1 .023 MINI	5
2.	21-37F	Nozzle Flush 3/8", Insulated	5	10.	35-60-60	Conductor Tube 60/60°	5
	21-50F	Nozzle Flush 1/2", Insulated	5	11.	61-45	Conductor Tube 45°	5
	21-62F	Nozzle Flush 5/8", Insulated	5	12.	71	Insulation #1 Gun	1
3.	21T37	Nozzle Taper, 1/8" Recess	5	13.	42-23-15	Liner 15', .023	1
4.	11-45	Contact Tip .045	25		42-3035-15	Liner 15', .030 -.035	1
	11-23	Contact Tip .023	25		42-3035-25	Liner 25', .030 -.035	1
	11-30	Contact Tip .030	25		42-4045-15	Liner 15', .040 -.045	1
	11-35	Contact Tip .035	25		42-4045-25	Liner 25', .040 -.045	1
	11-40	Contact Tip .040	25		42N-3545-15	Liner Nylon 15' .035 -.045	1
5.	11H45	Contact Tip HD .045	25	14.	23-40-15	Liner 15' .023	1
	11H35	Contact Tip HD .035	25		35-40-15	Liner 15' .030 -.035	1
	11H30	Contact Tip HD .030	25		35TF-40-10	Liner 15' PTFE 10' .035	1
6.	11T45	Contact Tip .045, Tapered	25		45-40-15	Liner 15', .045	1
	11T23	Contact Tip .023, Tapered	25		122FM	Binder Screw & Post	5
	11T30	Contact Tip .030, Tapered	25				
	11T35	Contact Tip .035, Tapered	25				
	11T40	Contact Tip .040, Tapered	25				

THERMACUT®, FHT-EX® AND EX-TRAFIRE® ARE REGISTERED TRADEMARKS OF THERMACUT, K. S. AND MAY BE REGISTERED IN CZECH REPUBLIC AND/OR OTHER COUNTRIES. ALL OTHER TRADEMARKS ARE PROPERTIES OF THEIR RESPECTIVE OWNERS. THERMACUT IS NO WAY AFFILIATED WITH TWECO®. MOST THERMACUT PARTS ARE MADE FOR OR BY AN IBG COMPANY. PARTS INDICATED WITH A OEM ARE ORIGINAL PARTS MANUFACTURED BY THE ABOVE NAMED MANUFACTURER AND ARE BEING RESOLD BY THERMACUT. THERMACUT RESERVES THE RIGHT TO SUBSTITUTE OEM PARTS IN PLACE OF THERMACUT PARTS. VALID FROM SEPTEMBER 2024 • PREVIOUS VERSION IS NO LONGER VALID. • © COPYRIGHT 2024 BY THERMACUT® CZECH REPUBLIC. ALL RIGHTS RESERVED.

THERMACUT® REPLACEMENT PARTS SUITABLE FOR TWECO® GUN 280A GUN

Item	Part No.	Description	Std. Pkg.	Item	Part No.	Description	Std. Pkg.
1.	52	Gas Diffuser, .030-.045	5		23T-37	Nozzle 3/8", #2,3,4	5
	52-23	Gas Diffuser, .023	5		23-37F	Nozzle Insul. 3/8", Flush	5
	52FN	Gas Diffuser, Fixed Nozzle	5		23-50F	Nozzle Insul. 1/2", Flush	5
2.	14-23	Contact Tip .023	25		23-62F	Nozzle Insul. 5/8", Flush	5
	14-30	Contact Tip .030	25	5.	25SR	Strain Relief (280A)	1
	14-35	Contact Tip .035	25	6.	25HR	Locking Ring (280A)	1
	14-40	Contact Tip .040	25	7.	25HD	Handle Kit /w Screws (250A)	1
	14-45	Contact Tip .045	25	8.	25GH	Hanger Hook	1
	14-52	Contact Tip .052	25	9.	25TB	Trigger Blade	1
	14T-23	Contact Tip Tapered .023	25	10.	25TR	Trigger Switch	1
	14T-30	Contact Tip Tapered .030	25	11.	25BK	Tube Block	1
	14T-35	Contact Tip Tapered .035	25	12.	25CT	Swan Neck (280A)	1
	14T-40	Contact Tip Tapered .040	25	13.	25MA	Trigger Connector, Miller® Style	1
	14T-45	Contact Tip Tapered .045	25	14.	25LA	Trigger Connector, Lincoln® Style	1
	14H-35	Contact Tip .035 HD	25	15.	25CH	Plug Housing	1
	14H-40	Contact Tip .040 HD	25	16.	25RR	Retaining Ring	1
	14H-45	Contact Tip .045 HD	25	17.	25CBR	Connector Body	1
3.	32	Insulator #2	5	18.	25CW	Stop Washer	1
	34A	Insulator #2,3,4	5	19.	25CR	Connector Ring	1
4.	22-50	Nozzle 1/2", #2	5	20.	25TC	Connector, Tweco® Style, for Tweco Liners	1
	22-50SS	Nozzle Short 1/2", #2	5	21.	25MC	Connector, Miller® Style, for Tweco Liners	1
	22-62	Nozzle 5/8", #2	5	22.	25LC	Connector, Lincoln® Style, for Tweco Liners	1
	22-62SS	Nozzle Short 5/8", #2	5	23.	42-23-15	Liner 15', .023	1
	22-37SS	Nozzle Short 3/8"	5		42-3035-15	Liner 15', .030-.035	1
	22T-37SS	Nozzle Tapered, 3/8", #2	5		42-3035-25	Liner 25', .030-.035	1
	23-37	Nozzle Insul. 3/8", #2,3,4	5		42-4045-15	Liner 15', .040-.045	1
	23-50	Nozzle Insul. 1/2", #2,3,4	5		42-4045-25	Liner 25', .040-.045	1
	23-62	Nozzle Insul. 5/8", #2,3,4	5		42N-3545-15	Liner Nylon 15', .035-.045	1
	23H-62	Nozzle, 5/8"	5	24.	25PC	Power Cable, 15'	1
	23-75	Nozzle Insul. 3/4", #2,3,4	5		25PC12	Power Cable, 12'	1



Model	Description
250153035T	280A Tweco® Gun with 15' Cable, .030" - .035", Tweco® Plug
250153545T	280A Tweco® Gun with 15' Cable, .035" - .045", Tweco® Plug
250123035M	280A Tweco® Gun with 12' Cable, .030" - .035", Miller® Plug
250153035M	280A Tweco® Gun with 15' Cable, .030" - .035", Miller® Plug
250153545M	280A Tweco® Gun with 15' Cable, .035" - .045", Miller® Plug

Model	Description
250153545L	280A Tweco® Gun with 15' Cable, .035" - .045", Lincoln® Plug
250153035L2	280A Tweco® Gun with 15' Cable, .030" - .035", Tweco®-Lincoln® Plug
250153545L2	280A Tweco® Gun with 15' Cable, .035" - .045", Tweco®-Lincoln® Plug
250153035E	280A Tweco® Gun with 15' Cable, .030" - .035", Euro Plug

**Additional cable lengths available.
Call for details.**

**SEE PAGE 159 FOR MORE
CONSUMABLE OPTIONS**

THERMACUT®, FHT-EX® AND EX-TRAFIRE® ARE REGISTERED TRADEMARKS OF THERMACUT, K. S. AND MAY BE REGISTERED IN CZECH REPUBLIC AND/OR OTHER COUNTRIES. ALL OTHER TRADEMARKS ARE PROPERTIES OF THEIR RESPECTIVE OWNERS. THERMACUT IS NO WAY AFFILIATED WITH TWECO®. MOST THERMACUT PARTS ARE MADE FOR OR BY AN IBG COMPANY. PARTS INDICATED WITH A OEM ARE ORIGINAL PARTS MANUFACTURED BY THE ABOVE NAMED MANUFACTURER AND ARE BEING RESOLD BY THERMACUT. THERMACUT RESERVES THE RIGHT TO SUBSTITUTE OEM PARTS IN PLACE OF THERMACUT PARTS.
VALID FROM SEPTEMBER 2024 • PREVIOUS VERSION IS NO LONGER VALID. • © COPYRIGHT 2024 BY THERMACUT® CZECH REPUBLIC. ALL RIGHTS RESERVED.

THERMACUT® REPLACEMENT PARTS SUITABLE FOR TWECO® GUN 280A GUN

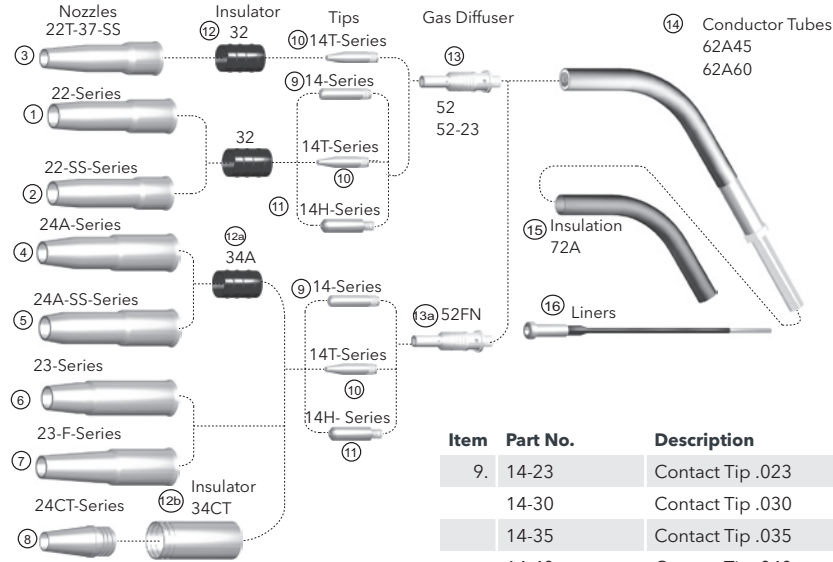

Item	Part No.	Description	Std. Pkg.	
1.	22-50	Nozzle 1/2", #2	5	
	22-62	Nozzle 5/8", #2	5	
	2.	22-50SS	Nozzle Short 1/2", #2	5
		22-62SS	Nozzle Short 5/8", #2	5
		22-37SS	Nozzle Short 3/8"	5
		22T37SS	Nozzle Tapered, 3/8", #2	5
	3.	24A50	Nozzle 1/2", #2,3,4	5
		24A62	Nozzle 5/8", #2,3,4	5
		24A75	Nozzle 3/4", #2,3,4	5
		24A37SS	Nozzle Short Stop 3/8", #2,3,4	5
4.	24A50SS	Nozzle Short Stop 1/2", #2,3,4	5	
	24A62SS	Nozzle Short Stop 5/8", #2,3,4	5	
	24A75SS	Nozzle Short Stop 3/4", #2,3,4	5	
	24AT37SS	Nozzle 3/8", #2,3,4	5	
	5.	23-37	Nozzle Insul. 3/8", #2,3,4	5
23-50		Nozzle Insul. 1/2", #2,3,4	5	
23-62		Nozzle Insul. 5/8", #2,3,4	5	
23H62		Nozzle, 5/8"	5	
23-75		Nozzle Insul. 3/4", #2,3,4	5	
23T37		Nozzle 3/8", #2,3,4	5	
23-37F		Nozzle Insul. 3/8", Flush	5	
6.	23-50F	Nozzle Insul. 1/2", Flush	5	
	23-62F	Nozzle Insul. 5/8", Flush	5	
	7.	24CT37S	Nozzle 3/8", #2,3,4	5
24CT50S		Nozzle 1/2", Coarse, #2,3,4	5	
24CT62R		Nozzle 5/8", Coarse, #2,3,4	5	
24CT62S		Nozzle 5/8", Coarse, #2,3,4	5	
24CT75S		Nozzle 3/4", Coarse, #2,3,4	5	
9.	14-23	Contact Tip .023	25	
	14-30	Contact Tip .030	25	
	14-35	Contact Tip .035	25	
	14-40	Contact Tip .040	25	
	14-45	Contact Tip .045	25	
	14-52	Contact Tip .052	25	
	14A364	Contact Tip 3/64"	25	
	14T23	Contact Tip Tapered .023	25	
	14T30	Contact Tip Tapered .030	25	
	14T35	Contact Tip Tapered .035	25	
10.	14H364	Contact Tip 3/64"	25	
	14H35	Contact Tip .035 HD	25	
	14H40	Contact Tip .040 HD	25	
	14H45	Contact Tip .045 HD	25	
	14H52	Contact Tip .052 HD	25	
11.	32	Insulator #2	5	
	T-4032	Insulator, 32 Series	5	
12.	34A	Insulator #2,3,4	5	
	T-4034	Insulator, 34A Series	5	
12a.	34FN	Insulator, Fine Thread	5	
	34CT	Insulator, Coarse Thread	5	
12b.	52	Gas Diffuser, .030-.045	5	
	52-23	Gas Diffuser, .023	5	
13.	52FN	Gas Diffuser, Fixed Nozzle	5	
	13a.	62A45	Conductor Tube 45°	1
62A60		Conductor Tube 60°	1	
14.	72A	Insulation #2 Gun	5	
	15.	42-23-15	Liner 15', .023	1
42-3035-15		Liner 15', .030-.035	1	
42-3035-25		Liner 25', .030-.035	1	
42-4045-15		Liner 15', .040-.045	1	
42-4045-25		Liner 25', .040-.045	1	
42N-3545-15	Liner Nylon 15', .035-.045	1		

THERMACUT®, FHT-EX® AND EX-TRAFIRE® ARE REGISTERED TRADEMARKS OF THERMACUT, K. S. AND MAY BE REGISTERED IN CZECH REPUBLIC AND/OR OTHER COUNTRIES. ALL OTHER TRADEMARKS ARE PROPERTIES OF THEIR RESPECTIVE OWNERS. THERMACUT IS NO WAY AFFILIATED WITH TWECO®. MOST THERMACUT PARTS ARE MADE FOR OR BY AN IBG COMPANY. PARTS INDICATED WITH A OEM ARE ORIGINAL PARTS MANUFACTURED BY THE ABOVE NAMED MANUFACTURER AND ARE BEING RESOLD BY THERMACUT. THERMACUT RESERVES THE RIGHT TO SUBSTITUTE OEM PARTS IN PLACE OF THERMACUT PARTS. VALID FROM SEPTEMBER 2024 • PREVIOUS VERSION IS NO LONGER VALID. • © COPYRIGHT 2024 BY THERMACUT® CZECH REPUBLIC. ALL RIGHTS RESERVED.

THERMACUT® REPLACEMENT PARTS SUITABLE FOR TWECO® GUN 400A GUN

Item	Part No.	Description	Std. Pkg.	Item	Part No.	Description	Std. Pkg.
1.	54A	Gas Diffuser	5		23-62F	Nozzle Insul. 5/8, Flush	5
2.	14-35	Contact Tip .035	25		23T-37-F	Nozzle Insul. Taper 3/8 Flush	5
	14-40	Contact Tip .040	25		24CT-37S	Nozzle 3/8	5
	14-45	Contact Tip .045	25		24CT-50S	Nozzle 1/2, Coarse Thread	5
	14-52	Contact Tip .052	25		24CT-62R	Nozzle 5/8	5
	14-116	Contact Tip 1/16	25		24CT-62S	Nozzle 5/8, Coarse Thread	5
	14-564	Contact Tip 5/64	25		24CT-75S	Nozzle 3/4, Coarse Thread	5
	14T-35	Contact Tip Tapered .035	25	4.	40HR	Locking Ring (400A)	1
	14T-40	Contact Tip Tapered .040	25	5.	40HD	Handle Kit /w Screws (400A)	1
	14T-45	Contact Tip Tapered .045	25	6.	25GH	Hanger Hook	1
	14T-52	Contact Tip Tapered .052	25	7.	25TB	Trigger Blade	1
	14T-116	Contact Tip Tapered 1/16	25	8.	25TR	Trigger Switch	1
	14H-35	Contact Tip .035 HD	25	9.	40BK	Tube Block	1
	14H-40	Contact Tip .040 HD	25	10.	40CT	Swan Neck (400A)	1
	14H-45	Contact Tip .045 HD	25	11.	25MA	Trigger Connector, Miller® Style	1
	14H-52	Contact Tip .052 HD	25	12.	25LA	Trigger Connector, Lincoln® Style	1
	14H-116	Contact Tip 1/16 HD	25	13.	25CH	Plug Housing	1
	14H564	Contact Tip 5/64 HD	25	14.	25RR	Retaining Ring	1
3.	24A-50	Nozzle 1/2, #2,3,4	5	15.	40CBR	Connector Body	1
	24A-62	Nozzle 5/8, #2,3,4	5	16.	40CW	Stop Washer	1
	24A-75	Nozzle 3/4, #2,3,4	5	17.	25CR	Connector Ring	1
	24AH-62	Nozzle HD 5/8	5	18.	25TC	Connector, Tweco® Style, for Tweco Liners	1
	24AH-75	Nozzle HD 3/4	5	19.	25MC	Connector, Miller® Style, for Tweco Liners	1
	24A-50SS	Nozzle Short Stop 1/2	5	20.	25LC	Connector, Lincoln® Style, for Tweco Liners	1
	24A-62SS	Nozzle Short Stop 5/8	5	21.	44N-3545-15	Liner Nylon 25' .035-.045	1
	24A-75SS	Nozzle Short Stop 3/4	5		44-116-15	Liner 15' 1/16"	1
	24AT-37SS	Nozzle Short Stop 3/8, Taper	5		44-116-25	Liner 25' 1/16"	1
	23-37	Nozzle Insul. 3/8	5		44-3545-15	Liner 15' .035-.045	1
	23-50	Nozzle Insul. 1/2	5		44-3545-25	Liner 25' .035-.045	1
	23-62	Nozzle Insul. 5/8	5		44-564-15	Liner 15' 5/64"	1
	23-75	Nozzle Insul. 3/4	5		44-564-25	Liner 25' 5/64"	1
	23T37	Nozzle 3/8, Taper	5		44N-116-15	Liner Nylon 15' 1/16"	1
	23-37F	Nozzle Insul. 3/8, Flush	5	22.	40PC	Power Cable, 15'	1
	23-50F	Nozzle Insul. 1/2, Flush	5				

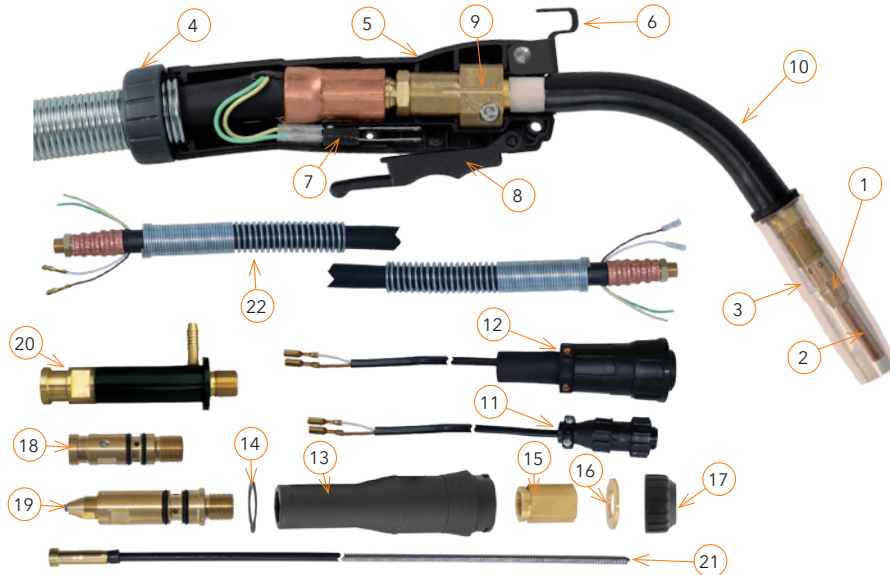

Model	Description
400153545T	400A Tweco® Gun with 15' Cable, .035" - .045", Tweco® Plug
40015116T	400A Tweco® Gun with 15' Cable, 1/16", Tweco® Plug
400153545M	400A Tweco® Gun with 15' Cable, .035" - .045", Miller® Plug
40015116M	400A Tweco® Gun with 15' Cable, 1/16", Miller® Plug

Model	Description
400153545L	400A Tweco® Gun with 15' Cable, .035" - .045", Lincoln® Plug
40015116L	400A Tweco® Gun with 15' Cable, 1/16", Lincoln® Plug
400153545L2	400A Tweco® Gun with 15' Cable .035" - .045", Tweco®-Lincoln® Plug
40015116L2	400A Tweco® Gun with 15' Cable 1/16", Tweco®-Lincoln® Plug

**Additional cable lengths available.
Call for details.**

**SEE PAGE 161 FOR MORE
CONSUMABLE OPTIONS**

THERMACUT®, FHT-EX® AND EX-TRAFIRE® ARE REGISTERED TRADEMARKS OF THERMACUT, K. S. AND MAY BE REGISTERED IN CZECH REPUBLIC AND/OR OTHER COUNTRIES. ALL OTHER TRADEMARKS ARE PROPERTIES OF THEIR RESPECTIVE OWNERS. THERMACUT IS NO WAY AFFILIATED WITH TWECO®. MOST THERMACUT PARTS ARE MADE FOR OR BY AN IBG COMPANY. PARTS INDICATED WITH A OEM ARE ORIGINAL PARTS MANUFACTURED BY THE ABOVE NAMED MANUFACTURER AND ARE BEING RESOLD BY THERMACUT. THERMACUT RESERVES THE RIGHT TO SUBSTITUTE OEM PARTS IN PLACE OF THERMACUT PARTS.
VALID FROM SEPTEMBER 2024 • PREVIOUS VERSION IS NO LONGER VALID. • © COPYRIGHT 2024 BY THERMACUT® CZECH REPUBLIC. ALL RIGHTS RESERVED.

THERMACUT® REPLACEMENT PARTS SUITABLE FOR TWECO® GUN 400A GUN

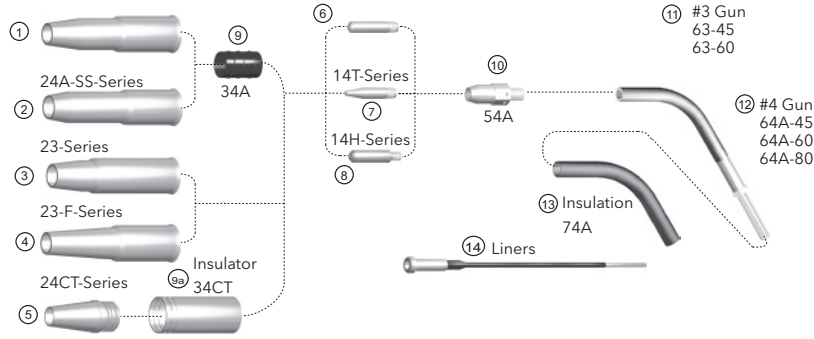

Item	Part No.	Description	Std. Pkg.	Item	Part No.	Description	Std. Pkg.
1.	24A50	Nozzle 1/2, #2,3,4	5	8.	14H116	Contact Tip 1/16" HD	25
	24A62	Nozzle 5/8, #2,3,4	5		14H35	Contact Tip .035 HD	25
	24A75	Nozzle 3/4, #2,3,4	5		14H40	Contact Tip .040 HD	25
	24AH62	Nozzle HD 5/8	5		14H45	Contact Tip .045 HD	25
	24AH75	Nozzle HD 3/4	5		14H52	Contact Tip .052 HD	25
2.	24A37SS	Nozzle Short Stop 3/8	5		14H564	Contact Tip 5/64" HD	5
	24A50SS	Nozzle Short Stop 1/2	5	9.	34A	Insulator #2,3,4 Gun	5
	24A62SS	Nozzle Short Stop 5/8	5	9a.	34CT	Insulator #2,3,4 Gun CT	5
	24A75SS	Nozzle Short Stop 3/4	5	10.	54A	Gas Diffuser	5
	24AT37SS	Nozzle Short Stop 3/8, Taper	5	11.	63-45	Conductor Tube 45°	1
3.	23-37	Nozzle Insul. 3/8	5		63-45J	Conductor Tube, Metal Jacketed	1
	23-50	Nozzle Insul. 1/2	5		63-60J	Conductor Tube, Metal Jacketed	1
	23-62	Nozzle Insul. 5/8	5	12.	64A60-12J	Conductor Tube, Metal Jacketed	1
	23-75	Nozzle Insul. 3/4	5		64A60-9J	Conductor Tube, Metal Jacketed	1
	23T37	Nozzle 3/8, Taper	5		64A60J	Conductor Tube, Metal Jacketed	1
4.	23-37F	Nozzle Insul. 3/8, Flush	5		64A45	Conductor Tube 45°	1
	23-50F	Nozzle Insul. 1/2, Flush	5		64A60	Conductor Tube 60°	1
	23-62F	Nozzle Insul. 5/8, Flush	5	13.	74A	Insulation	5
5.	24CT37S	Nozzle 3/8	5	14.	44N3545-15	Liner Nylon 25' .035-.045	1
	24CT50S	Nozzle 1/2, Coarse Thread	5		44-116-15	Liner 15' 1/16"	1
	24CT62R	Nozzle 5/8	5		44-116-25	Liner 25' 1/16"	1
	24CT62S	Nozzle 5/8, Coarse Thread	5		44-3545-15	Liner 15' .035-.045	1
	24CT75S	Nozzle 3/4, Coarse Thread	5		44-3545-25	Liner 25' .035-.045	1
6.	14-116	Contact Tip 1/16	25		44-564-15	Liner 15' 5/64"	1
	14-23	Contact Tip .023	25		44-564-25	Liner 25' 5/64"	1
	14-35	Contact Tip .035	25		44N-116-15	Liner Nylon 15' 1/16"	1
	14-45	Contact Tip .045	25	NS	94R	Switch Assembly	1
	14-52	Contact Tip .052	25	NS	144-12	Cable, 12'	1
	14-564	Contact Tip 5/64	25	NS	144-6	Hose Support Handle	5
	14A116	Contact Tip 1/16	25	NS	224	O-Ring	10
	14A364	Contact Tip 3/64	25	NS	34FN	Insulator, Fine Thread	5
7.	14T116	Contact Tip Tapered 1/16		NS	24FN50S	Nozzle 1/2", Fine Thread	5
	14T23	Contact Tip Tapered .023	25	NS	24FN62S	Nozzle 5/8", Fine Thread	5
	14T30	Contact Tip Tapered .030	25	NS	24FN75S	Nozzle 3/4", Fine Thread	5
	14T35	Contact Tip Tapered .035	25	NS	400-10	OEM #4 Hose Cable Assy, 10'	1
	14T40	Contact Tip Tapered .040	25	NS	400-15	OEM #4 Hose Cable Assy, 15'	1
	14T45	Contact Tip Tapered .045	25	NS	84A	Handle with Screws	1
	14T52	Contact Tip Tapered .052	25	NS	94C	Switch Blades	1
	14AH116	Contact Tip 1/16"	25				
	14AH364	Contact Tip 3/64"	25				

THERMACUT®, FHT-EX® AND EX-TRAFIRE® ARE REGISTERED TRADEMARKS OF THERMACUT, K. S. AND MAY BE REGISTERED IN CZECH REPUBLIC AND/OR OTHER COUNTRIES. ALL OTHER TRADEMARKS ARE PROPERTIES OF THEIR RESPECTIVE OWNERS. THERMACUT IS NO WAY AFFILIATED WITH TWECO®. MOST THERMACUT PARTS ARE MADE FOR OR BY AN IBG COMPANY. PARTS INDICATED WITH A OEM ARE ORIGINAL PARTS MANUFACTURED BY THE ABOVE NAMED MANUFACTURER AND ARE BEING RESOLD BY THERMACUT. THERMACUT RESERVES THE RIGHT TO SUBSTITUTE OEM PARTS IN PLACE OF THERMACUT PARTS. VALID FROM SEPTEMBER 2024 • PREVIOUS VERSION IS NO LONGER VALID. • © COPYRIGHT 2024 BY THERMACUT® CZECH REPUBLIC. ALL RIGHTS RESERVED.

THERMACUT® REPLACEMENT PARTS SUITABLE FOR MIG GUN PLUGS



THERMACUT®, FHT-EX® AND EX-TRAFIRE® ARE REGISTERED TRADEMARKS OF THERMACUT, K. S. AND MAY BE REGISTERED IN CZECH REPUBLIC AND/OR OTHER COUNTRIES. ALL OTHER TRADEMARKS ARE PROPERTIES OF THEIR RESPECTIVE OWNERS. THERMACUT IS NO WAY AFFILIATED WITH ESAB®, HOBART®, LINCOLN®, TWECO®, MILLER®. MOST THERMACUT PARTS ARE MADE FOR OR BY AN IBG COMPANY. PARTS INDICATED WITH A OEM ARE ORIGINAL PARTS MANUFACTURED BY THE ABOVE NAMED MANUFACTURER AND ARE BEING RESOLD BY THERMACUT. THERMACUT RESERVES THE RIGHT TO SUBSTITUTE OEM PARTS IN PLACE OF THERMACUT PARTS. VALID FROM SEPTEMBER 2024 • PREVIOUS VERSION IS NO LONGER VALID. • © COPYRIGHT 2024 BY THERMACUT® CZECH REPUBLIC. ALL RIGHTS RESERVED.

THERMACUT® REPLACEMENT PARTS SUITABLE FOR MIG GUN TRIGGER CONNECTORS

ESAB® Style

25EAC



8-Pin Male to 4-Pin Female Adapter for ESAB®

LINCOLN® Style

13LAC



8-Pin Male to 4-Pin Female Adapter for Lincoln®

LINCOLN® Style

25LA



Standard on Lincoln® Guns
(Includes Leads with Female Bullet Connectors)

MILLER® Style

25MA



Standard on Miller® and Tweco® Guns
(Includes Leads with Female Bullet Connectors)

LINCOLN® Style

25LAC



Convert Tweco®/Miller® to Lincoln® LN7 Style
Trigger Connector

THERMACUT®, FHT-EX® AND EX-TRAFIRE® ARE REGISTERED TRADEMARKS OF THERMACUT, K. S. AND MAY BE REGISTERED IN CZECH REPUBLIC AND/OR OTHER COUNTRIES. ALL OTHER TRADEMARKS ARE PROPERTIES OF THEIR RESPECTIVE OWNERS. THERMACUT IS NO WAY AFFILIATED WITH ESAB®, HOBART®, LINCOLN®, TWECO®, MILLER®. MOST THERMACUT PARTS ARE MADE FOR OR BY AN IBG COMPANY. PARTS INDICATED WITH A OEM ARE ORIGINAL PARTS MANUFACTURED BY THE ABOVE NAMED MANUFACTURER AND ARE BEING RESOLD BY THERMACUT. THERMACUT RESERVES THE RIGHT TO SUBSTITUTE OEM PARTS IN PLACE OF THERMACUT PARTS. VALID FROM SEPTEMBER 2024 • PREVIOUS VERSION IS NO LONGER VALID. • © COPYRIGHT 2024 BY THERMACUT® CZECH REPUBLIC. ALL RIGHTS RESERVED.

THERMACUT® REPLACEMENT PARTS SUITABLE FOR TIG WELDING

What you need to know about Tungsten...

How Quality Control is addressed with Thermacut Tungsten

“Centerless Ground, Precision Centerless Ground, or Ground”
All the terms mean the same thing As a requirement of the ISO and AWS specifications, good quality tungsten is centerless ground, precision centerless ground or ground. Our electrodes are centerless ground.

“Annealed”
Annealing is analogous to the heating-treating processes whereby the electrodes are heated in an oven to a specified temperature, rate and duration to inspire atomic settling where the grain structure Tungsten becomes more consistent and facilitating electron migration. Our electrodes are annealed.

“100% Eddy Current Tested”
Eddy current testing monitors the electrical field properties surrounding the electrode as current passes through it. This test verifies proper current flow and detects any voids, cracks or other physical imperfections that would impede performance. Since ISO requires a lot control, a failed lot can then be controlled, segregated, re-tested and scrapped if necessary. All our tungsten is eddy current tested.

Sharpening Your Tungsten
A common mistake by most companies is using an contaminated grinding wheel. By not using a dedicated system any impurities left on the grinding wheel from your last use are now imbedded into the tungsten. The end result is a poor weld.

Call today to learn more about our Tungsten Grinder

Pure – color coded Green

Part No.	Description	Std. Pkg
T040-7-PUR	Tungsten, .040x7, GND, PUR	10
T1/16-7-PUR	Tungsten, 1/16x7, GND, PUR	10
T1/4-7-PUR	Tungsten, 1/4x7, GND, PUR	5
T1/8-3-PUR	Tungsten, 1/8x3, GND, PUR	10
T1/8-7-PUR	Tungsten, 1/8x7, GND, PUR	10
T3/32-3-PUR	Tungsten, 3/32x3, GND, PUR	10
T3/32-7-PUR	Tungsten, 3/32x7, GND, PUR	10
T5/32-7-PUR	Tungsten, 5/32x7, GND, PUR	10

E3 Tungsten - The Supreme Tungsten Electrode

Part No.	Description	Std. Pkg
T020-7E3	.20X7 GRND E3 TUNGSTEN	10
T1/16-7E3	1/16X7 GRND E3 TUNGSTEN	5
T3/16-7E3	3/16 GRND E3 TUNGSTEN	10
T3/32-7E3	3/32X7 GRND E3 TUNGSTEN	10
T5/32-7E3	5/32X7 GRND E3 TUNGSTEN	10

1.5% Lanthanum – color coded Gold

Part No.	Description	Std. Pkg
T1/16-7-LAN	Tungsten, 1/16x7, GND 1.5% LA	10
T1/4-7-LAN	Tungsten, 1/4x7, GND 1.5% LA	5
T1/8-7-LAN	Tungsten, 1/8x7, GND 1.5% LA	10
T3/32-7-LAN	Tungsten, 3/32x7, GND 1.5% LA	20

Zirconium – color coded Brown

Part No.	Description	Std. Pkg
T040-7-ZIR	Tungsten, .040x7, GND, ZIR	10
T1/16-7-ZIR	Tungsten, 1/16x7, GND, ZIR	10
T1/8-7-ZIR	Tungsten, 1/8x7, GND, ZIR	10
T3/32-7-ZIR	Tungsten, 3/32x7, GND, ZIR	10
T5/32-7-ZIR	Tungsten, 5/32x7, GND, ZIR	10

2% Cerium – color coded Gray

Part No.	Description	Std. Pkg
T1/16-7-CER	Tungsten, 1/16x7, GND 2% CER	10
T3/32-3-CER	Tungsten, 3/32x3, GND 2% CER	10
T3/32-7-CER	Tungsten, 3/32x7, GND 2% CER	10
T5/32-7-CER	Tungsten, 5/32x7, GND 2% CER	10

THERMACUT®, FHT-EX® AND EX-TRAFIRE® ARE REGISTERED TRADEMARKS OF THERMACUT, K. S. AND MAY BE REGISTERED IN CZECH REPUBLIC AND/OR OTHER COUNTRIES. ALL OTHER TRADEMARKS ARE PROPERTIES OF THEIR RESPECTIVE OWNERS. MOST THERMACUT PARTS ARE MADE FOR OR BY AN IBG COMPANY. VALID FROM SEPTEMBER 2024 • PREVIOUS VERSION IS NO LONGER VALID. • THIS CATALOG IS VALID FOR USA CUSTOMERS ONLY • © COPYRIGHT 2024 BY THERMACUT® CZECH REPUBLIC. ALL RIGHTS RESERVED.

**THERMACUT® REPLACEMENT PARTS SUITABLE FOR
TIG TORCHES 9, 20, 24, 25
125 AMP AIR COOLED MODEL 9**

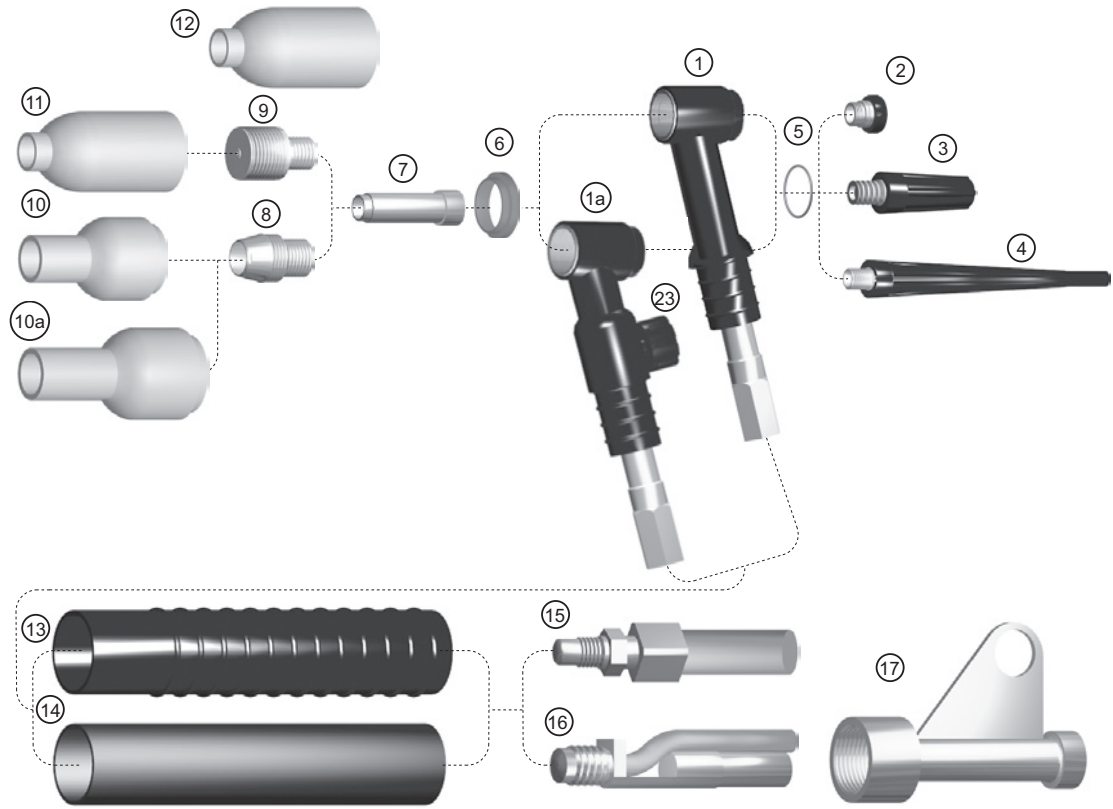

250 AMP WATER COOLED MODEL 20

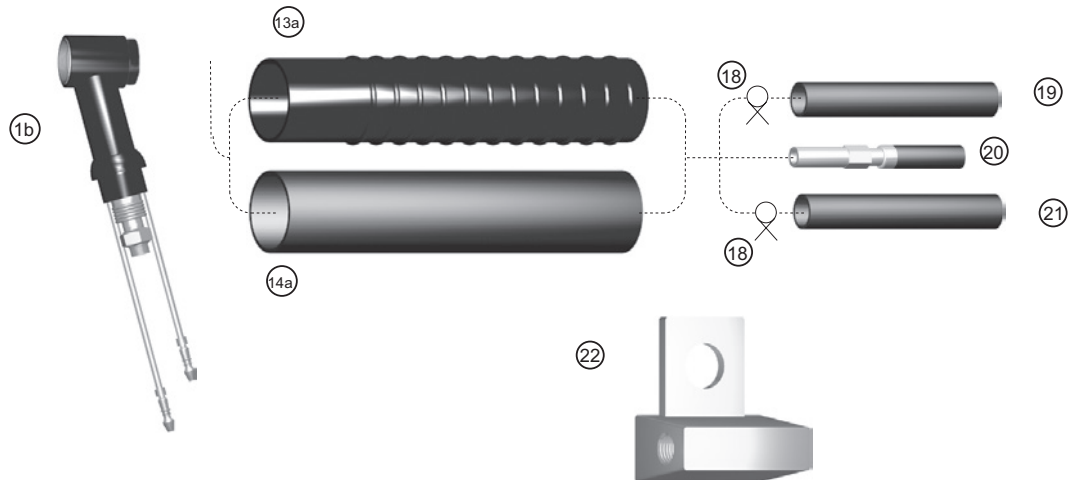

THERMACUT®, FHT-EX® AND EX-TRAFIRE® ARE REGISTERED TRADEMARKS OF THERMACUT, K. S. AND MAY BE REGISTERED IN CZECH REPUBLIC AND/OR OTHER COUNTRIES. ALL OTHER TRADEMARKS ARE PROPERTIES OF THEIR RESPECTIVE OWNERS. MOST THERMACUT PARTS ARE MADE FOR OR BY AN IBG COMPANY. VALID FROM SEPTEMBER 2024 • PREVIOUS VERSION IS NO LONGER VALID. • THIS CATALOG IS VALID FOR USA CUSTOMERS ONLY • © COPYRIGHT 2024 BY THERMACUT® CZECH REPUBLIC. ALL RIGHTS RESERVED.

THERMACUT® REPLACEMENT PARTS SUITABLE FOR TIG TORCHES 9, 20, 24, 25

Item	Part No.	Description	Torch	Std. Pkg.	Item	Part No.	Description	Torch	Std. Pkg.
1.	SR-9-12-2	125A Torch Pkg., 2 pc, 12'	9	1		45V42	Gas Lens .040	9,20	5
	SR-9F-12R	125A Torch Pkg., 12'	9	1		45V43	Gas Lens 1/16	9,20	5
	HP-9-12R	125A Torch Pkg., 12'	9	1		45V44	Gas Lens 3/32	9,20	5
	HP-9-25R	125A Torch Pkg., 25'	9	1		45V45	Gas Lens 1/8	9,20	5
	SR-9	125A Torch Body	9	1	10.	13N08	Alumina Cup #4	9,20	10
	SR-9-12R	125A Torch Pkg., 12'	9	1		13N09	Alumina Cup #5	9,20	10
	SR-12-2	125A Torch Pkg., 2 pc, 12'	9	1		13N10	Alumina cup #6	9,20	10
	SR-9-25R	125A Torch Pkg., 25'	9	1		13N11	Alumina Cup #7	9,20	10
	SR-9F	125A Torch Body, Flexible	9	1		13N12	Alumina Cup #8	9,20	10
	SR-9F-25R	125A Torch Pkg., 25'	9	1		13N13	Alumina Cup #10	9,20	10
1a.	SR-9FV	125A Torch Body, Flex with Valve	9	1	10a.	13N14	Ceramic Cup #4	9,20	10
	SR-9FV-12R	125A Torch Pkg, 12' with Valve	9	1		13N18	Ceramic Cup #8	9,20	10
	SR-9FV-25R	125A Torch Flex 25' with Valve	9	1		53N27	Ceramic Cup #6	24	10
	SR-9V	125A Torch Body, with Valve	9	1	11.	14N65	Alumina Cup #4	9	10
	SR-9V-12-2	125A Torch Pkg., 12' with Valve	9	1		53N58	Alumina Cup #4	9,20,24,25	10
	SR-9V-12R	125A Torch Pkg., 12' with Valve	9	1		53N59	Alumina Cup #5	9,20,24,25	10
	SR-9V-25R	125A Torch Pkg., 25' with Valve	20	1		53N60	Alumina Cup #6	9,20,24,25	10
1b.	HP-20	250A Torch Body	20	1		53N61	Alumina Cup #7	9,20,24,25	10
	HP-20-12	250A Torch Pkg., 12'	20	1		53N61S	Alumina Cup #8	9,20,24,25	10
	HP-20-25	250A Torch Pkg., 25'	20	1	12.	57N75	Alumina Cup #6	9,17,18,20	10
	SR-20	250A Torch Body	20	1		57N74	Alumina Cup #8	9,17,18,20	10
	SR-20-12	250A Torch Pkg., 12'	20	1		53N87	Alumina Cup #12	9,17,18,20	10
	SR-20-12R	250A Torch Pkg., 25'	20	1		53N88	Alumina Cup #10	9,17,18,20	10
	SR-20-25	250A Torch Pkg., 25'	20	1		53N89	Alumina Cup, Short	9,17,18,20	10
	SR-20F-25R	250A Torch Pkg., 25'	20	1	13.	H-100R	Handle Ribbed	SR9,SR17	1
	SR-20-25R	250A Torch Pkg., 25'	24	1	13a.	53N06R	Handle, Ribbed	HP9,HP20	1
	HP-24	80 Amp Air-Cooled Torch	9,20	1	14.	H-100	Handle, Smooth	SR9,SR17	1
2.	41V33	Back Cap, Short	9,20	5	14a.	53N06	Handle, Smooth	HP9,HP20	1
3.	41V35	Back Cap, Medium	9,20	5	15.	57Y01R	Power Cable 12.5'	9V,17,17V	1
4.	41V24	Back Cap, Long	9,20	5		57Y03R	Power Cable 25'	9V,17,17V	1
5.	98W77	O-Ring	9,20	10	16.	57Y01-2	Power Cable 12.5' (2 piece)	9,17	1
6.	598882	Cup Gasket	9,20	1		57Y03-2	Power Cable 25' (2 piece)	9,17	1
7.	13N21	Collet .040	9,20	5	17.	105Z57	Power Cable Adapter	9,17	10
	13N22	Collet 1/16	9,20	5	18.	53N04	Hose Clamp	24	10
	12N23	Collet 3/32	9,20	5	19.	45V09	Gas Hose 12.5'	20,24W,25	1
	13N24	Collet 1/8	24	5		45V10	Gas Hose 25'	20,24W,25	1
	53N14	Collet 1/16	24	5		40V77	Gas Hose 12.5' Extension	18,20,25	1
	53N16	Collet .040	9	5		40V77L	Extension, 25' Gas Hose	18,20,25	1
8.	13N26	Collet Body .040	9,20	5		40V77LR	Argon Hose Extension 25'	18,20,25	1
	13N27	Collet Body 1/16	24	5	20.	45V03	Power Cable 12.5'	20,24W,25	1
	13N28	Collet Body 3/32	9,20	5		45V04	Power Cable 25'	20,24W,25	1
	24CB3/32	Collet Body 3/32	24	5		40V78L	Extended Power Cable 25'	18,20,25	1
	13N29	Collet Body 1/8	24	5	21.	45V07	Water Hose 12.5'	20,24W,25	1
9.	45V41	Gas Lens .020	9,20	5		45V08	Water Hose 25'	20,24W,25	1
						40V76	Water Hose Extension 12.5'	18,20,25	1
					22.	45V11	Power Cable Adapter	18,20,24W	1
					23.	VS-2	Valve Knob & Stem	9V,17V	5
					NS	53N66	Gas Lens Insulator	24	5

THERMACUT®, FHT-EX® AND EX-TRAFIRE® ARE REGISTERED TRADEMARKS OF THERMACUT, K. S. AND MAY BE REGISTERED IN CZECH REPUBLIC AND/OR OTHER COUNTRIES. ALL OTHER TRADEMARKS ARE PROPERTIES OF THEIR RESPECTIVE OWNERS. MOST THERMACUT PARTS ARE MADE FOR OR BY AN IBG COMPANY. VALID FROM SEPTEMBER 2024 • PREVIOUS VERSION IS NO LONGER VALID. • THIS CATALOG IS VALID FOR USA CUSTOMERS ONLY • © COPYRIGHT 2024 BY THERMACUT® CZECH REPUBLIC. ALL RIGHTS RESERVED.

**THERMACUT® REPLACEMENT PARTS SUITABLE FOR
TIG TORCHES 17, 18, 26
150 AMP AIR COOLED MODEL 17, 200 AMP AIR COOLED MODEL 26**

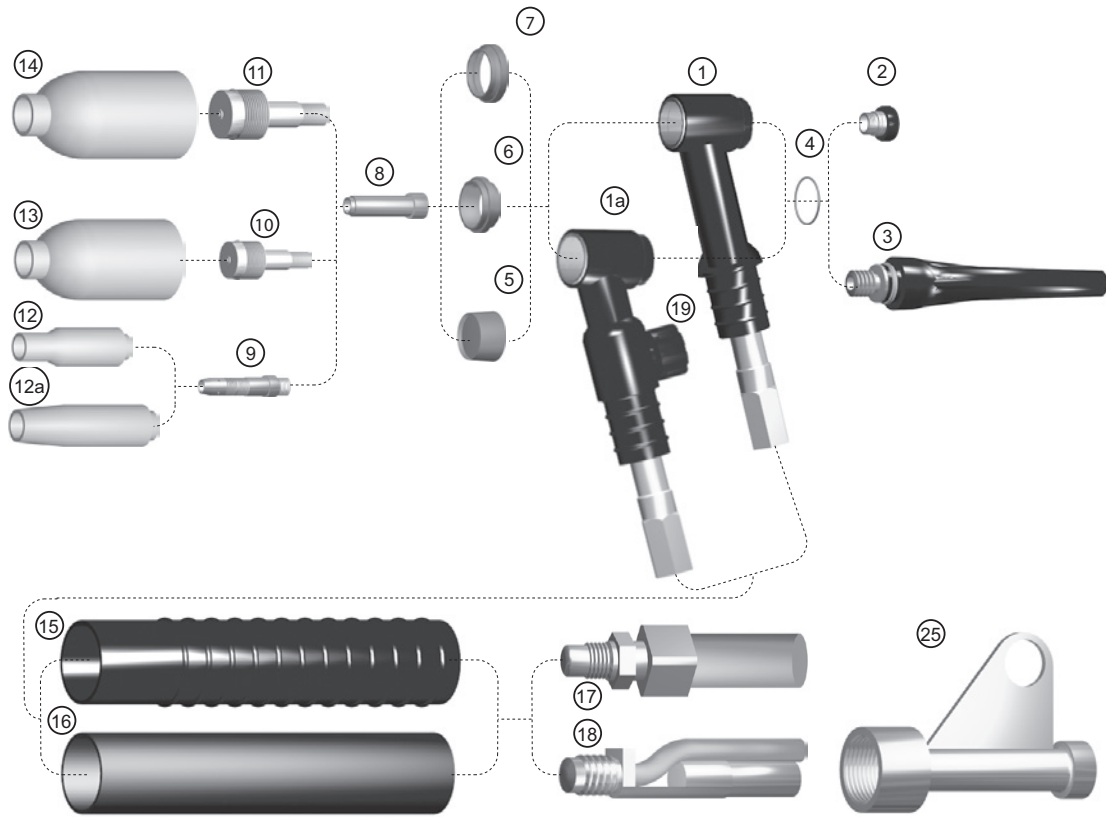

250 AMP WATER COOLED MODEL 20

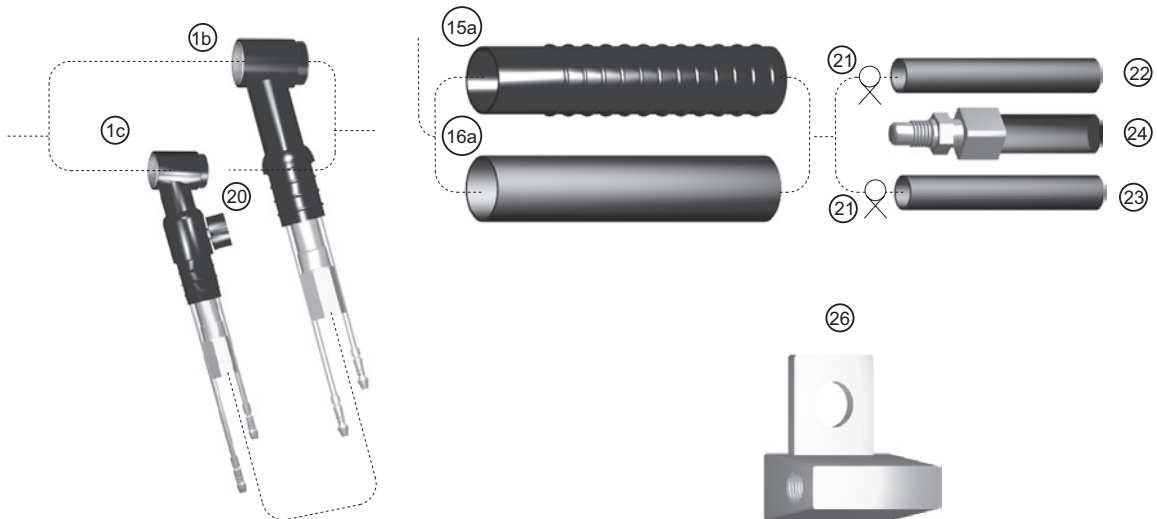

THERMACUT®, FHT-EX® AND EX-TRAFIRE® ARE REGISTERED TRADEMARKS OF THERMACUT, K. S. AND MAY BE REGISTERED IN CZECH REPUBLIC AND/OR OTHER COUNTRIES. ALL OTHER TRADEMARKS ARE PROPERTIES OF THEIR RESPECTIVE OWNERS. MOST THERMACUT PARTS ARE MADE FOR OR BY AN IBG COMPANY. VALID FROM SEPTEMBER 2024 • PREVIOUS VERSION IS NO LONGER VALID. • THIS CATALOG IS VALID FOR USA CUSTOMERS ONLY • © COPYRIGHT 2024 BY THERMACUT® CZECH REPUBLIC. ALL RIGHTS RESERVED.

THERMACUT® REPLACEMENT PARTS SUITABLE FOR TIG TORCHES 17, 18, 26

Item	Part No.	Description	Torch	Std. Pkg	Item	Part No.	Description	Torch	Std. Pkg.
1.	HP-17-12R	150A Torch Pkg., 12'	17	1		SR-18V-12	350A Torch Pkg, with Valve, 12'	18	1
	HP-17-25R	150A Torch Pkg., 25'	17	1		SR-18V-25	350A Torch Pkg, with Valve, 25'	18	1
	SR-17	150A Torch Body	17	1		SR-18-25R	350A Torch Pkg. 25'	18	1
	SR-17-12R	150A Torch Pkg., 12'	17	1		SR-18F-25R	350A W/Cooled Flex Torch 25'	18	1
	SR-17-25-2	150A Torch Pkg, 25' 2pc Hose	17	1	2-3.		Back Caps	17,18,26	5
	SR-17-25R	150A Torch Pkg., 25'	17	1	4.		O-Ring	17,18,26	10
	SR-17F	150A Flexible Torch Body	17	1	5.		Cup Gasket	17,18,26	5
	SR-17F-12R	150 A Torch Pkg. 12' Flex	17	1	6-7.		Gas Lens Insulators	17,18,26	5
	SR-17F-25R	150A Torch Pkg. 25' Flex	17	1	8.		Collets	17,18,26	5
	HP-26	200A Torch Body	26	1	9.		Collet Bodies	17,18,26	5
	HP-26V	200A Torch Body, with Valve	26	1	10-11.		Gas Lenses	17,18,26	5
	SR-26	200A Torch Body	26	1	12-14.		Alumina & Ceramic Cups	17,18,26	5
	SR-26-12R	200A Torch Pkg., 12'	26	1	15.	H-100R	Handle, Ribbed	SR9,SR17	1
	SR-26-25-2	200A Torch Pkg, 25' 2pc Hose	26	1		105Z55R	Handle, Ribbed	HP17	1
	SR-26-25R	200A Torch Pkg., 25'	26	1	15a.	H-200R	Handle, Ribbed	SR18,SR26	1
	SR-26F-25R	200A Torch Pkg. 25' Flex	26	1		10N15R	Handle, Ribbed	SR18,SR26	1
	SR-26F	200A Flexible Torch Body	26	1	16.	H-100	Handle, Smooth	SR9,SR17	1
1a.	HP-17V	150A Torch body with Valve	17	1		105Z55	Handle, Smooth	HP17	1
	HP-17V-12R	150A Torch Pkg, 12' with Valve	17	1	16a.	10N15	Handle, Smooth	SR18,SR26	1
	HP-17V-25R	150A Torch Pkg, 25' with Valve	17	1		54N84R	Handle, Ribbed	HP26	1
	SR-17FV-12-2	150A Torch Pkg, 12' 2pc Hose/Valve	17	1	17.	57Y01R	Power Cable, 12.5'	9V,17,17V	1
	SR-17FV-12R	150A Torch Pkg, 12', with Valve	17	1		57Y03R	Power Cable, 25'	9V,17,17V	1
	SR-17FV-25-2	150A Torch Pkg, 25', 2pc Hose/Valve	17	1	18.	57Y01-2	Power Cable, 12.5' (2 pc)	9,17	1
	SR-17FV	150A Torch Body Flex with Valve	17	1		57Y03-2	Power Cable, 25' (2 pc)	9,17	5
	SR-17FV-25R	150A Torch Flex, 25' with Valve	17	1	19.	VS-2	Valve Knob & Stem	9V,17V	5
	SR-17V	150A Torch Body with Valve	17	1	20.	VS-1	Valve Knob & Stem	26V	10
	SR-17V-12-2	150A Torch Pkg, 12'	17	1	21.	53N04	Hose Clamp	24	1
	SR-17V-12R	150A Torch Pkg, 12' with Valve	17	1	22.	40V74	Water Hose, 12.5'	18	1
	SR-17V-25-2	150A Torch Pkg, 25' 2 pc Hose	17	1		40V76	Water Hose Ext., 12.5'	18,20,25	1
	SR-17V-25R	150A Torch Pkg, 25' with Valve	17	1		41V32	Water Hose, 25'	18	1
	SR-26V	200A Torch Body with Valve	26	1	23.	41V30	Gas Hose, 25'	18	1
	SR-26V-12R	200A Torch Pkg, 12' with Valve	26	1		41V30R	Gas Hose, 25' Rubber	18	1
	SR-26V-12-2	200A Torch Pkg., with Valve	26	1		40V75R	Gas Hose 12.5' Rubber	18	1
	SR-26-12-2	200A Torch Pkg., 20c Cable	26	1		45V10R	Gas Hose 25', Rubber	17	1
	SR-26V-25R	200A Torch Pkg, 25' with Valve	26	1	24.	46V30-2	Pwr Cable&Gas Hose (2pc)	26	1
	SR-26FV	200A Torch Body, Flex with Valve	26	1		40V64	Power Cable 12.5'	18	1
	SR-26FV-25R	200A Torch Pkg, 25' with Valve	26	1		41V29	Power Cable 25'	18	1
	SR-26FV-25-2	200A Torch Pkg., 25', with Valve	26	1		41V29R	Power Cable 25'	18	1
1b.	HP-18-12	350A Torch Pkg, 12'	18	1		46V28R	Power Cable, 12.5'	26	1
	HP-18-25	350A Torch Pkg, 25'	18	1		46V30R	Power Cable, 25'	26	1
	HP-18	350A Torch Body	18	1	25.	45V62	Power Cable Adapter	26	1
	SR-18	350A Torch Body	18	1		45V11	Power Cable Adapter	18,20,24W	1
	SR-18-12	350A Torch Pkg, 12'	18	1	NS	18CG20	Stubby Cup Gasket	17,18,26	5
	SR-18-25	350A Torch Pkg, 25'	18	1	NS	18-7	Insert	17,18,26	5
1c.	SR-18V	350A Torch Body with Valve	18	1					

THERMACUT®, FHT-EX® AND EX-TRAFIRE® ARE REGISTERED TRADEMARKS OF THERMACUT, K. S. AND MAY BE REGISTERED IN CZECH REPUBLIC AND/OR OTHER COUNTRIES. ALL OTHER TRADEMARKS ARE PROPERTIES OF THEIR RESPECTIVE OWNERS. MOST THERMACUT PARTS ARE MADE FOR OR BY AN IBG COMPANY. VALID FROM SEPTEMBER 2024 • PREVIOUS VERSION IS NO LONGER VALID. • THIS CATALOG IS VALID FOR USA CUSTOMERS ONLY • © COPYRIGHT 2024 BY THERMACUT® CZECH REPUBLIC. ALL RIGHTS RESERVED.

THERMACUT® REPLACEMENT PARTS SUITABLE FOR TIG TORCHES

BACK CAPS

Part No.	Description	Torches
57Y02	Long Back Cap	17,18,26
57Y04	Short Back Cup	17,18,26

Part No.	Description	Torches
41V33	Short Back Cup	9,20
41V35	Medium Back Cup	9,20
41V24	Long Back Cap	9,20

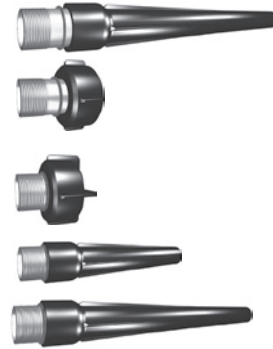

INSULATORS

Part No.	Description	Torches
54N01	Gas Lens Insulator	17,18,26

Part No.	Description	Torches
54N63	Large Diameter Gas Lens Insulator	17,19,26

Part No.	Description	Torches
598882	Cup Gasket	9,20,25

Part No.	Description	Torches
18CG	Cup Gasket	17,18,26

Part No.	Description	Torches
18-7	Insert	17,18,26



CABLE COVERS

Part No.	Description	Std. Pkg.
310	Zytol cable cover, 3 × 10'	1
310V	Vytol cable cover, 3 × 10'	1
323	Zytol cable cover, 3 × 23'	1
323V	Vytol cable cover, 3 × 23'	1
410	Zytol cable cover, 4 × 10'	1
420	Zytol cable cover, 4 × 20'	1



THERMACUT®, FHT-EX® AND EX-TRAFIRE® ARE REGISTERED TRADEMARKS OF THERMACUT, K. S. AND MAY BE REGISTERED IN CZECH REPUBLIC AND/OR OTHER COUNTRIES. ALL OTHER TRADEMARKS ARE PROPERTIES OF THEIR RESPECTIVE OWNERS. MOST THERMACUT PARTS ARE MADE FOR OR BY AN IBG COMPANY. VALID FROM SEPTEMBER 2024 • PREVIOUS VERSION IS NO LONGER VALID. • THIS CATALOG IS VALID FOR USA CUSTOMERS ONLY • © COPYRIGHT 2024 BY THERMACUT® CZECH REPUBLIC. ALL RIGHTS RESERVED.

THERMACUT® REPLACEMENT PARTS SUITABLE FOR TIG TORCHES

COLLETS

Qty per pkg: 5

Size	Part No.	Torch
.020	10N21	17,18,26
.040	10N22	17,18,26
1/16	10N23	17,18,26
3/32	10N24	17,18,26
1/8	10N25	17,18,26
5/32	54N20	17,18,26

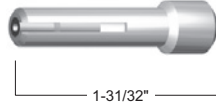

Size	Part No.	Torch
3/32	10N24S	17,18,26
1/8	10N25S	17,18,26

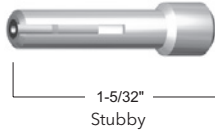

Size	Part No.	Torch
.040	13N21	9,20,25
1/16	13N22	9,20,25
3/32	13N23	9,20,25
1/8	13N24	9,20,25

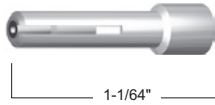

Size	Part No.	Torch
.040	53N16	24,24W
1/16	53N14	24,24W
3/32	24C332	24,24W

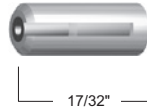

Size	Part No.	Torch
1/16	53N64	24,24W



POWER CABLE ADAPTERS

Qty per pkg: 5

Part No.	Torch
45V11	18,20



Part No.	Torch
105Z57	17/9



COLLET BODIES

Qty per pkg: 5

Size	Part No.	Torch
.020	10N29	17,18,26
.040	10N30	17,18,26
1/16	10N31	17,18,26
3/32	10N32	17,18,26
1/8	10N28	17,18,26
5/32	406488	17,18,26

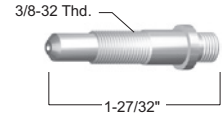

Size	Part No.	Torch
.020	13N25	9,20,25
.040	13N26	9,20,25
1/16	13N27	9,20,25
3/32	13N28	9,20,25
1/8	13N29	9,20,25

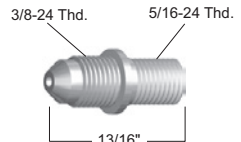

Size	Part No.	Torch
1/16	53N19	24,24W
3/32	24CB332	24,24W

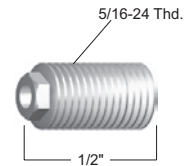

GAS LENSES

Qty per pkg: 5

Size	Part No.	Torch
.020	45V29	17,18,26
1/16	45V25	17,18,26
3/32	45V26	17,18,26
1/8	45V27	17,18,26
5/32	45V28	17,18,26

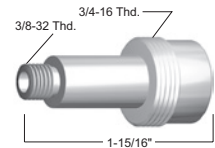

Size	Part No.	Torch
3/32	45V64	17,18,26
1/8	995795	17,18,26

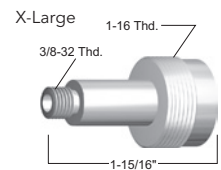

Size	Part No.	Torch
.040	45V42	9,20,24,25
1/16	45V43	9,20,24,25
3/32	45V44	9,20,24,25
1/8	45V45	9,20,24,25

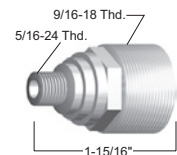

THERMACUT®, FHT-EX® AND EX-TRAFIRE® ARE REGISTERED TRADEMARKS OF THERMACUT, K. S. AND MAY BE REGISTERED IN CZECH REPUBLIC AND/OR OTHER COUNTRIES. ALL OTHER TRADEMARKS ARE PROPERTIES OF THEIR RESPECTIVE OWNERS. MOST THERMACUT PARTS ARE MADE FOR OR BY AN IBG COMPANY. VALID FROM SEPTEMBER 2024 • PREVIOUS VERSION IS NO LONGER VALID. • THIS CATALOG IS VALID FOR USA CUSTOMERS ONLY • © COPYRIGHT 2024 BY THERMACUT® CZECH REPUBLIC. ALL RIGHTS RESERVED.

**THERMACUT® REPLACEMENT PARTS SUITABLE FOR
TIG TORCHES
ALUMINA CUPS Qty per package: 10**

Part No.	I.D.	Size	Torches
10N50	1/4"	4	17,18,26
10N49	5/16"	5	17,18,26
10N48	3/8"	6	17,18,26
10N47	7/16"	7	17,18,26
10N46	1/2"	8	17,18,26
10N45	5/8"	10	17,18,26
10N44	3/4"	12	17,18,26

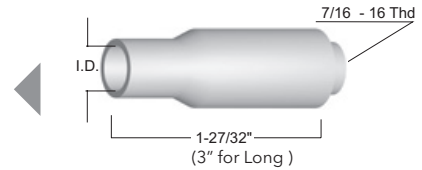

54N18	1/4"	4	17,18,26
54N17	5/16"	5	17,18,26
54N16	3/8"	6	17,18,26
54N15	7/16"	7	17,18,26
54N14	1/2"	8	17,18,26

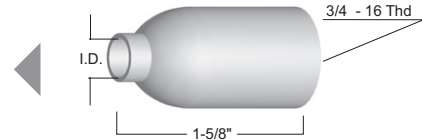

13N08	1/4"	4	9, 20, 25
13N09	5/16"	5	9, 20, 25
13N10	3/8"	6	9, 20, 25
13N11	7/16"	7	9, 20, 25
13N12	1/2"	8	9, 20, 25
13N13	5/8"	10	9, 20, 25

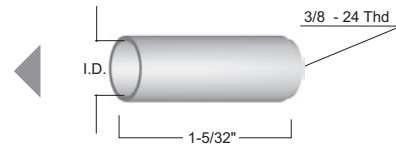

53N58	1/4"	4	9, 20, 24
53N59	5/16"	5	9, 20, 24
53N60	3/8"	6	9, 20, 24
53N61	7/16"	7	9, 20, 24

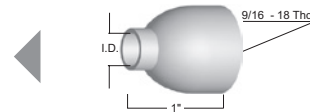

57N75	3/8"	6	17, 18, 26
57N74	1/2"	8	17, 18, 26
53N88	5/8"	10	17, 18, 26
53N87	3/4"	12	17, 18, 26
53N89	15/16"	Short	17, 18, 26

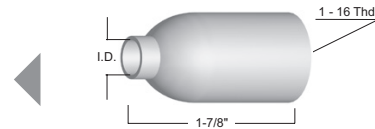

105Z42	5/16"	5	17, 18, 26
105Z43	1/4"	4	17, 18, 26
105Z44	3/8"	6	17, 18, 26
105Z45	7/16"	7	17, 18, 26
08N78	1/2"	8	17, 18, 26
08N79	5/8"	10	17, 18, 26
08N80	3/4"	12	17, 18, 26

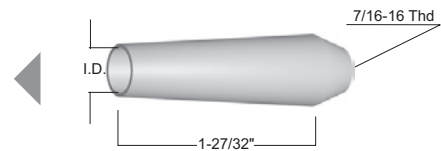

13N14	1/4"	4	9, 20, 25
13N15	5/16"	5	9, 20, 25
13N16	3/8"	6	9, 20, 25
13N17	7/16"	7	9, 20, 25
13N17	1/2"	8	9, 20, 25
13N19	5/8"	10	9, 20, 25

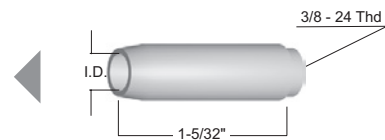

THERMACUT®, FHT-EX® AND EX-TRAFIRE® ARE REGISTERED TRADEMARKS OF THERMACUT, K. S. AND MAY BE REGISTERED IN CZECH REPUBLIC AND/OR OTHER COUNTRIES. ALL OTHER TRADEMARKS ARE PROPERTIES OF THEIR RESPECTIVE OWNERS. MOST THERMACUT PARTS ARE MADE FOR OR BY AN IBG COMPANY. VALID FROM SEPTEMBER 2024 • PREVIOUS VERSION IS NO LONGER VALID. • THIS CATALOG IS VALID FOR USA CUSTOMERS ONLY • © COPYRIGHT 2024 BY THERMACUT® CZECH REPUBLIC. ALL RIGHTS RESERVED.



WWW.THERMACUT.COM

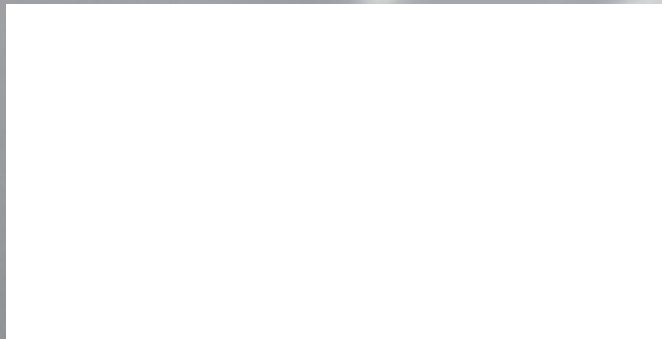

THERMACUT[®]
THE CUTTING COMPANY[®]